

University of Nevada, Las Vegas  
Computer Science 456/656 Fall 2010

The entire examination is 1070 points.

Name: \_\_\_\_\_

No books, notes, scratch paper, or calculators. Use pen or pencil, any color. Use the rest of this page and the backs of the pages for scratch paper. If you need more scratch paper, it will be provided.

1. [5 points each] True or False. If the question is currently open, write “O” or “Open.”
  - (a) \_\_\_\_\_ Every subset of a regular language is regular.
  - (b) \_\_\_\_\_ The intersection of any context-free language with any context-free language is context-free.
  - (c) \_\_\_\_\_ The complement of every recursive language is recursive.
  - (d) \_\_\_\_\_ The complement of every recursively enumerable language is recursively enumerable.
  - (e) \_\_\_\_\_ Every language which is generated by an unrestricted grammar is recursively enumerable.
  - (f) \_\_\_\_\_ The question of whether two context-free grammars generate the same language is undecidable.
  - (g) \_\_\_\_\_ There exists some proposition which is true but which has no proof.
  - (h) \_\_\_\_\_ The set of all binary numerals for prime numbers is in the class  $\mathcal{P}$ .
  - (i) \_\_\_\_\_ If  $L_1$  reduces to  $L_2$  in polynomial time, and if  $L_2$  is  $\mathcal{NP}$ , and if  $L_1$  is  $\mathcal{NP}$ -complete, then  $L_2$  must be  $\mathcal{NP}$ -complete.
  - (j) \_\_\_\_\_ Given any context-free grammar  $G$  and any string  $w \in L(G)$ , there is always a unique leftmost derivation of  $w$  using  $G$ .
  - (k) \_\_\_\_\_ For any deterministic finite automaton, there is always a unique minimal non-deterministic finite automaton equivalent to it.
  - (l) \_\_\_\_\_ Using multi-processors and other advanced technology, it is possible to design a machine which decides the halting problem.
  - (m) \_\_\_\_\_ The question of whether two regular expressions are equivalent is decidable.
  - (n) \_\_\_\_\_ The intersection of any context-free language with any regular language is context-free.
  - (o) \_\_\_\_\_ Let  $L = \{\langle M \rangle \mid M \text{ halts with no input}\}$ . Then  $L$  is recursively enumerable.
  - (p) \_\_\_\_\_ The complement of every context-free language is context-free.

- (q) \_\_\_\_\_ No language which has an ambiguous context-free grammar can be accepted by a DPDA.
- (r) \_\_\_\_\_ The union of any two context-free languages is context-free.
- (s) \_\_\_\_\_ The question of whether a given Turing Machine halts with empty input is decidable.
- (t) \_\_\_\_\_ The class of languages accepted by non-deterministic finite automata is the same as the class of languages accepted by deterministic finite automata.
- (u) \_\_\_\_\_ The intersection of any two regular languages is regular.
- (v) \_\_\_\_\_ The intersection of any two context-free languages is context-free.
- (w) \_\_\_\_\_ If  $L_1$  reduces to  $L_2$  in polynomial time, and if  $L_2$  is  $\mathcal{NP}$ , then  $L_1$  must be  $\mathcal{NP}$ .
- (x) \_\_\_\_\_ Let  $F(0) = 1$ , and let  $F(n) = 2^{F(n-1)}$  for  $n > 0$ . Then  $F$  is Turing-computable.
- (y) \_\_\_\_\_ Every language which is accepted by some non-deterministic machine is accepted by some deterministic machine.
- (a) \_\_\_\_\_ The language of all regular expressions over the binary alphabet is a regular language.
- (b) \_\_\_\_\_ Let  $\pi$  be the ratio of the circumference of a circle to its diameter. (That's the usual meaning of  $\pi$  you learned in second grade.) The problem of whether the  $n^{\text{th}}$  digit of  $\pi$ , for a given  $n$ , is equal to a given digit is decidable.
- (c) \_\_\_\_\_ There cannot exist any computer program that can decide whether any two C++ programs are equivalent.
- (d) \_\_\_\_\_ An undecidable language is necessarily  $\mathcal{NP}$ -complete.
- (e) \_\_\_\_\_ Every context-free language is in the class  $\mathcal{P}$ -TIME.
- (f) \_\_\_\_\_ Every function that can be mathematically defined is Turing computable.
- (g) \_\_\_\_\_ The language of all binary strings which are the binary numerals for multiples of 23 is regular.
- (h) \_\_\_\_\_ The language of all binary strings which are the binary numerals for prime numbers is context-free.
- (i) \_\_\_\_\_ Every bounded function from integers to integers is Turing-computable. (We say that  $f$  is *bounded* if there is some  $B$  such that  $|f(n)| \leq B$  for all  $n$ .)
- (j) \_\_\_\_\_ The language of all palindromes over  $\{0, 1\}$  is inherently ambiguous.
- (k) \_\_\_\_\_ Every context-free grammar can be parsed by some deterministic top-down parser.
- (l) \_\_\_\_\_ Every context-free grammar can be parsed by some non-deterministic top-down parser.
- (m) \_\_\_\_\_ Every context-free grammar can be parsed by some deterministic bottom-up parser.
- (n) \_\_\_\_\_ Every context-free grammar can be parsed by some non-deterministic bottom-up parser.
- (o) \_\_\_\_\_ Commercially available parsers cannot use the LALR technique, since most modern programming languages are not context-free.

- (p) \_\_\_\_\_ The boolean satisfiability problem is undecidable.
- (q) \_\_\_\_\_ There is a parallel processor machine which can solve the boolean circuit problem in poly-logarithmic time.
- (r) \_\_\_\_\_ The set of all binary numerals for prime numbers is in the class  $\mathcal{P}$ -TIME.
- (s) \_\_\_\_\_ If RSA coding is insecure, then  $\mathcal{P} = \mathcal{NP}$ .
2. [5 points] Every context-free language is accepted by some \_\_\_\_\_.
3. [10 points] If there is an easy reduction from  $L_1$  to  $L_2$ , then \_\_\_\_\_ is at least as hard as \_\_\_\_\_.
4. [5 points each] For each language given, write “R” if the language is recursive, write “RE not R” if the language is recursively enumerable but not recursive, and write “not RE” if the language is not recursively enumerable.
- (a) \_\_\_\_\_ The language consisting of all Pascal programs  $p$  such that  $p$  halts if given  $p$  as its input file.
- (b) \_\_\_\_\_ The language of all encodings of Turing Machines which fail to halt for at least one possible input string.
- (c) \_\_\_\_\_ The 0-1 Traveling Salesman Problem.
- (d) \_\_\_\_\_ The diagonal language.
- (e) \_\_\_\_\_ The universal language.
- (f) \_\_\_\_\_  $L_{\text{sat}}$ , the set of satisfiable boolean expressions.
5. [5 points each] For each question, give one example of a language, either by using the standard name of the language, or describing it in very few words. No proofs are required.
- (a) Give an example of an infinite language that is regular.
- (b) Give an example of a context-free language that is not regular.
- (c) Give an example of a language in the class  $\mathcal{P}$  that is not context-free.
- (d) Give an example of a recursive language that is  $\mathcal{NP}$ -complete.
- (e) Give an example of a recursively enumerable language that is not recursive.
- (f) Give an example of a language that is not recursively enumerable.
6. [15 points] Draw the state diagram for a minimal DFA that accepts the language described by the regular expression  $(a+b)^*ab$

7. [15 points] Write a regular expression for the language accepted by the NFA shown in Figure 1.
8. [20 points] Let  $L$  be the language of all binary numerals for positive integers equivalent to 2 modulo 3. Thus, for example, the binary numerals for 2, 5, 8, 11, 14, 17 ... are in  $L$ . We allow a binary numeral to have leading zeros; thus (for example)  $001110 \in L$ , since it is a binary numeral for 14. Draw a minimal DFA which accepts  $L$ .
9. Consider the context-free grammar  $G_1$  with start symbol  $S$  and productions as follows:
- $$S \rightarrow SS$$
- $$S \rightarrow aSb$$
- $$S \rightarrow \epsilon$$
- (a) [10 points] Show that  $G_1$  is ambiguous.
- (b) [10 points] Find an unambiguous context-free grammar  $G_2$  that is equivalent to  $G_1$ .
10. [10 points] Consider the context-free grammar with start symbol  $S$  and productions as follows:
- $$S \rightarrow s$$
- $$S \rightarrow bLn$$
- $$S \rightarrow wS$$
- $$L \rightarrow \epsilon$$
- $$L \rightarrow SL$$
- Write a leftmost derivation of the string  $bswsbwsnn$
11. [5 points] What class of machines accepts the class of context free languages?
12. [5 points] What class of machines accepts the class of regular languages?
13. [5 points] What class of machines accepts the class of recursively enumerable languages?
14. [10 points] What is the Church-Turing Thesis, and why is it important?
15. [10 points] What does it mean to say that a language can be generated in *canonical order*? What is the class of languages that can be so generated?
16. [5 points] What does it mean to say that machines  $M_1$  and  $M_2$  are *equivalent*?
17. [10 points each] Give definitions for each of the following. Assume that you are writing the definitions for a top mathematics graduate student who has never taken a course in automata theory, but who did sit in a lecture once where “alphabet,” “string,” and “language” were defined. The student also once read an article in which Turing machines were defined.
- (a) Give a definition of the language class  $\mathcal{NP}$ -TIME.
- (b) Give a definition of  $\mathcal{NP}$ -complete language.
- (c) What does it mean to say that a language  $L$  is *decidable*?

- (d) Give the definition of a *polynomial time reduction* of a language  $L_1$  to another language  $L_2$ .
18. [15 points] Let  $\Sigma = \{0,1\}$ , the binary alphabet. We say a string  $w$  over  $\Sigma$  is *mostly positive* if  $w$  has more 1's than 0's. Let  $L$  be the set of mostly positive strings over  $\Sigma$ .  
Give a context-free grammar for  $L$ .
19. [30 points] Let  $\Sigma = \{0,1\}$ , the binary alphabet. Let  $L$  be the set of all strings  $w$  over  $\Sigma$  of the form  $1^n 0^n 1^n$ , where  $n \geq 0$ . Use the pumping lemma to prove that  $L$  is not a context-free language.
20. [10 points] Draw a minimal DFA which accepts the language  $L$  over the binary alphabet  $\Sigma = \{0,1\}$  consisting of all strings in which every '001' is followed by '1'.
21. [20 points] Construct a minimal DFA equivalent equivalent to the NFA shown in Figure 1.

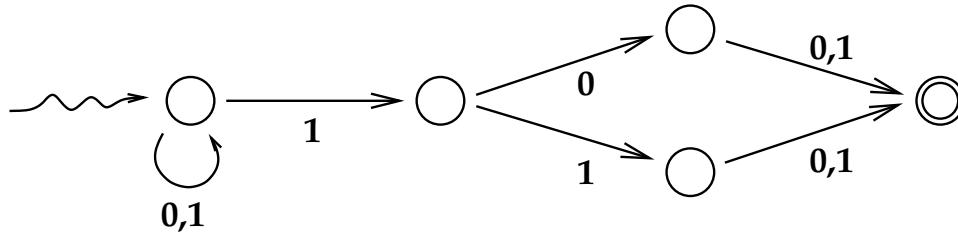

Figure 1: The NFA for Problems 7 and 21.

22. [10 points] Consider the context-free grammar  $G$ , with start symbol  $S$  and productions as follows:  
 $S \rightarrow s$   
 $S \rightarrow bLn$   
 $S \rightarrow iS$   
 $S \rightarrow iSeS$   
 $L \rightarrow \epsilon$   
 $L \rightarrow LS$   
 Prove that  $G$  is ambiguous by giving two different leftmost derivations for some string.
23. [10 points] What does it mean to say that a language  $L_1$  reduces to a language  $L_2$  in polynomial time?
24. [10 points] What does it mean to say that a language  $L$  is decidable?
25. [30 points] Let  $\Sigma = \{0,1\}$ , the binary alphabet. Let  $L \subseteq \Sigma^*$  be recursively enumerable, but not recursive, and let  $M$  be a Turing machine that accepts  $L$ . If  $w \in L$ , let  $T_M(w)$  be the number of steps of  $M$  in the valid computation with input  $w$ . For any string  $w \in \Sigma^*$ , define

$$f(w) = \begin{cases} T_M(w) & \text{if } w \in L \\ 0 & \text{if } w \notin L \end{cases}$$

Prove that  $f$  is not recursive.

26. [5 points each] Classify each of the following problems or languages as just one of the following three: Known to be polynomial, known to be NP but not whether NP-complete, or known to be NP-complete.

- (a) \_\_\_\_\_ Boolean satisfiability.
- (b) \_\_\_\_\_ The 0-1 traveling salesman problem.
- (c) \_\_\_\_\_ The knapsack problem where, for each instance, the size of each item is a positive integer that does not exceed the square of the number of items, and all the numbers are written in binary notation.
- (d) \_\_\_\_\_ The clique problem.
- (e) \_\_\_\_\_ The language generated by a given context-free grammar.
- (f) \_\_\_\_\_ The set of all pairs of integers  $(n, m)$  such that  $n$  has a divisor which is at least  $m$ . (The input for an instance of this problem is the string consisting of the binary numeral for  $n$ , followed by a comma, followed by the binary numeral for  $m$ .)

27. [30 points] Consider the context-free grammar, and the GOTO/ACTION table for an LALR parser for that grammar, given below. (Note that the grammar is ambiguous.) Show the sequence of configurations of the parser, the output sequence, and the parse tree determined by the parser, for each of the given input strings.

GRAMMAR	ACTION-GOTO TABLES							INPUT STRINGS	
	x	y	-	/	(	)	eof	S	
	0.	s9	s10			s3		4	
	1.	s9	s10			s3		5	(a) x-y-x
	2.	s9	s10			s3		6	(b) x-(y-x)
1. $S \rightarrow S-S$	3.	s9	s10			s3		7	
2. $S \rightarrow S/S$	4.			s1	s2		halt		(c) x/y-x
3. $S \rightarrow (S)$	5.			r1	s2		r1	r1	(d) x/(y-x)
4. $S \rightarrow x$	6.			r2	r2		r2	r2	
5. $S \rightarrow y$	7.			s1	s2		s8		(e) (x-y)/x
	8.			r3	r3		r3	r3	(f) x-y/x
	9.			r4	r4		r4	r4	
	10.			r5	r5		r5	r5	

28. [30 points] Consider the grammar given below. Design an LALR parser for that grammar. For your convenience, stack states are given on the right hand side of the production.

- (a)  $S \rightarrow \epsilon$
- (b)  $S \rightarrow a_2 S_3 b_4 S_5$

29. [5 points each] For each language given, write “REG” if the language is regular, write “CF not “REG” if the language is context-free but not regular, write “R not CF” if the language is recursive but not context-free, write “RE not R” if the language is recursively enumerable but not recursive, and write “not RE” if the language is not recursively enumerable.

- (a) \_\_\_\_\_ The set of all strings over the alphabet  $\{a, b, c\}$  where are **not** of the form  $a^n b^n c^n$ .
- (b) \_\_\_\_\_ The language of all encodings of Turing Machines which halt for at least one possible input string.

- (c) \_\_\_\_\_ The 0-1 Traveling Salesman Problem.
- (d) \_\_\_\_\_ The diagonal language.
30. [15 points] Draw a minimal DFA which accepts the language  $L$  over the binary alphabet  $\Sigma = \{a, b, c\}$  consisting of all strings which contain either  $aba$  or  $caa$  as a substring.
31. [30 points] Consider the language  $L$  of all strings which would be acceptable as algebraic expressions involving variables and constants, where:
- Every variable name is either  $x$ ,  $y$ , or  $z$ .
  - Every constant is a natural number between 0 and 9
  - The only operators are addition, subtraction, and multiplication.
  - The symbol ‘ $-$ ’ is used only for subtraction. There is no negation.
  - There is no multiplication symbol. Multiplication is indicated by concatenating strings.
  - In multiplication of a constant by anything else, the constant must come first, and there can be at most one constant factor in any term.
  - Parentheses can be used.

Here are some strings in the language  $x(y + 2z)$ ,  $x - 1 - z$ ,  $4(zx - 2y)(x + z(x - 1))$ .

Give a grammar for  $L$  which is consistent with the usual semantics (as you learned in school) of such expressions.

32. [15 points] Draw a minimal DFA which accepts the language of all strings over  $\{a, b, c\}$  which do not contain the substring  $abaa$ .
33. [20 points] Give an unambiguous context-free grammar for the language of all regular expressions over the alphabet  $\{a, b\}$ . Your grammar should be consistent with the semantics of regular expressions.
34. [30 points] Let  $L$  be the set of all strings over  $\{a, b\}$  which have equal numbers of  $a$ 's and  $b$ 's. Prove, by contradiction, that  $L$  is not regular, as follows. First, you know that  $\{a^n b^n\}$  is not regular (don't prove it; you can just take it as given). Second, you know that  $\{a^i b^j\}$  is regular. (How do you know this?) Third, there is a theorem about intersections of regular language. Finally, obtain a contradiction.
35. [10 points] Indicate, using words and diagrams, how to prove that any 2-tape Turing machine can be emulated by a 1-tape Turing machine with a multiple track tape.
36. [20 points] Draw a transition-diagram (called “state diagram” in our textbook) for a Turing Machine that accepts  $\{a^n b^n | n \geq 0\}$ . (Do **not** draw a transition diagram for a PDA.)
37. [5 points each] Which of the problems below are known to be  $\mathcal{NP}$ -complete?
- (a) \_\_\_\_\_ The traveling salesman problem.
- (b) \_\_\_\_\_ Boolean satisfiability.
- (c) \_\_\_\_\_ The halting problem.
- (d) \_\_\_\_\_ Primality.
- (e) \_\_\_\_\_ The context-free grammar equivalence problem.

(f) \_\_\_\_\_ The independent set problem.

38. [10 points] State the pumping lemma for regular languages accurately. If you have all the right words but in the wrong order, that means you truly do not understand the lemma, and you might get no partial credit at all.
39. [10 points] State the pumping lemma for context-free languages accurately. If you have all the right words but in the wrong order, that means you truly do not understand the lemma, and you might get no partial credit at all.
40. [10 points] What does the Turing machine in figure 2 do?

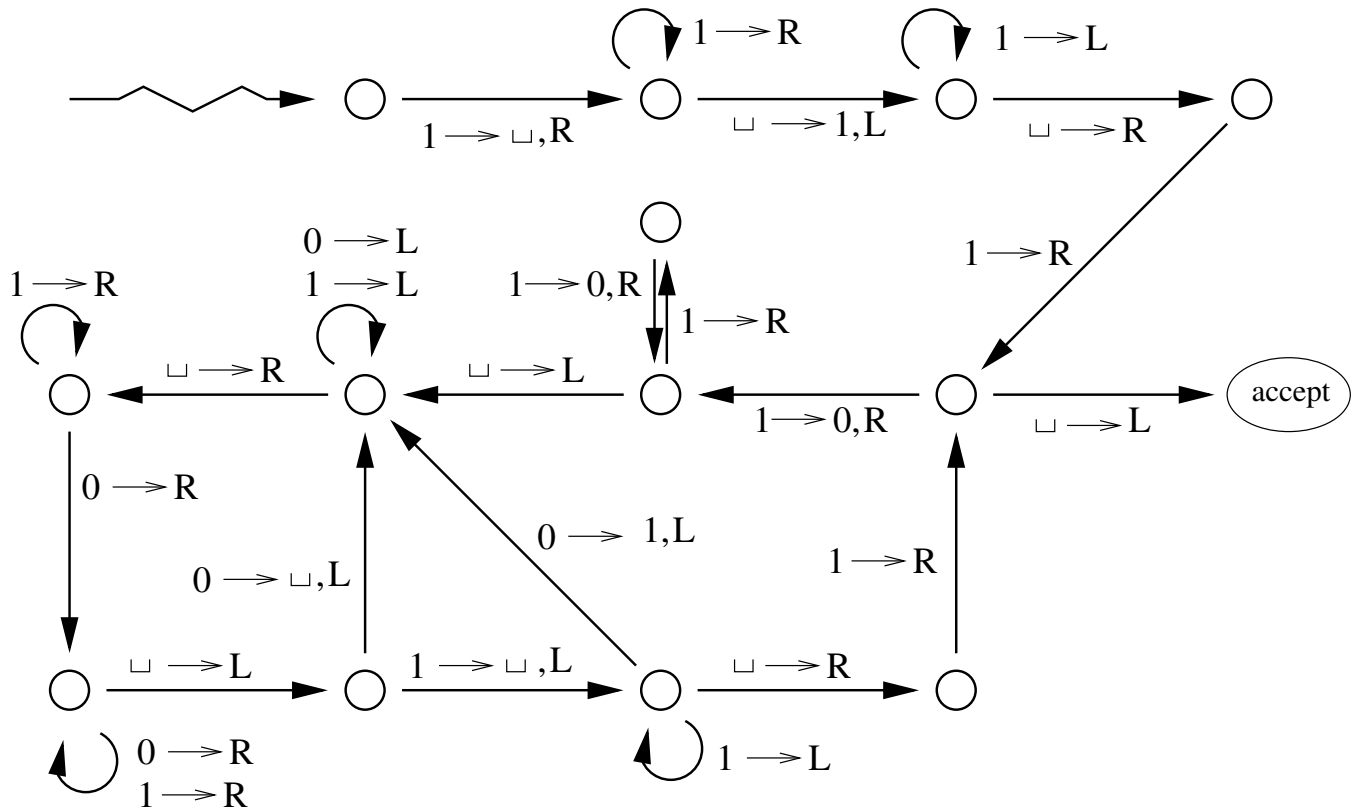

Figure 2: Turing machine for problem 40.

41. [30 points] Let  $H$  be a function whose prototype is:

```
int H(int n, bool x);
```

such that

- (a)  $H(n, x) < n/2$ ,
- (b) It takes  $O(\log n)$  time to compute  $H(n, x)$ .

Let  $\mathcal{B}$  be the set of unary numerals for “blue” numbers, where

- (c) 1 is blue.



- (d) If  $n > 1$ , then  $n$  is blue if and only if  $H(n, 0)$  is positive and blue, or  $H(n, 1)$  is positive and not blue

Prove that  $\mathcal{B}$  is in  $\mathcal{P}$ .

Explain why there is no easy proof that  $\mathcal{B}$  is in Nick's class, using only the above information.

42. [30 points] We define *Collatz* numbers as follows.

- (a) 1 is a Collatz number.  
(b) If  $n$  is a Collatz number, then  $2n$  is a Collatz number.  
(c) If  $n = 3m + 1$  is a Collatz number and  $m$  is an integer, then  $m$  is a Collatz number.  
(d) There are no Collatz numbers except for those that can be proved to be Collatz by using the above rules.

Let  $C$  be the set of binary numerals for Collatz numbers. Prove that  $C$  is recursively enumerable.

43. [30 points] Let  $\Sigma = \{0, 1\}$ , the binary alphabet. Let  $G$  be the unrestricted grammar whose terminal alphabet is  $\Sigma$ , whose start symbol is  $S$ , and whose productions are listed below:

$S \rightarrow LR$

$L \rightarrow L0Y$

$L \rightarrow LX$

$X1 \rightarrow 1X$

$X0 \rightarrow 0X$

$X0 \rightarrow 1Y$

$Y1 \rightarrow 0Y$

$YR \rightarrow R$

$L \rightarrow \epsilon$

$R \rightarrow \epsilon$

Describe  $L(G)$  in English using no more than four words.

44. [20 points] In class, we demonstrated that a language is in the class  $\mathcal{NP}$  if and only if it has a polynomial time *verifier*.

What is a polynomial time verifier of a language? Your explanation should include the word "certificate," or as it is sometimes known, "witness."

45. [30 points] **Warning: this problem requires you to go beyond the contents of the lectures.** Prove that the class of regular languages is a subclass of  $\mathcal{NC}$  (Nick's class).

46. [30 points] **Warning: this problem is very hard.** Every sliding block puzzle

[http://www.maa.org/editorial/mathgames/mathgames\\_12\\_13\\_04.html](http://www.maa.org/editorial/mathgames/mathgames_12_13_04.html)

can be encoded as a string of bits. All sliding block puzzles that you read about are solvable, or else they wouldn't be proposed, but you could obviously make up a sliding block puzzle that has no solution.

Do you believe that the set of encodings of solvable sliding block puzzles is  $\mathcal{NP}$ ? Explain your opinion.