

Chapter 8, Problem 1.

For the circuit in Fig. 8.62, find:

- (a) $i(0^+)$ and $v(0^+)$,
- (b) $di(0^+)/dt$ and $dv(0^+)/dt$,
- (c) $i(\infty)$ and $v(\infty)$.

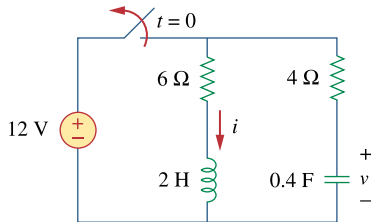
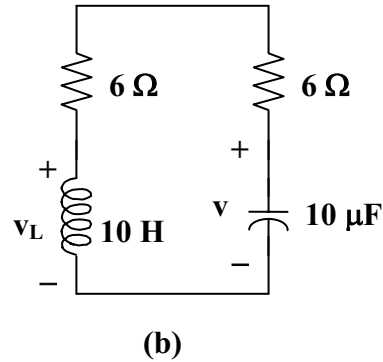
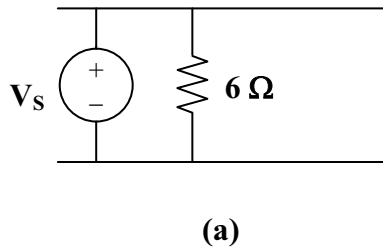

Figure 8.62
For Prob. 8.1.

Chapter 8, Solution 1.

(a) At $t = 0^-$, the circuit has reached steady state so that the equivalent circuit is shown in Figure (a).



$$i(0^-) = 12/6 = 2\text{A}, v(0^-) = 12\text{V}$$

$$\text{At } t = 0^+, i(0^+) = i(0^-) = \underline{2\text{A}}, v(0^+) = v(0^-) = \underline{12\text{V}}$$

(b) For $t > 0$, we have the equivalent circuit shown in Figure (b).

$$v_L = Ldi/dt \text{ or } di/dt = v_L/L$$

Applying KVL at $t = 0^+$, we obtain,

$$v_L(0^+) - v(0^+) + 10i(0^+) = 0$$

$$v_L(0^+) - 12 + 20 = 0, \text{ or } v_L(0^+) = -8$$

Hence, $di(0^+)/dt = -8/2 = \underline{-4\text{ A/s}}$

Similarly, $i_C = Cdv/dt, \text{ or } dv/dt = i_C/C$

$$i_C(0^+) = -i(0^+) = -2$$

$$dv(0^+)/dt = -2/0.4 = \underline{-5\text{ V/s}}$$

(c) As t approaches infinity, the circuit reaches steady state.

$$i(\infty) = \underline{0\text{ A}}, v(\infty) = \underline{0\text{ V}}$$

Chapter 8, Problem 2.

In the circuit of Fig. 8.63, determine:

- (a) $i_R(0^+)$, $i_L(0^+)$, and $i_C(0^+)$,
- (b) $di_R(0^+)/dt$, $di_L(0^+)/dt$, and $di_C(0^+)/dt$,
- (c) $i_R(\infty)$, $i_L(\infty)$, and $i_C(\infty)$.

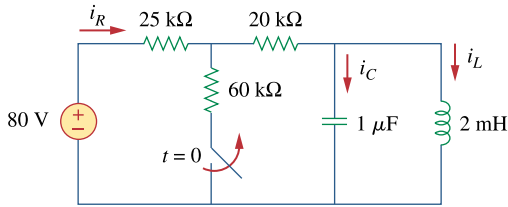
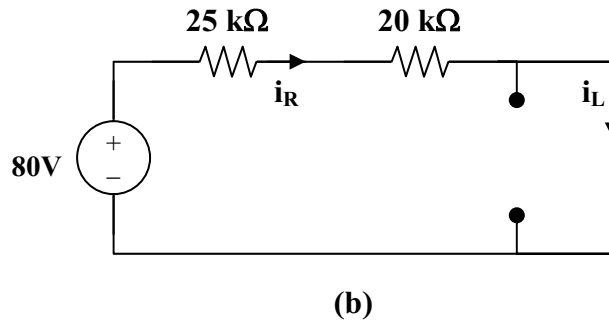
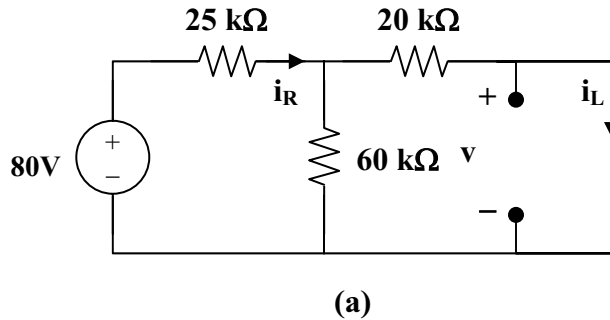

Figure 8.63
For Prob. 8.2.

Chapter 8, Solution 2.

- (a) At $t = 0^-$, the equivalent circuit is shown in Figure (a).



$$60 \parallel 20 = 15 \text{ kohms}, \quad i_R(0^-) = 80 / (25 + 15) = 2 \text{ mA}.$$

By the current division principle,

$$i_L(0^-) = 60(2\text{mA})/(60 + 20) = 1.5 \text{ mA}$$

$$v_C(0^-) = 0$$

At $t = 0^+$,

$$v_C(0^+) = v_C(0^-) = 0$$

$$i_L(0^+) = i_L(0^-) = \underline{1.5 \text{ mA}}$$

$$80 = i_R(0^+)(25 + 20) + v_C(0^-)$$

$$i_R(0^+) = 80/45\text{k} = \underline{1.778 \text{ mA}}$$

But,

$$i_R = i_C + i_L$$

$$1.778 = i_C(0^+) + 1.5 \text{ or } i_C(0^+) = \underline{0.278 \text{ mA}}$$

(b)

$$v_L(0^+) = v_C(0^+) = 0$$

$$\text{But, } v_L = L di_L/dt \text{ and } di_L(0^+)/dt = v_L(0^+)/L = 0$$

$$di_L(0^+)/dt = \underline{0}$$

$$\text{Again, } 80 = 45i_R + v_C$$

$$0 = 45 di_R/dt + dv_C/dt$$

$$\text{But, } dv_C(0^+)/dt = i_C(0^+)/C = 0.278 \text{ mA}/1 \mu\text{F} = 278 \text{ V/s}$$

$$\text{Hence, } di_R(0^+)/dt = (-1/45)dv_C(0^+)/dt = -278/45$$

$$di_R(0^+)/dt = \underline{-6.1778 \text{ A/s}}$$

$$\text{Also, } i_R = i_C + i_L$$

$$di_R(0^+)/dt = di_C(0^+)/dt + di_L(0^+)/dt$$

$$-6.1788 = di_C(0^+)/dt + 0, \text{ or } di_C(0^+)/dt = \underline{-6.1788 \text{ A/s}}$$

(c)

As t approaches infinity, we have the equivalent circuit in Figure (b).

$$i_R(\infty) = i_L(\infty) = 80/45\text{k} = \underline{1.778 \text{ mA}}$$

$$i_C(\infty) = C dv(\infty)/dt = \underline{0}.$$

PROPRIETARY MATERIAL. © 2007 The McGraw-Hill Companies, Inc. All rights reserved. No part of this Manual may be displayed, reproduced or distributed in any form or by any means, without the prior written permission of the publisher, or used beyond the limited distribution to teachers and educators permitted by McGraw-Hill for their individual course preparation. If you are a student using this Manual, you are using it without permission.

Chapter 8, Problem 3.

Refer to the circuit shown in Fig. 8.64. Calculate:

- $i_L(0^+)$, $v_C(0^+)$ and $v_R(0^+)$,
- $di_L(0^+)/dt$, $dv_C(0^+)/dt$, and $dv_R(0^+)/dt$,
- $i_L(\infty)$, $v_C(\infty)$ and $v_R(\infty)$

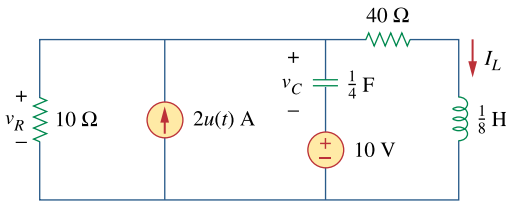

Figure 8.64
For Prob. 8.3.

Chapter 8, Solution 3.

At $t = 0^-$, $u(t) = 0$. Consider the circuit shown in Figure (a). $i_L(0^-) = 0$, and $v_R(0^-) = 0$. But, $-v_R(0^-) + v_C(0^-) + 10 = 0$, or $v_C(0^-) = -10\text{V}$.

- At $t = 0^+$, since the inductor current and capacitor voltage cannot change abruptly, the inductor current must still be equal to 0A , the capacitor has a voltage equal to -10V . Since it is in series with the $+10\text{V}$ source, together they represent a direct short at $t = 0^+$. This means that the entire 2A from the current source flows through the capacitor and not the resistor. Therefore, $v_R(0^+) = \underline{0\text{V}}$.

- (b) At $t = 0^+$, $v_L(0^+) = 0$, therefore $L di_L(0^+)/dt = v_L(0^+) = 0$, thus, $di_L/dt = \underline{0 \text{ A/s}}$, $i_C(0^+) = 2 \text{ A}$, this means that $dv_C(0^+)/dt = 2/C = \underline{8 \text{ V/s}}$. Now for the value of $dv_R(0^+)/dt$. Since $v_R = v_C + 10$, then $dv_R(0^+)/dt = dv_C(0^+)/dt + 0 = \underline{8 \text{ V/s}}$.

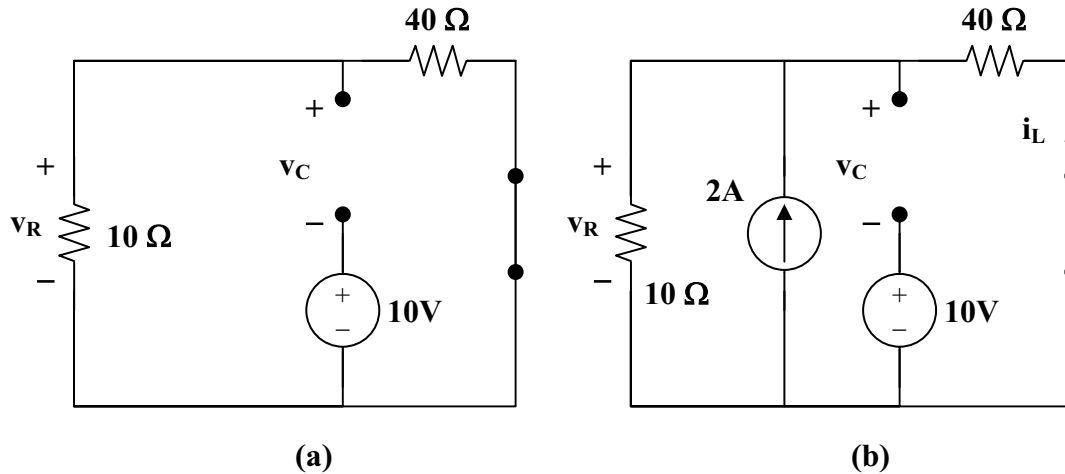

- (c) As t approaches infinity, we end up with the equivalent circuit shown in Figure (b).

$$i_L(\infty) = 10(2)/(40 + 10) = \underline{400 \text{ mA}}$$

$$v_C(\infty) = 2[10||40] - 10 = 16 - 10 = \underline{6 \text{ V}}$$

$$v_R(\infty) = 2[10||40] = \underline{16 \text{ V}}$$

Chapter 8, Problem 4.

In the circuit of Fig. 8.65, find:

- (a) $v(0^+)$ and $i(0^+)$,
- (b) $dv(0^+)/dt$ and $di(0^+)/dt$,
- (c) $v(\infty)$ and $i(\infty)$.

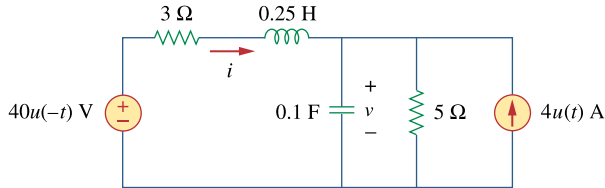

Figure 8.65

For Prob. 8.4.

Chapter 8, Solution 4.

(a) At $t = 0^-$, $u(-t) = 1$ and $u(t) = 0$ so that the equivalent circuit is shown in Figure (a).

$$i(0^-) = 40/(3 + 5) = 5\text{A}, \text{ and } v(0^-) = 5i(0^-) = 25\text{V}.$$

Hence,

$$i(0^+) = i(0^-) = \underline{5\text{A}}$$

$$v(0^+) = v(0^-) = \underline{25\text{V}}$$

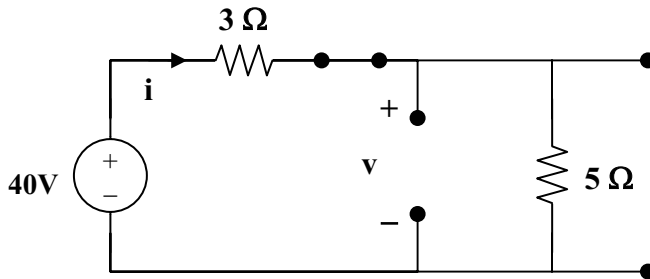

(a)

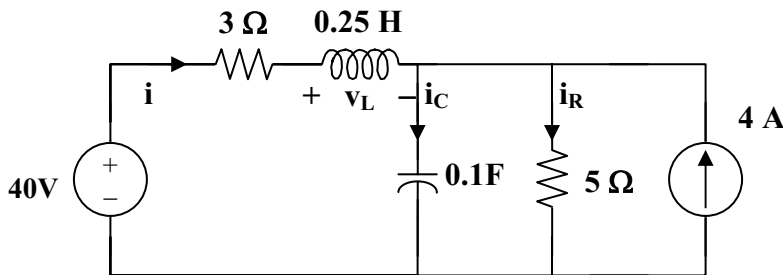

(b)

$$(b) \quad i_C = Cdv/dt \text{ or } dv(0^+)/dt = i_C(0^+)/C$$

For $t = 0^+$, $4u(t) = 4$ and $4u(-t) = 0$. The equivalent circuit is shown in Figure (b). Since i and v cannot change abruptly,

$$i_R = v/5 = 25/5 = 5A, \quad i(0^+) + 4 = i_C(0^+) + i_R(0^+)$$

$$5 + 4 = i_C(0^+) + 5 \text{ which leads to } i_C(0^+) = 4$$

$$dv(0^+)/dt = 4/0.1 = \underline{\underline{40 \text{ V/s}}}$$

Similarly,

$$v_L = Ldi/dt \text{ which leads to } di(0^+)/dt = v_L(0^+)/L$$

$$3i(0^+) + v_L(0^+) + v(0^+) = 0$$

$$15 + v_L(0^+) + 25 = 0 \text{ or } v_L(0^+) = -40$$

$$di(0^+)/dt = -40/0.25 = \underline{\underline{-160 \text{ A/s}}}$$

(c) As t approaches infinity, we have the equivalent circuit in Figure (c).

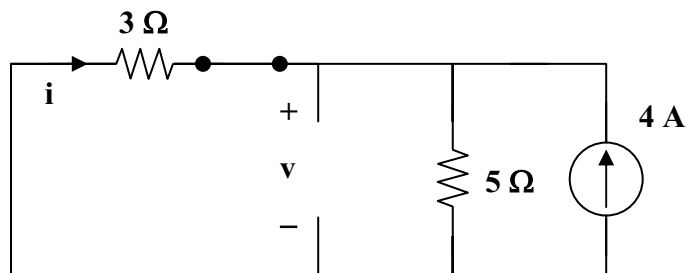

(c)

$$i(\infty) = -5(4)/(3 + 5) = \underline{\underline{-2.5 \text{ A}}}$$

$$v(\infty) = 5(4 - 2.5) = \underline{\underline{7.5 \text{ V}}}$$

Chapter 8, Problem 5.

Refer to the circuit in Fig. 8.66. Determine:

- (a) $i(0^+)$ and $v(0^+)$,
- (b) $di(0^+)/dt$ and $dv(0^+)/dt$,
- (c) $i(\infty)$ and $v(\infty)$.

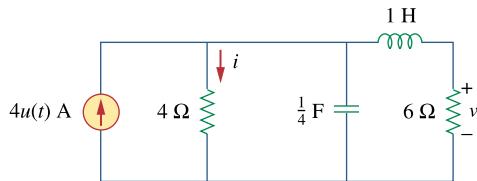

Figure 8.66
For Prob. 8.5.

Chapter 8, Solution 5.

- (a) For $t < 0$, $4u(t) = 0$ so that the circuit is not active (all initial conditions = 0).

$$i_L(0^-) = 0 \text{ and } v_C(0^-) = 0.$$

For $t = 0^+$, $4u(t) = 4$. Consider the circuit below.

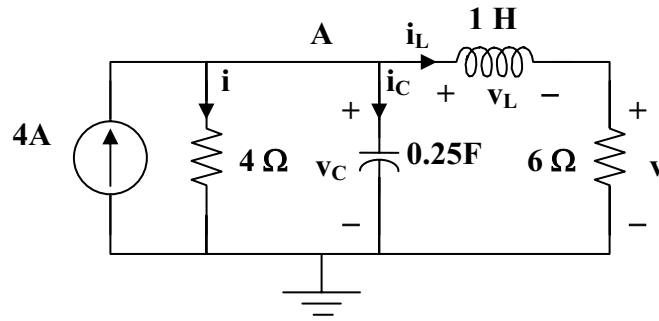

Since the 4-ohm resistor is in parallel with the capacitor,

$$i(0^+) = v_C(0^+)/4 = 0/4 = \underline{\mathbf{0 \text{ A}}}$$

Also, since the 6-ohm resistor is in series with the inductor,
 $v(0^+) = 6i_L(0^+) = \underline{\mathbf{0 \text{ V}}}$.

- (b) $di(0^+)/dt = d(v_R(0^+)/R)/dt = (1/R)dv_R(0^+)/dt = (1/R)dv_C(0^+)/dt$
 $= (1/4)4/0.25 \text{ A/s} = \underline{\mathbf{4 \text{ A/s}}}$

$$v = 6i_L \text{ or } dv/dt = 6di_L/dt \text{ and } dv(0^+)/dt = 6di_L(0^+)/dt = 6v_L(0^+)/L = 0$$

$$\text{Therefore } dv(0^+)/dt = \underline{\mathbf{0 \text{ V/s}}}$$

- (c) As t approaches infinity, the circuit is in steady-state.

$$i(\infty) = 6(4)/10 = \underline{\mathbf{2.4 \text{ A}}}$$

$$v(\infty) = 6(4 - 2.4) = \underline{\mathbf{9.6 \text{ V}}}$$

Chapter 8, Problem 6.

In the circuit of Fig. 8.67, find:

- (a) $v_R(0^+)$ and $v_L(0^+)$,
- (b) $dv_R(0^+)/dt$ and $dv_L(0^+)/dt$,
- (c) $v_R(\infty)$ and $v_L(\infty)$,

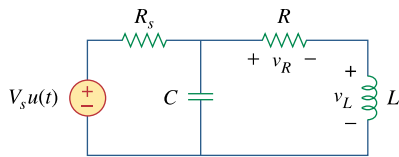

Figure 8.67
For Prob. 8.6.

Chapter 8, Solution 6.

(a) Let i = the inductor current. For $t < 0$, $u(t) = 0$ so that

$$i(0) = 0 \text{ and } v(0) = 0.$$

For $t > 0$, $u(t) = 1$. Since, $v(0^+) = v(0^-) = 0$, and $i(0^+) = i(0^-) = 0$.

$$v_R(0^+) = Ri(0^+) = \underline{0 \text{ V}}$$

Also, since $v(0^+) = v_R(0^+) + v_L(0^+) = 0 = 0 + v_L(0^+)$ or $v_L(0^+) = \underline{0 \text{ V}}$.

(1)

(b) Since $i(0^+) = 0$, $i_C(0^+) = V_S/R_S$

But, $i_C = Cdv/dt$ which leads to $dv(0^+)/dt = V_S/(CR_S)$ (2)

From (1), $dv(0^+)/dt = dv_R(0^+)/dt + dv_L(0^+)/dt$ (3)

$v_R = iR$ or $dv_R/dt = Rdi/dt$ (4)

But, $v_L = Ldi/dt$, $v_L(0^+) = 0 = Ldi(0^+)/dt$ and $di(0^+)/dt = 0$ (5)

From (4) and (5), $dv_R(0^+)/dt = \underline{0 \text{ V/s}}$

From (2) and (3), $dv_L(0^+)/dt = dv(0^+)/dt = \underline{V_S/(CR_S)}$

(c) As t approaches infinity, the capacitor acts like an open circuit, while the inductor acts like a short circuit.

$$v_R(\infty) = \underline{[R/(R + R_S)]V_S}$$

$$v_L(\infty) = \underline{0 \text{ V}}$$

Chapter 8, Problem 7.

A series RLC circuit has $R = 10\text{k}\Omega$, $L = 0.1\text{ mH}$, and $C = 10\mu\text{ F}$. What type of damping is exhibited by the circuit?

Chapter 8, Solution 7.

$$\alpha = \frac{R}{2L} = \frac{10 \times 10^3}{2 \times 0.1 \times 10^{-3}} = 50 \times 10^6$$

$$\omega_o = \frac{1}{\sqrt{LC}} = \frac{1}{\sqrt{0.1 \times 10^{-3} \times 10 \times 10^{-6}}} = 3.162 \times 10^4$$

$$\alpha > \omega_o \quad \longrightarrow \quad \underline{\text{overdamped}}$$

Chapter 8, Problem 8.

A branch current is described by

$$\frac{d^2 i(t)}{dt^2} + 4 \frac{di(t)}{dt} + 10i(t) = 0$$

Determine: (a) the characteristic equation, (b) the type of damping exhibited by the circuit, (c) $i(t)$ given that $i(0) = 1$ and $di(0)/dt = 2$.

Chapter 8, Solution 8.

(a) The characteristic equation is $\underline{s^2 + 4s + 10 = 0}$

(b) $s_{1,2} = \frac{-4 \pm \sqrt{16 - 40}}{2} = -2 \pm j2.45$

This is underdamped case.

(c) $i(t) = (A \cos 2.45t + B \sin 2.45t)e^{-2t}$

$$\frac{di}{dt} = (-2A \cos 2.45t - 2B \sin 2.45t - 2.45A \sin 2.45t + 2.45B \cos 2.45t)e^{-2t}$$

$$i(0) = 1 = A$$

$$di(0)/dt = 2 = -2A + 2.45B = -2 + 2.45B \quad \text{or} \quad B = 1.6327$$

$$i(t) = \underline{\{\cos(2.45t) + 1.6327\sin(2.45t)\}e^{-2t} \text{ A.}}$$

Please note that this problem can be checked using MATLAB.

PROPRIETARY MATERIAL. © 2007 The McGraw-Hill Companies, Inc. All rights reserved. No part of this Manual may be displayed, reproduced or distributed in any form or by any means, without the prior written permission of the publisher, or used beyond the limited distribution to teachers and educators permitted by McGraw-Hill for their individual course preparation. If you are a student using this Manual, you are using it without permission.

Chapter 8, Problem 9.

The current in an *RLC* circuit is described by $\frac{d^2i}{dt^2} + 10\frac{di}{dt} + 25i = 0$

If $i(0) = 10$ and $di(0)/dt = 0$ find $i(t)$ for $t > 0$.

Chapter 8, Solution 9.

$$s^2 + 10s + 25 = 0, \text{ thus } s_{1,2} = \frac{-10 \pm \sqrt{10^2 - 100}}{2} = -5, \text{ repeated roots.}$$

$$i(t) = [(A + Bt)e^{-5t}], \quad i(0) = 10 = A$$

$$di/dt = [Be^{-5t}] + [-5(A + Bt)e^{-5t}]$$

$$di(0)/dt = 0 = B - 5A = B - 50 \text{ or } B = 50.$$

$$\text{Therefore, } i(t) = \underline{\underline{[(10 + 50t)e^{-5t}] \text{ A}}}$$

Chapter 8, Problem 10.

The differential equation that describes the voltage in an *RLC* network is

$$\frac{d^2v}{dt^2} + 5\frac{dv}{dt} + 4v = 0$$

Given that $v(0) = 0$, $dv(0)/dt = 10$ obtain $v(t)$.

Chapter 8, Solution 10.

$$s^2 + 5s + 4 = 0, \text{ thus } s_{1,2} = \frac{-5 \pm \sqrt{25 - 16}}{2} = -4, -1.$$

$$v(t) = (Ae^{-4t} + Be^{-t}), \quad v(0) = 0 = A + B, \text{ or } B = -A$$

$$dv/dt = (-4Ae^{-4t} - Be^{-t})$$

$$dv(0)/dt = 10 = -4A - B = -3A \text{ or } A = -10/3 \text{ and } B = 10/3.$$

$$\text{Therefore, } v(t) = \underline{\underline{(-10/3)e^{-4t} + (10/3)e^{-t}] \text{ V}}}$$

PROPRIETARY MATERIAL. © 2007 The McGraw-Hill Companies, Inc. All rights reserved. No part of this Manual may be displayed, reproduced or distributed in any form or by any means, without the prior written permission of the publisher, or used beyond the limited distribution to teachers and educators permitted by McGraw-Hill for their individual course preparation. If you are a student using this Manual, you are using it without permission.

Chapter 8, Problem 11.

The natural response of an *RLC* circuit is described by the differential equation

$$\frac{d^2v}{dt^2} + 2\frac{dv}{dt} + v = 0$$

for which the initial conditions are $v(0) = 10$ and $dv(0)/dt = 0$ Solve for $v(t)$

Chapter 8, Solution 11.

$$s^2 + 2s + 1 = 0, \text{ thus } s_{1,2} = \frac{-2 \pm \sqrt{4-4}}{2} = -1, \text{ repeated roots.}$$

$$v(t) = [(A + Bt)e^{-t}], \quad v(0) = 10 = A$$

$$dv/dt = [Be^{-t}] + [-(A + Bt)e^{-t}]$$

$$dv(0)/dt = 0 = B - A = B - 10 \text{ or } B = 10.$$

$$\text{Therefore, } v(t) = \underline{[(10 + 10t)e^{-t}] \text{ V}}$$

Chapter 8, Problem 12.

If $R = 20\Omega, L = 0.6\text{H}$ what value of C will make an *RLC* series circuit:

- (a) overdamped,
- (b) critically damped,
- (c) underdamped?

Chapter 8, Solution 12.

- (a) Overdamped when $C > 4L/(R^2) = 4 \times 0.6/400 = 6 \times 10^{-3}$, or $C > \underline{6 \text{ mF}}$
- (b) Critically damped when $C = \underline{6 \text{ mF}}$
- (c) Underdamped when $C < \underline{6 \text{ mF}}$

Chapter 8, Problem 13.

For the circuit in Fig. 8.68, calculate the value of R needed to have a critically damped response.

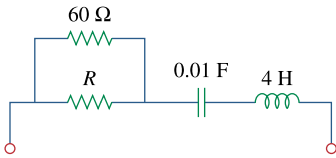

Figure 8.68

For Prob. 8.13.

Chapter 8, Solution 13.

Let $R \parallel 60 = R_o$. For a series RLC circuit,

$$\omega_o = \frac{1}{\sqrt{LC}} = \frac{1}{\sqrt{0.01 \times 4}} = 5$$

For critical damping, $\omega_o = \alpha = R_o/(2L) = 5$

$$\text{or } R_o = 10L = 40 = 60R/(60 + R)$$

which leads to $R = \underline{\underline{120 \text{ ohms}}}$

Chapter 8, Problem 14.

The switch in Fig. 8.69 moves from position *A* to position *B* at $t = 0$ (please note that the switch must connect to point *B* before it breaks the connection at *A*, a make-before-break switch). Find $v(t)$ for $t > 0$

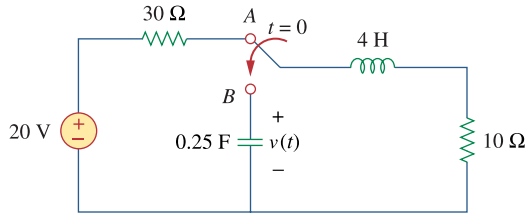

Figure 8.69

For Prob. 8.14.

Chapter 8, Solution 14.

When the switch is in position *A*, $v(0^-) = 0$ and $i_L(0^-) = \frac{20}{40} = 0.5\text{ A}$. When the switch is in position *B*, we have a source-free series RCL circuit.

$$\alpha = \frac{R}{2L} = \frac{10}{2 \times 4} = 1.25$$

$$\omega_o = \frac{1}{\sqrt{LC}} = \frac{1}{\sqrt{\frac{1}{4} \times 4}} = 1$$

Since $\alpha > \omega_o$, we have overdamped case.

$$s_{1,2} = -\alpha \pm \sqrt{\alpha^2 - \omega_o^2} = -1.25 \pm \sqrt{1.5625 - 1} = -0.5 \text{ and } -2$$

$$v(t) = Ae^{-2t} + Be^{-0.5t} \quad (1)$$

$$v(0) = 0 = A + B \quad (2)$$

$$i_C(0) = C \frac{dv(0)}{dt} = 0.5 \quad \longrightarrow \quad \frac{dv(0)}{dt} = \frac{0.5}{C} = 2$$

But $\frac{dv(t)}{dt} = -2Ae^{-2t} - 0.5Be^{-0.5t}$

$$\frac{dv(0)}{dt} = -2A - 0.5B = 2 \quad (3)$$

Solving (2) and (3) gives $A = -1.3333$ and $B = 1.3333$

$$v(t) = \underline{\underline{-1.3333e^{-2t} + 1.3333e^{-0.5t} \text{ V}}}$$

Chapter 8, Problem 15.

The responses of a series RLC circuit are

$$v_c(t) = 30 - 10e^{-20t} + 30e^{-10t} \text{ V}$$

$$i_L(t) = 40e^{-20t} - 60e^{-10t} \text{ mA}$$

where v_c and i_L are the capacitor voltage and inductor current, respectively. Determine the values of R , L , and C .

Chapter 8, Solution 15.

Given that $s_1 = -10$ and $s_2 = -20$, we recall that

$$s_{1,2} = -\alpha \pm \sqrt{\alpha^2 - \omega_0^2} = -10, -20$$

Clearly, $s_1 + s_2 = -2\alpha = -30$ or $\alpha = 15 = R/(2L)$ or $R = 60L$ (1)

$$s_1 = -15 + \sqrt{15^2 - \omega_0^2} = -10 \text{ which leads to } 15^2 - \omega_0^2 = 25$$

$$\text{or } \omega_0 = \sqrt{225 - 25} = \sqrt{200} = 1/\sqrt{LC}, \text{ thus } LC = 1/200 \quad (2)$$

Since we have a series RLC circuit, $i_L = i_C = Cdv_C/dt$ which gives,

$$i_L/C = dv_C/dt = [200e^{-20t} - 300e^{-30t}] \text{ or } i_L = 100C[2e^{-20t} - 3e^{-30t}]$$

But, i is also $= 20\{[2e^{-20t} - 3e^{-30t}] \times 10^{-3}\} = 100C[2e^{-20t} - 3e^{-30t}]$

$$\text{Therefore, } C = (0.02/10^2) = \underline{\underline{200 \mu\text{F}}}$$

$$L = 1/(200C) = \underline{\underline{25 \text{ H}}}$$

$$R = 30L = \underline{\underline{750 \text{ ohms}}}$$

Chapter 8, Problem 16.

Find $i(t)$ for $t > 0$ in the circuit of Fig. 8.70.

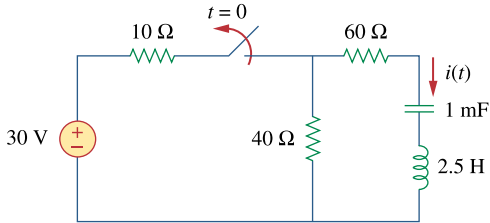

Figure 8.70
For Prob. 8.16.

Chapter 8, Solution 16.

$$\text{At } t = 0, i(0) = 0, v_C(0) = 40 \times 30 / 50 = 24\text{V}$$

For $t > 0$, we have a source-free RLC circuit.

$$\alpha = R/(2L) = (40 + 60)/5 = 20 \text{ and } \omega_o = \frac{1}{\sqrt{LC}} = \frac{1}{\sqrt{10^{-3} \times 2.5}} = 20$$

$$\omega_o = \alpha \text{ leads to critical damping}$$

$$i(t) = [(A + Bt)e^{-20t}], \quad i(0) = 0 = A$$

$$di/dt = \{[Be^{-20t}] + [-20(Bt)e^{-20t}]\},$$

$$\text{but } di(0)/dt = -(1/L)[Ri(0) + v_C(0)] = -(1/2.5)[0 + 24]$$

$$\text{Hence, } B = -9.6 \text{ or } i(t) = \underline{\underline{-9.6te^{-20t}}}\text{ A}$$

Chapter 8, Problem 17.

In the circuit of Fig. 8.71, the switch instantaneously moves from position A to B at $t = 0$. Find $v(t)$ for all $t \geq 0$.

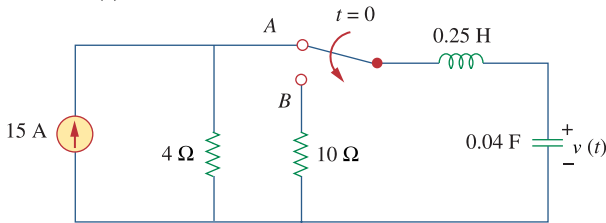

Figure 8.71
For Prob. 8.17.

Chapter 8, Solution 17.

$$i(0) = I_0 = 0, \quad v(0) = V_0 = 4 \times 15 = 60$$

$$\frac{di(0)}{dt} = -\frac{1}{L}(RI_0 + V_0) = -4(0 + 60) = -240$$

$$\omega_o = \frac{1}{\sqrt{LC}} = \frac{1}{\sqrt{\frac{1}{4} \frac{1}{25}}} = 10$$

$$\alpha = \frac{R}{2L} = \frac{10}{2 \frac{1}{4}} = 20, \text{ which is } > \omega_o.$$

$$s = -\alpha \pm \sqrt{\alpha^2 - \omega_o^2} = -20 \pm \sqrt{300} = -20 \pm 10\sqrt{3} = -2.679, -37.32$$

$$i(t) = A_1 e^{-2.679t} + A_2 e^{-37.32t}$$

$$i(0) = 0 = A_1 + A_2, \quad \frac{di(0)}{dt} = -2.679A_1 - 37.32A_2 = -240$$

$$\text{This leads to } A_1 = -6.928 = -A_2$$

$$i(t) = 6.928(e^{-37.32t} - e^{-2.679t})$$

$$\text{Since, } v(t) = \frac{1}{C} \int_0^t i(t) dt + \text{const, and } v(0) = 60\text{V, we get}$$

$$v(t) = \underline{\underline{(64.65e^{-2.679t} - 4.641e^{-37.32t}) \text{ V}}}$$

We note that $v(0) = 60.009\text{V}$ and not 60V . This is due to rounding errors since $v(t)$ must go to zero as time goes to infinity. {In other words, the constant of integration must be zero.

Chapter 8, Problem 18.

Find the voltage across the capacitor as a function of time for $t > 0$ for the circuit in Fig. 8.72. Assume steady-state conditions exist at $t = 0^-$

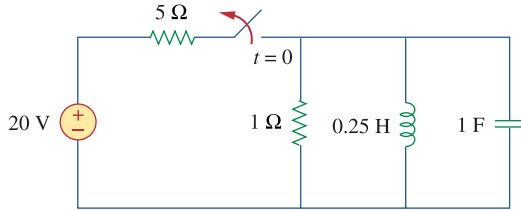

Figure 8.72
For Prob. 8.18.

Chapter 8, Solution 18.

When the switch is off, we have a source-free parallel RLC circuit.

$$\omega_o = \frac{1}{\sqrt{LC}} = \frac{1}{\sqrt{0.25 \times 1}} = 2, \quad \alpha = \frac{1}{2RC} = 0.5$$

$$\alpha < \omega_o \quad \longrightarrow \quad \text{underdamped case} \quad \omega_d = \sqrt{\omega_o^2 - \alpha^2} = \sqrt{4 - 0.25} = 1.936$$

$$I_o(0) = i(0) = \text{initial inductor current} = 20/5 = 4\text{A}$$

$$V_o(0) = v(0) = \text{initial capacitor voltage} = 0\text{ V}$$

$$v(t) = e^{-\alpha t} (A_1 \cos \omega_d t + A_2 \sin \omega_d t) = e^{-0.5\alpha t} (A_1 \cos 1.936t + A_2 \sin 1.936t)$$

$$v(0) = 0 = A_1$$

$$\frac{dv}{dt} = e^{-0.5\alpha t} (-0.5)(A_1 \cos 1.936t + A_2 \sin 1.936t) + e^{-0.5\alpha t} (-1.936A_1 \sin 1.936t + 1.936A_2 \cos 1.936t)$$

$$\frac{dv(0)}{dt} = -\frac{(V_o + RI_o)}{RC} = -\frac{(0 + 4)}{1} = -4 = -0.5A_1 + 1.936A_2 \quad \longrightarrow \quad A_2 = -2.066$$

Thus,

$$\underline{v(t) = -2.066e^{-0.5t} \sin 1.936t}$$

Chapter 8, Problem 19.

Obtain $v(t)$ for $t > 0$ in the circuit of Fig. 8.73.

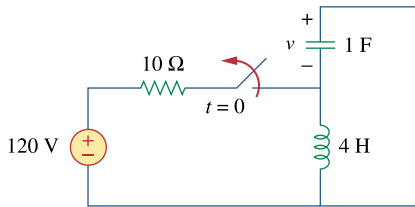
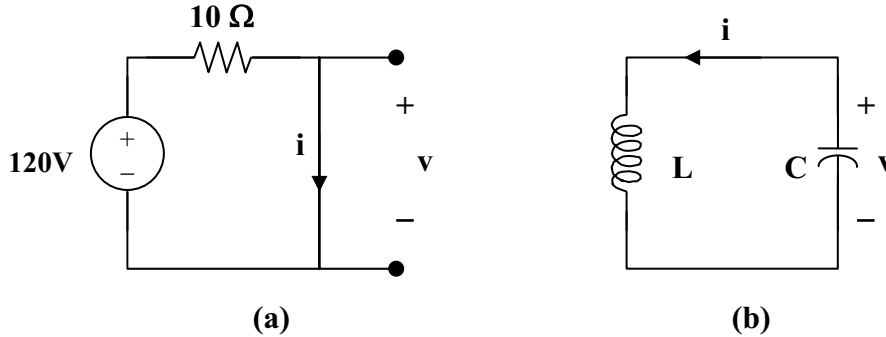

Figure 8.73
For Prob. 8.19.

Chapter 8, Solution 19.

For $t < 0$, the equivalent circuit is shown in Figure (a).



$$i(0) = 120/10 = 12, \quad v(0) = 0$$

For $t > 0$, we have a series RLC circuit as shown in Figure (b) with $R = 0 = \alpha$.

$$\omega_o = \frac{1}{\sqrt{LC}} = \frac{1}{\sqrt{4}} = 0.5 = \omega_d$$

$$i(t) = [A\cos 0.5t + B\sin 0.5t], \quad i(0) = 12 = A$$

$$v = -Ldi/dt, \quad \text{and} \quad -v/L = di/dt = 0.5[-12\sin 0.5t + B\cos 0.5t],$$

$$\text{which leads to } -v(0)/L = 0 = B$$

$$\text{Hence,} \quad i(t) = 12\cos 0.5t \text{ A and } v = 0.5$$

$$\text{However, } v = -Ldi/dt = -4(0.5)[-12\sin 0.5t] = \underline{\underline{24\sin 0.5t \text{ V}}}$$

Chapter 8, Problem 20.

The switch in the circuit of Fig. 8.74 has been closed for a long time but is opened at $t = 0$. Determine $i(t)$ for $t > 0$.

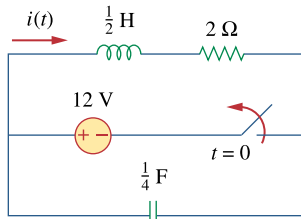
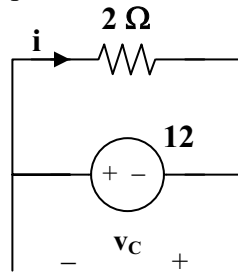

Figure 8.74
For Prob. 8.20.

Chapter 8, Solution 20.

For $t < 0$, the equivalent circuit is as shown below.



$$v(0) = -12\text{V} \text{ and } i(0) = 12/2 = 6\text{A}$$

For $t > 0$, we have a series RLC circuit.

$$\alpha = R/(2L) = 2/(2 \times 0.5) = 2$$

$$\omega_0 = 1/\sqrt{LC} = 1/\sqrt{0.5 \times 1/4} = 2\sqrt{2}$$

Since α is less than ω_0 , we have an under-damped response.

$$\omega_d = \sqrt{\omega_0^2 - \alpha^2} = \sqrt{8 - 4} = 2$$

$$i(t) = (A\cos 2t + B\sin 2t)e^{-2t}$$

$$i(0) = 6 = A$$

$$di/dt = -2(6\cos 2t + B\sin 2t)e^{-2t} + (-2 \times 6\sin 2t + 2B\cos 2t)e^{-2t}$$

$$di(0)/dt = -12 + 2B = -(1/L)[Ri(0) + v_C(0)] = -2[12 - 12] = 0$$

$$\text{Thus, } B = 6 \text{ and } i(t) = \underline{\underline{(6\cos 2t + 6\sin 2t)e^{-2t} \text{ A}}}$$

Chapter 8, Problem 21.



* Calculate $v(t)$ for $t > 0$ in the circuit of Fig. 8.75.

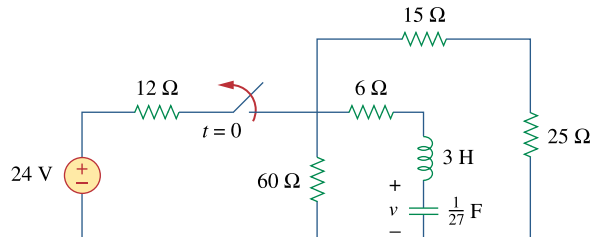

Figure 8.75

For Prob. 8.21.

* An asterisk indicates a challenging problem.

Chapter 8, Solution 21.

By combining some resistors, the circuit is equivalent to that shown below.

$$60 \parallel (15 + 25) = 24 \text{ ohms.}$$

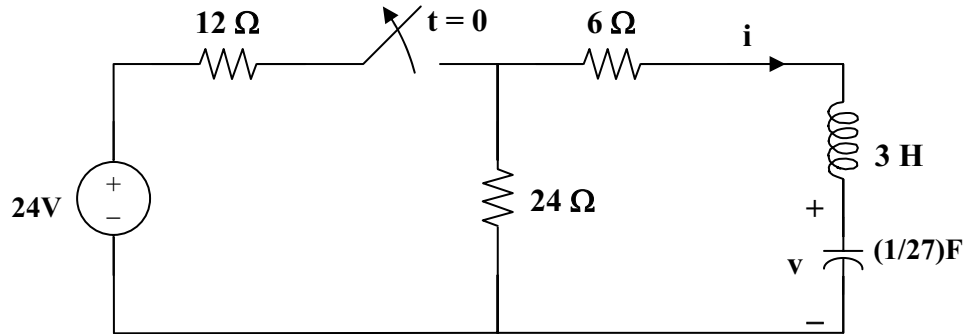

At $t = 0^-$, $i(0) = 0$, $v(0) = 24 \times 24 / 36 = 16\text{V}$

For $t > 0$, we have a series RLC circuit. $R = 30 \text{ ohms}$, $L = 3 \text{ H}$, $C = (1/27) \text{ F}$

$$\alpha = R/(2L) = 30/6 = 5$$

$$\omega_0 = 1/\sqrt{LC} = 1/\sqrt{3 \times 1/27} = 3, \text{ clearly } \alpha > \omega_0 \text{ (overdamped response)}$$

$$s_{1,2} = -\alpha \pm \sqrt{\alpha^2 - \omega_0^2} = -5 \pm \sqrt{5^2 - 3^2} = -9, -1$$

$$v(t) = [Ae^{-t} + Be^{-9t}], \quad v(0) = 16 = A + B \tag{1}$$

$$i = Cdv/dt = C[-Ae^{-t} - 9Be^{-9t}]$$

$$i(0) = 0 = C[-A - 9B] \text{ or } A = -9B \tag{2}$$

From (1) and (2), $B = -2$ and $A = 18$.

Hence, $v(t) = \underline{\underline{(18e^{-t} - 2e^{-9t}) \text{ V}}}$

Chapter 8, Problem 22.

Assuming $R = 2\text{ k}\Omega$, design a parallel RLC circuit that has the characteristic equation $s^2 + 100s + 10^6 = 0$.

Chapter 8, Solution 22.

Compare the characteristic equation with eq. (8.8), i.e.

$$s^2 + \frac{R}{L}s + \frac{1}{LC} = 0$$

we obtain

$$\frac{R}{L} = 100 \quad \longrightarrow \quad L = \frac{R}{100} = \frac{2000}{100} = \underline{20\text{H}}$$

$$\frac{1}{LC} = 10^6 \quad \rightarrow \quad C = \frac{1}{10^6 L} = \frac{10^{-6}}{20} = \underline{50\text{ nF}}$$

Chapter 8, Problem 23.

For the network in Fig. 8.76, what value of C is needed to make the response underdamped with unity damping factor $\alpha = 1$?

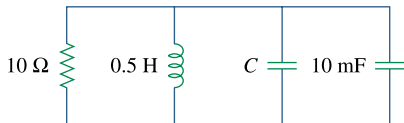

Figure 8.76

For Prob. 8.23.

Chapter 8, Solution 23.

Let $C_0 = C + 0.01$. For a parallel RLC circuit,

$$\alpha = 1/(2RC_0), \quad \omega_0 = 1/\sqrt{LC_0}$$

$$\alpha = 1 = 1/(2RC_0), \quad \text{we then have } C_0 = 1/(2R) = 1/20 = 50\text{ mF}$$

$$\omega_0 = 1/\sqrt{0.5 \times 0.5} = 6.32 > \alpha \text{ (underdamped)}$$

$$C_0 = C + 10\text{ mF} = 50\text{ mF} \text{ or } \underline{\underline{40\text{ mF}}}$$

Chapter 8, Problem 24.

The switch in Fig. 8.77 moves from position *A* to position *B* at $t = 0$ (please note that the switch must connect to point *B* before it breaks the connection at *A*, a make-before-break switch). Determine $i(t)$ for $t > 0$

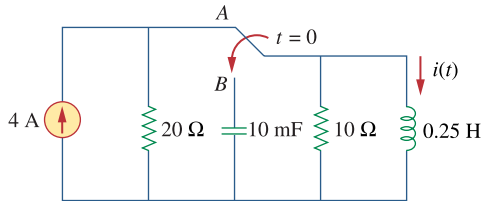

Figure 8.77

For Prob. 8.24.

Chapter 8, Solution 24.

When the switch is in position *A*, the inductor acts like a short circuit so

$$i(0^-) = 4$$

When the switch is in position *B*, we have a source-free parallel RCL circuit

$$\alpha = \frac{1}{2RC} = \frac{1}{2 \times 10 \times 10 \times 10^{-3}} = 5$$

$$\omega_o = \frac{1}{\sqrt{LC}} = \frac{1}{\sqrt{\frac{1}{4} \times 10 \times 10^{-3}}} = 20$$

Since $\alpha < \omega_o$, we have an underdamped case.

$$s_{1,2} = -5 + \sqrt{25 - 400} = -5 + j19.365$$

$$i(t) = e^{-5t} (A_1 \cos 19.365t + A_2 \sin 19.365t)$$

$$i(0) = 4 = A_1$$

$$v = L \frac{di}{dt} \longrightarrow \frac{di(0)}{dt} = \frac{v(0)}{L} = 0$$

$$\frac{di}{dt} = e^{-5t} (-5A_1 \cos 19.365t - 5A_2 \sin 19.365t - 19.365A_1 \sin 19.365t + 19.365A_2 \cos 19.365t)$$

$$0 = \frac{di(0)}{dt} = -5A_1 + 19.365A_2 \longrightarrow A_2 = \frac{5A_1}{19.365} = 1.033$$

$$i(t) = e^{-5t} (4 \cos 19.365t + 1.033 \sin 19.365t)$$

Chapter 8, Problem 25.

In the circuit of Fig. 8.78, calculate $i_o(t)$ and $v_o(t)$ for $t > 0$

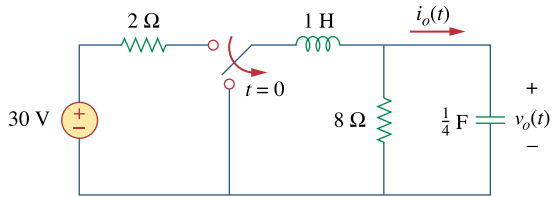

Figure 8.78

For Prob. 8.25.

Chapter 8, Solution 25.

In the circuit in Fig. 8.76, calculate $i_o(t)$ and $v_o(t)$ for $t > 0$.

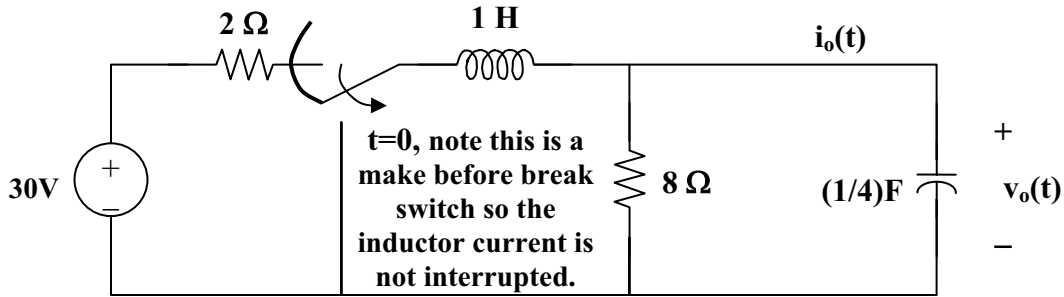

Figure 8.78 For Problem 8.25.

At $t = 0^-$, $v_o(0) = (8/(2 + 8))(30) = 24$

For $t > 0$, we have a source-free parallel RLC circuit.

$$\alpha = 1/(2RC) = 1/4$$

$$\omega_o = 1/\sqrt{LC} = 1/\sqrt{1 \times 1/4} = 2$$

Since α is less than ω_o , we have an under-damped response.

$$\omega_d = \sqrt{\omega_o^2 - \alpha^2} = \sqrt{4 - (1/16)} = 1.9843$$

$$v_o(t) = (A_1 \cos \omega_d t + A_2 \sin \omega_d t) e^{-\alpha t}$$

$$v_o(0) = 30(8/(2+8)) = 24 = A_1 \text{ and } i_o(t) = C(dv_o/dt) = 0 \text{ when } t = 0.$$

$$dv_o/dt = -\alpha(A_1 \cos \omega_d t + A_2 \sin \omega_d t) e^{-\alpha t} + (-\omega_d A_1 \sin \omega_d t + \omega_d A_2 \cos \omega_d t) e^{-\alpha t}$$

$$\text{at } t = 0, \text{ we get } dv_o(0)/dt = 0 = -\alpha A_1 + \omega_d A_2$$

Thus, $A_2 = (\alpha/\omega_d)A_1 = (1/4)(24)/1.9843 = 3.024$

$$v_o(t) = \underline{\underline{(24 \cos 1.9843t + 3.024 \sin 1.9843t) e^{-t/4} \text{ volts.}}}$$

$$\begin{aligned} i_o(t) &= Cdv/dt = 0.25[-24(1.9843)\sin 1.9843t + 3.024(1.9843)\cos 1.9843t - \\ &0.25(24\cos 1.9843t) - 0.25(3.024\sin 1.9843t)]e^{-t/4} \\ &= \underline{\underline{[0.000131 \cos 1.9843t - 12.095 \sin 1.9843t] e^{-t/4} \text{ A.}}} \end{aligned}$$

Chapter 8, Problem 26.

The step response of an *RLC* circuit is described by

$$\frac{d^2i}{dt^2} + 2\frac{di}{dt} + 5i = 10$$

Given that $i(0) = 2$ and $di(0)/dt = 4$, solve for $i(t)$

Chapter 8, Solution 26.

$$s^2 + 2s + 5 = 0, \text{ which leads to } s_{1,2} = \frac{-2 \pm \sqrt{4 - 20}}{2} = -1 \pm j4$$

$$i(t) = I_s + [(A_1 \cos 4t + A_2 \sin 4t)e^{-t}], \quad I_s = 10/5 = 2$$

$$i(0) = 2 = 2 + A_1, \text{ or } A_1 = 0$$

$$di/dt = [(A_2 \cos 4t)e^{-t}] + [(-A_2 \sin 4t)e^{-t}] = 4 = 4A_2, \text{ or } A_2 = 1$$

$$i(t) = \underline{\underline{2 + \sin 4t e^{-t} \text{ A}}}$$

Chapter 8, Problem 27.

A branch voltage in an *RLC* circuit is described by

$$\frac{d^2v}{dt^2} + 4\frac{dv}{dt} + 8v = 24$$

If the initial conditions are $v(0) = 0 = dv(0)/dt$, find $v(t)$.

Chapter 8, Solution 27.

$$s^2 + 4s + 8 = 0 \text{ leads to } s = \frac{-4 \pm \sqrt{16 - 32}}{2} = -2 \pm j2$$

$$v(t) = V_s + (A_1 \cos 2t + A_2 \sin 2t)e^{-2t}$$

$$8V_s = 24 \text{ means that } V_s = 3$$

$$v(0) = 0 = 3 + A_1 \text{ leads to } A_1 = -3$$

$$dv/dt = -2(A_1 \cos 2t + A_2 \sin 2t)e^{-2t} + (-2A_1 \sin 2t + 2A_2 \cos 2t)e^{-2t}$$

$$0 = dv(0)/dt = -2A_1 + 2A_2 \text{ or } A_2 = A_1 = -3$$

$$v(t) = \underline{\underline{[3 - 3(\cos 2t + \sin 2t)e^{-2t}] \text{ volts}}}$$

Chapter 8, Problem 28.

A series RLC circuit is described by

$$L \frac{d^2 i}{dt^2} + R \frac{di}{dt} + \frac{i}{C} = 2$$

Find the response when $L = 0.5 \text{ H}$, $R = 4 \Omega$,
and $C = 0.2 \text{ F}$. Let $i(0) = 1$, $di(0)/dt = 0$.

Chapter 8, Solution 28.

The characteristic equation is

$$Ls^2 + Rs + \frac{1}{C} = 0 \quad \longrightarrow \quad \frac{1}{2}s^2 + 4s + \frac{1}{0.2} = 0 \quad \longrightarrow \quad s^2 + 8s + 10 = 0$$

$$s_{1,2} = \frac{-8 \pm \sqrt{64 - 40}}{2} = -6.45 \text{ and } -1.5505$$

$$i(t) = i_s + Ae^{-6.45t} + Be^{-1.5505t}$$

But $\frac{I_s}{LC} = 2 \longrightarrow I_s = \frac{2}{0.5 \times 0.2} = 20$

$$i(t) = 20 + Ae^{-6.45t} + Be^{-1.5505t}$$

$$i(0) = 1 = 20 + A + B \text{ or } A + B = -19 \quad (1)$$

$$\frac{di(t)}{dt} = -6.45Ae^{-6.45t} - 1.5505Be^{-1.5505t} \quad (2)$$

$$\text{but } \frac{di(0)}{dt} = 0 = -6.45A - 1.5505B$$

Solving (1) and (2) gives $A = 6.013$, $B = -25.013$

Hence,

$$i(t) = \underline{\underline{20 + 6.013e^{-6.45t} - 25.013e^{-1.5505t} \text{ A}}}$$

Chapter 8, Problem 29.

Solve the following differential equations subject to the specified initial conditions

(a) $d^2v/dt^2 + 4v = 12$, $v(0) = 0$, $dv(0)/dt = 2$

(b) $d^2i/dt^2 + 5 di/dt + 4i = 8$, $i(0) = -1$, $di(0)/dt = 0$

(c) $d^2v/dt^2 + 2 dv/dt + v = 3$, $v(0) = 5$, $dv(0)/dt = 1$

(d) $d^2i/dt^2 = 2 di/dt = 5i = 10$, $i(0) = 4$, $di(0)/dt = -2$

Chapter 8, Solution 29.

(a) $s^2 + 4 = 0$ which leads to $s_{1,2} = \pm j2$ (an undamped circuit)

$$v(t) = V_s + A\cos 2t + B\sin 2t$$

$$4V_s = 12 \text{ or } V_s = 3$$

$$v(0) = 0 = 3 + A \text{ or } A = -3$$

$$dv/dt = -2A\sin 2t + 2B\cos 2t$$

$$dv(0)/dt = 2 = 2B \text{ or } B = 1, \text{ therefore } v(t) = \underline{\underline{(3 - 3\cos 2t + \sin 2t) V}}$$

(b) $s^2 + 5s + 4 = 0$ which leads to $s_{1,2} = -1, -4$

$$i(t) = (I_s + Ae^{-t} + Be^{-4t})$$

$$4I_s = 8 \text{ or } I_s = 2$$

$$i(0) = -1 = 2 + A + B, \text{ or } A + B = -3 \quad (1)$$

$$di/dt = -Ae^{-t} - 4Be^{-4t}$$

$$di(0)/dt = 0 = -A - 4B, \text{ or } B = -A/4 \quad (2)$$

From (1) and (2) we get $A = -4$ and $B = 1$

$$i(t) = \underline{\underline{(2 - 4e^{-t} + e^{-4t}) A}}$$

$$(c) \quad s^2 + 2s + 1 = 0, \quad s_{1,2} = -1, -1$$

$$v(t) = [V_s + (A + Bt)e^{-t}], \quad V_s = 3.$$

$$v(0) = 5 = 3 + A \quad \text{or} \quad A = 2$$

$$dv/dt = [-(A + Bt)e^{-t}] + [Be^{-t}]$$

$$dv(0)/dt = -A + B = 1 \quad \text{or} \quad B = 2 + 1 = 3$$

$$v(t) = \underline{\underline{[3 + (2 + 3t)e^{-t}] V}}$$

$$(d) \quad s^2 + 2s + 5 = 0, \quad s_{1,2} = -1 + j2, -1 - j2$$

$$i(t) = [I_s + (A\cos 2t + B\sin 2t)e^{-t}], \quad \text{where } 5I_s = 10 \quad \text{or} \quad I_s = 2$$

$$i(0) = 4 = 2 + A \quad \text{or} \quad A = 2$$

$$di/dt = [-(A\cos 2t + B\sin 2t)e^{-t}] + [(-2A\sin 2t + 2B\cos 2t)e^{-t}]$$

$$di(0)/dt = -2 = -A + 2B \quad \text{or} \quad B = 0$$

$$i(t) = \underline{\underline{[2 + (2\cos 2t)e^{-t}] A}}$$

Chapter 8, Problem 30.

The step responses of a series RLC circuit are

$$v_C = 40 - 10e^{-2000t} - 10e^{-4000t} \text{ V}, \quad t > 0$$

$$i_L(t) = 3e^{-2000t} + 6e^{-4000t} \text{ mA}, \quad t > 0$$

(a) Find C . (b) Determine what type of damping is exhibited by the circuit.

Chapter 8, Solution 30.

$$(a) \quad i_L(t) = i_C(t) = C \frac{dv_C}{dt} \quad (1)$$

$$\frac{dv_C}{dt} = 2000 \times 10e^{-2000t} + 4000 \times 10e^{-4000t} = 2 \times 10^4 (e^{-2000t} + 2e^{-4000t}) \quad (2)$$

$$\text{But } i_L(t) = 3[e^{-2000t} + 2e^{-4000t}] \times 10^{-3} \quad (3)$$

Substituting (2) and (3) into (1), we get

$$2 \times 10^4 \times C = 3 \times 10^{-3} \quad \longrightarrow \quad C = 1.5 \times 10^{-7} = \underline{150 \text{ nF}}$$

(b) Since $s_1 = -2000$ and $s_2 = -4000$ are real and negative, it is an **overdamped** case.

Chapter 8, Problem 31.



Consider the circuit in Fig. 8.79. Find $v_L(0^+)$ and $v_C(0^+)$

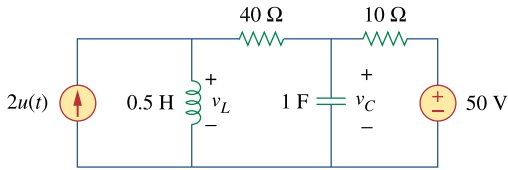

Figure 8.79
For Prob. 8.31.

Chapter 8, Solution 31.

For $t = 0^-$, we have the equivalent circuit in Figure (a). For $t = 0^+$, the equivalent circuit is shown in Figure (b). By KVL,

$$v(0^+) = v(0^-) = 40, \quad i(0^+) = i(0^-) = 1$$

By KCL, $2 = i(0^+) + i_1 = 1 + i_1$ which leads to $i_1 = 1$. By KVL, $-v_L + 40i_1 + v(0^+) = 0$ which leads to $v_L(0^+) = 40 \times 1 + 40 = 80$

$$v_L(0^+) = \underline{80 \text{ V}}, \quad v_C(0^+) = \underline{40 \text{ V}}$$

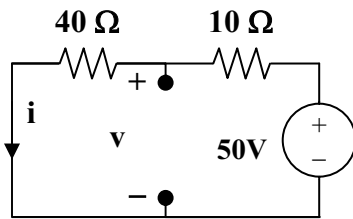

(a)

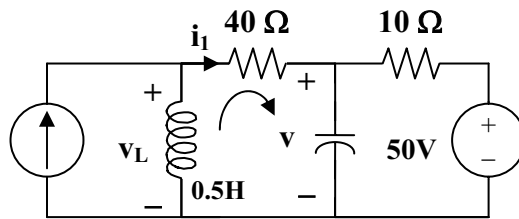

(b)

Chapter 8, Problem 32.



For the circuit in Fig. 8.80, find $v(t)$ for $t > 0$.

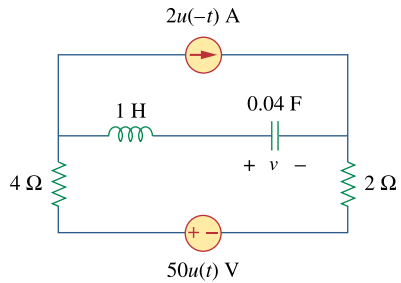
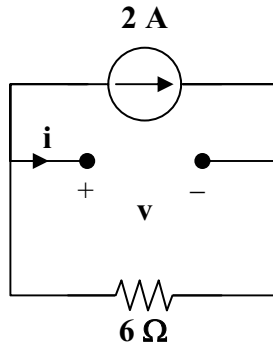

Figure 8.80

For Prob. 8.32.

Chapter 8, Solution 32.

For $t = 0^-$, the equivalent circuit is shown below.



$$i(0^-) = 0, v(0^-) = -2 \times 6 = -12\text{V}$$

For $t > 0$, we have a series RLC circuit with a step input.

$$\alpha = R/(2L) = 6/2 = 3, \omega_o = 1/\sqrt{LC} = 1/\sqrt{0.04}$$

$$s = -3 \pm \sqrt{9 - 25} = -3 \pm j4$$

$$\text{Thus, } v(t) = V_f + [(A\cos 4t + B\sin 4t)e^{-3t}]$$

where $V_f = \text{final capacitor voltage} = 50\text{ V}$

$$v(t) = 50 + [(A\cos 4t + B\sin 4t)e^{-3t}]$$

$$v(0) = -12 = 50 + A \text{ which gives } A = -62$$

$$i(0) = 0 = Cdv(0)/dt$$

$$dv/dt = [-3(A\cos 4t + B\sin 4t)e^{-3t}] + [4(-A\sin 4t + B\cos 4t)e^{-3t}]$$

$$0 = dv(0)/dt = -3A + 4B \text{ or } B = (3/4)A = -46.5$$

$$v(t) = \underline{\underline{\{50 + [(-62\cos 4t - 46.5\sin 4t)e^{-3t}]\} \text{ V}}}$$

Chapter 8, Problem 33.



Find $v(t)$ for $t > 0$ in the circuit of Fig. 8.81.

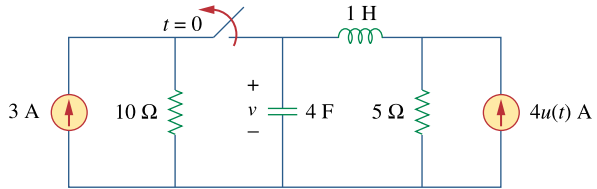
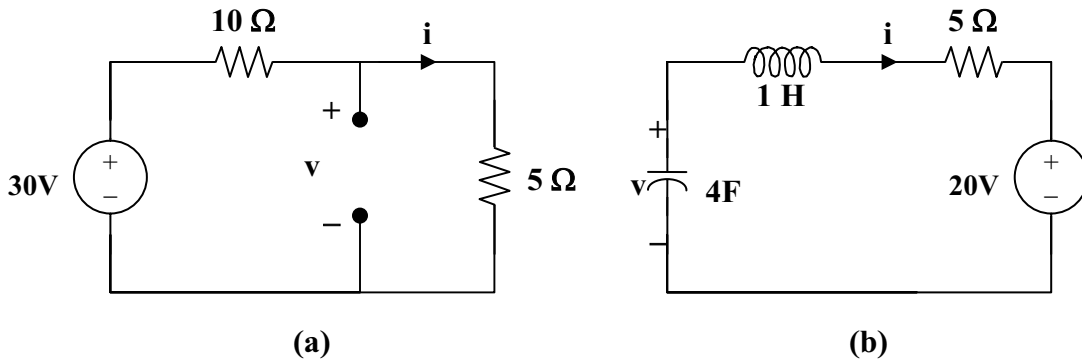

Figure 8.81
For Prob. 8.33.

Chapter 8, Solution 33.

We may transform the current sources to voltage sources. For $t = 0^-$, the equivalent circuit is shown in Figure (a).



$$i(0) = 30/15 = 2 \text{ A}, \quad v(0) = 5 \times 30/15 = 10 \text{ V}$$

For $t > 0$, we have a series RLC circuit, shown in (b).

$$\alpha = R/(2L) = 5/2 = 2.5$$

$$\omega_0 = 1/\sqrt{LC} = 1/\sqrt{4} = 0.5, \quad \text{clearly } \alpha > \omega_0 \text{ (overdamped response)}$$

$$s_{1,2} = -\alpha \pm \sqrt{\alpha^2 - \omega_0^2} = -2.5 \pm \sqrt{6.25 - 0.25} = -4.95, -0.0505$$

$$v(t) = V_s + [A_1 e^{-4.95t} + A_2 e^{-0.0505t}], \quad V_s = 20.$$

$$\begin{aligned} v(0) = 10 &= 20 + A_1 + A_2 \quad \text{or} \\ A_2 &= -10 - A_1 \end{aligned} \tag{1}$$

$$i(0) = C dv(0)/dt \quad \text{or} \quad dv(0)/dt = 2/4 = 1/2$$

Hence, $0.5 = -4.95A_1 - 0.0505A_2$ (2)

From (1) and (2), $0.5 = -4.95A_1 + 0.505(10 + A_1)$ or $-4.445A_1 = -0.005$

$$A_1 = 0.001125, \quad A_2 = -10.001$$

$$v(t) = \underline{\underline{20 + 0.001125e^{-4.95t} - 10.001e^{-0.05t} \text{ V}}}$$

Chapter 8, Problem 34.

Calculate $i(t)$ for $t > 0$ in the circuit of Fig. 8.82.

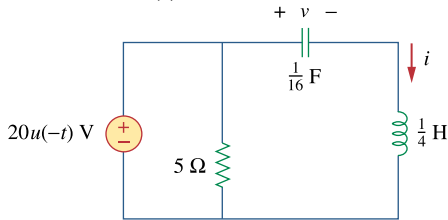

Figure 8.82

For Prob. 8.34.

Chapter 8, Solution 34.

Before $t = 0$, the capacitor acts like an open circuit while the inductor behaves like a short circuit.

$$i(0) = 0, v(0) = 20 \text{ V}$$

For $t > 0$, the LC circuit is disconnected from the voltage source as shown below.

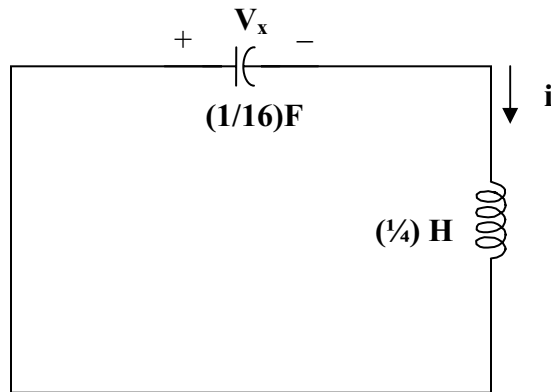

This is a lossless, source-free, series RLC circuit.

$$\alpha = R/(2L) = 0, \omega_0 = 1/\sqrt{LC} = 1/\sqrt{\frac{1}{16} + \frac{1}{4}} = 8, s = \pm j8$$

Since α is less than ω_0 , we have an underdamped response. Therefore,

$$i(t) = A_1 \cos 8t + A_2 \sin 8t \text{ where } i(0) = 0 = A_1$$

$$di(0)/dt = (1/L)v_L(0) = -(1/L)v(0) = -4 \times 20 = -80$$

However, $di/dt = 8A_2 \cos 8t$, thus, $di(0)/dt = -80 = 8A_2$ which leads to $A_2 = -10$

Now we have $i(t) = \underline{\underline{-10 \sin 8t \text{ A}}}$

PROPRIETARY MATERIAL. © 2007 The McGraw-Hill Companies, Inc. All rights reserved. No part of this Manual may be displayed, reproduced or distributed in any form or by any means, without the prior written permission of the publisher, or used beyond the limited distribution to teachers and educators permitted by McGraw-Hill for their individual course preparation. If you are a student using this Manual, you are using it without permission.

Chapter 8, Problem 35.

Determine $v(t)$ for $t > 0$ in the circuit of Fig. 8.83.

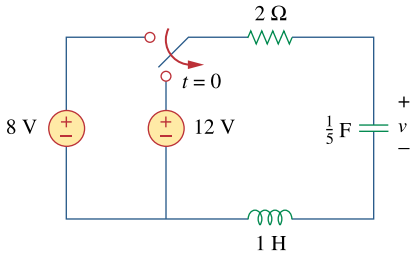

Figure 8.83
For Prob. 8.35.

Chapter 8, Solution 35.

$$\text{At } t = 0^-, i_L(0) = 0, v(0) = v_C(0) = 8 \text{ V}$$

For $t > 0$, we have a series RLC circuit with a step input.

$$\alpha = R/(2L) = 2/2 = 1, \omega_o = 1/\sqrt{LC} = 1/\sqrt{1/5} = \sqrt{5}$$

$$s_{1,2} = -\alpha \pm \sqrt{\alpha^2 - \omega_o^2} = -1 \pm j2$$

$$v(t) = V_s + [(A\cos 2t + B\sin 2t)e^{-t}], V_s = 12.$$

$$v(0) = 8 = 12 + A \text{ or } A = -4, i(0) = Cdv(0)/dt = 0.$$

$$\text{But } dv/dt = [-(A\cos 2t + B\sin 2t)e^{-t}] + [2(-A\sin 2t + B\cos 2t)e^{-t}]$$

$$0 = dv(0)/dt = -A + 2B \text{ or } 2B = A = -4 \text{ and } B = -2$$

$$v(t) = \underline{\underline{\{12 - (4\cos 2t + 2\sin 2t)e^{-t}\} \text{ V.}}}$$

Chapter 8, Problem 36.

Obtain $v(t)$ and $i(t)$ for $t > 0$ in the circuit of Fig. 8.84.

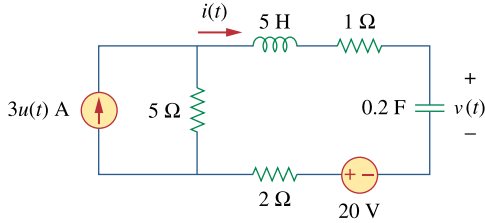
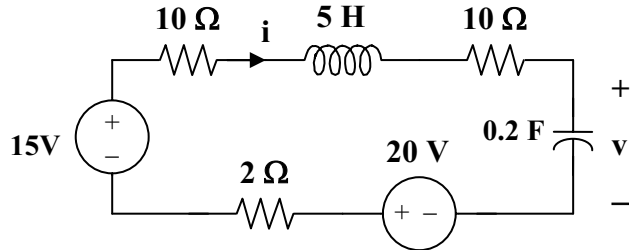

Figure 8.84
For Prob. 8.36.

Chapter 8, Solution 36.

For $t = 0^-$, $3u(t) = 0$. Thus, $i(0) = 0$, and $v(0) = 20$ V.
For $t > 0$, we have the series RLC circuit shown below.



$$\alpha = R/(2L) = (2 + 5 + 1)/(2 \times 5) = 0.8$$

$$\omega_0 = 1/\sqrt{LC} = 1/\sqrt{5 \times 0.2} = 1$$

$$s_{1,2} = -\alpha \pm \sqrt{\alpha^2 - \omega_0^2} = -0.8 \pm j0.6$$

$$v(t) = V_s + [(A \cos 0.6t + B \sin 0.6t)e^{-0.8t}]$$

$$V_s = 15 + 20 = 35\text{V and } v(0) = 20 = 35 + A \text{ or } A = -15$$

$$i(0) = Cdv(0)/dt = 0$$

$$\text{But } dv/dt = [-0.8(A \cos 0.6t + B \sin 0.6t)e^{-0.8t}] + [0.6(-A \sin 0.6t + B \cos 0.6t)e^{-0.8t}]$$

$$0 = dv(0)/dt = -0.8A + 0.6B \text{ which leads to } B = 0.8 \times (-15)/0.6 = -20$$

$$v(t) = \underline{\underline{\{35 - [(15 \cos 0.6t + 20 \sin 0.6t)e^{-0.8t}]\} \text{ V}}}$$

$$i = Cdv/dt = 0.2 \{ [0.8(15 \cos 0.6t + 20 \sin 0.6t)e^{-0.8t}] + [0.6(15 \sin 0.6t - 20 \cos 0.6t)e^{-0.8t}] \}$$

$$i(t) = \underline{\underline{\{5 \sin 0.6t\} e^{-0.8t} \text{ A}}}$$

Chapter 8, Problem 37.

* For the network in Fig. 8.85, solve for $i(t)$ for $t > 0$.

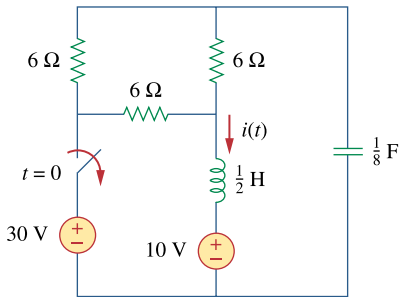
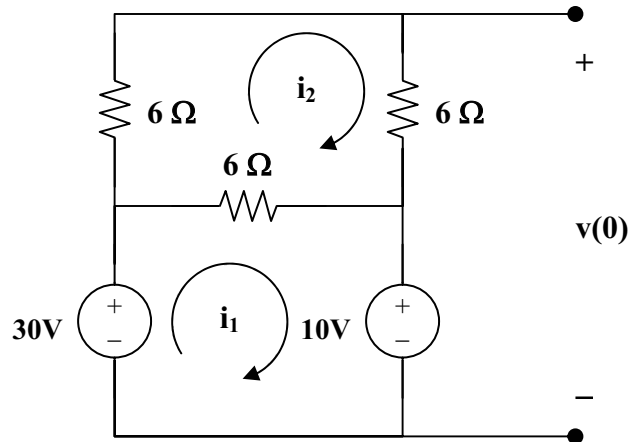

Figure 8.85
For Prob. 8.37.

* An asterisk indicates a challenging problem.

Chapter 8, Solution 37.

For $t = 0^-$, the equivalent circuit is shown below.



$$18i_2 - 6i_1 = 0 \text{ or } i_1 = 3i_2 \quad (1)$$

$$-30 + 6(i_1 - i_2) + 10 = 0 \text{ or } i_1 - i_2 = 10/3 \quad (2)$$

From (1) and (2). $i_1 = 5, i_2 = 5/3$

$$i(0) = i_1 = 5\text{A}$$

$$-10 - 6i_2 + v(0) = 0$$

$$v(0) = 10 + 6 \times 5/3 = 20$$

For $t > 0$, we have a series RLC circuit.

$$R = 6 \parallel 12 = 4$$

$$\omega_o = 1/\sqrt{LC} = 1/\sqrt{(1/2)(1/8)} = 4$$

$$\alpha = R/(2L) = (4)/(2 \times (1/2)) = 4$$

$\alpha = \omega_o$, therefore the circuit is critically damped

$$v(t) = V_s + [(A + Bt)e^{-4t}], \text{ and } V_s = 10$$

$$v(0) = 20 = 10 + A, \text{ or } A = 10$$

$$i_C = Cdv/dt = C[-4(10 + Bt)e^{-4t}] + C[(B)e^{-4t}]$$

To find $i_C(0)$ we need to look at the circuit right after the switch is opened. At this time, the current through the inductor forces that part of the circuit to act like a current source and the capacitor acts like a voltage source. This produces the circuit shown below. Clearly, $i_C(0^+)$ must equal $-i_L(0) = -5A$.

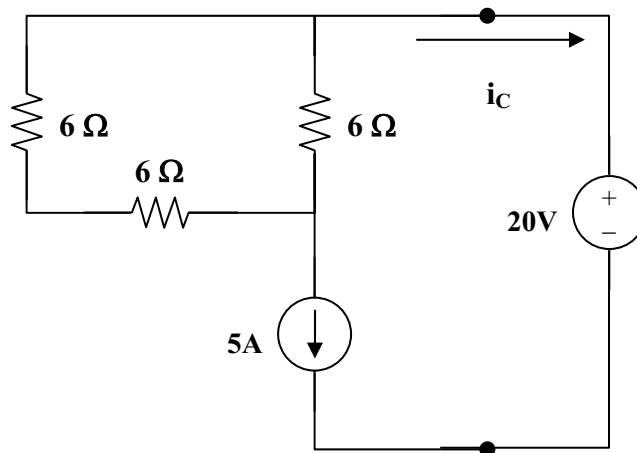

$$i_C(0) = -5 = C(-40 + B) \text{ which leads to } -40 = -40 + B \text{ or } B = 0$$

$$i_C = Cdv/dt = (1/8)[-4(10 + 0t)e^{-4t}] + (1/8)[(0)e^{-4t}]$$

$$i_C(t) = [-(1/2)(10)e^{-4t}]$$

$$i(t) = -i_C(t) = \underline{\underline{5e^{-4t} \text{ A}}}$$

PROPRIETARY MATERIAL. © 2007 The McGraw-Hill Companies, Inc. All rights reserved. No part of this Manual may be displayed, reproduced or distributed in any form or by any means, without the prior written permission of the publisher, or used beyond the limited distribution to teachers and educators permitted by McGraw-Hill for their individual course preparation. If you are a student using this Manual, you are using it without permission.

Chapter 8, Problem 38.

Refer to the circuit in Fig. 8.86. Calculate $i(t)$ for $t > 0$

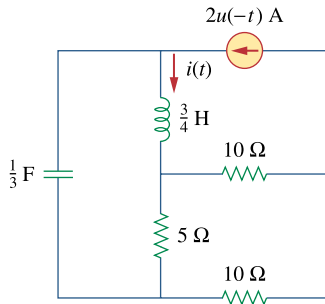
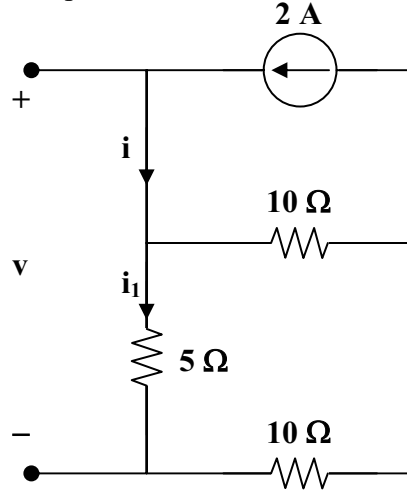

Figure 8.86
For Prob. 8.38.

Chapter 8, Solution 38.

At $t = 0^-$, the equivalent circuit is as shown.



$$i(0) = 2\text{A}, \quad i_1(0) = 10(2)/(10 + 15) = 0.8 \text{ A}$$

$$v(0) = 5i_1(0) = 4\text{V}$$

For $t > 0$, we have a source-free series RLC circuit.

$$R = 5 \parallel (10 + 10) = 4 \text{ ohms}$$

$$\omega_0 = 1/\sqrt{LC} = 1/\sqrt{(1/3)(3/4)} = 2$$

$$\alpha = R/(2L) = (4)/(2 \times (3/4)) = 8/3$$

$$s_{1,2} = -\alpha \pm \sqrt{\alpha^2 - \omega_0^2} = -4.431, -0.903$$

$$i(t) = [Ae^{-4.431t} + Be^{-0.903t}]$$

$$i(0) = A + B = 2 \tag{1}$$

$$di(0)/dt = (1/L)[-Ri(0) + v(0)] = (4/3)(-4 \times 2 + 4) = -16/3 = -5.333$$

$$\text{Hence, } -5.333 = -4.431A - 0.903B \tag{2}$$

From (1) and (2), $A = 1$ and $B = 1$.

$$i(t) = \underline{[e^{-4.431t} + e^{-0.903t}] \text{ A}}$$

Chapter 8, Problem 39.

Determine $v(t)$ for $t > 0$ in the circuit of Fig. 8.87.

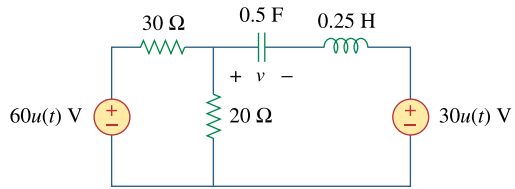
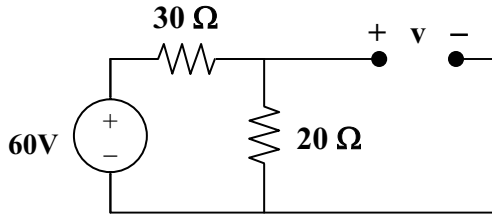

Figure 8.87
For Prob. 8.39.

Chapter 8, Solution 39.

For $t = 0^-$, the equivalent circuit is shown in Figure (a). Where $60u(-t) = 60$ and $30u(t) = 0$.



(a)

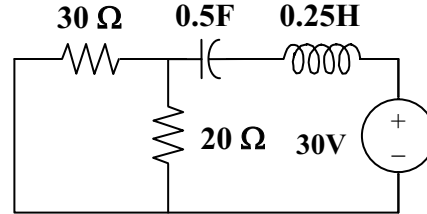

(b)

$$v(0) = (20/50)(60) = 24 \text{ and } i(0) = 0$$

For $t > 0$, the circuit is shown in Figure (b).

$$R = 20 \parallel 30 = 12 \text{ ohms}$$

$$\omega_0 = 1/\sqrt{LC} = 1/\sqrt{(1/2)(1/4)} = \sqrt{8}$$

$$\alpha = R/(2L) = (12)/(0.5) = 24$$

Since $\alpha > \omega_0$, we have an overdamped response.

$$s_{1,2} = -\alpha \pm \sqrt{\alpha^2 - \omega_0^2} = -47.833, -0.167$$

Thus,

$$v(t) = V_s + [Ae^{-47.833t} + Be^{-0.167t}], \quad V_s = 30$$

$$v(0) = 24 = 30 + A + B \text{ or } -6 = A + B \tag{1}$$

$$i(0) = Cdv(0)/dt = 0$$

$$\text{But, } dv(0)/dt = -47.833A - 0.167B = 0$$

$$B = -286.43A \tag{2}$$

From (1) and (2), $A = 0.021$ and $B = -6.021$

$$v(t) = \underline{\underline{30 + [0.021e^{-47.833t} - 6.021e^{-0.167t}] \text{ V}}}$$

Chapter 8, Problem 40.



The switch in the circuit of Fig. 8.88 is moved from position a to b at $t = 0$. Determine $i(t)$ for $t > 0$.

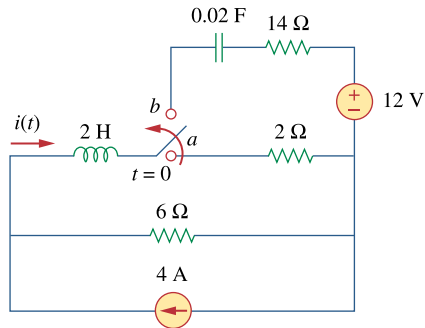
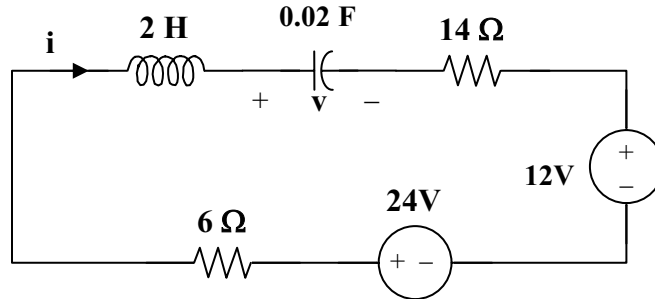

Figure 8.88
For Prob. 8.40.

Chapter 8, Solution 40.

At $t = 0^-$, $v_C(0) = 0$ and $i_L(0) = i(0) = (6/(6 + 2))4 = 3\text{A}$

For $t > 0$, we have a series RLC circuit with a step input as shown below.



$$\omega_o = 1/\sqrt{LC} = 1/\sqrt{2 \times 0.02} = 5$$

$$\alpha = R/(2L) = (6 + 14)/(2 \times 2) = 5$$

Since $\alpha = \omega_o$, we have a critically damped response.

$$v(t) = V_s + [(A + Bt)e^{-5t}], \quad V_s = 24 - 12 = 12\text{V}$$

$$v(0) = 0 = 12 + A \quad \text{or} \quad A = -12$$

$$i = Cdv/dt = C\{[Be^{-5t}] + [-5(A + Bt)e^{-5t}]\}$$

$$i(0) = 3 = C[-5A + B] = 0.02[60 + B] \quad \text{or} \quad B = 90$$

$$\text{Thus, } i(t) = 0.02\{[90e^{-5t}] + [-5(-12 + 90t)e^{-5t}]\}$$

$$i(t) = \underline{\underline{\{3 - 9t\}e^{-5t} \text{ A}}}$$

Chapter 8, Problem 41.

* For the network in Fig. 8.89, find $i(t)$ for $t > 0$.

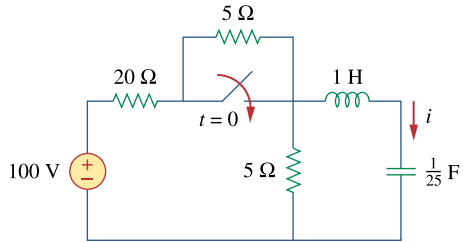

Figure 8.89
For Prob. 8.41.

Chapter 8, Solution 41.

At $t = 0^-$, the switch is open. $i(0) = 0$, and

$$v(0) = 5 \times 100 / (20 + 5 + 5) = 50/3$$

For $t > 0$, we have a series RLC circuit shown in Figure (a). After source transformation, it becomes that shown in Figure (b).

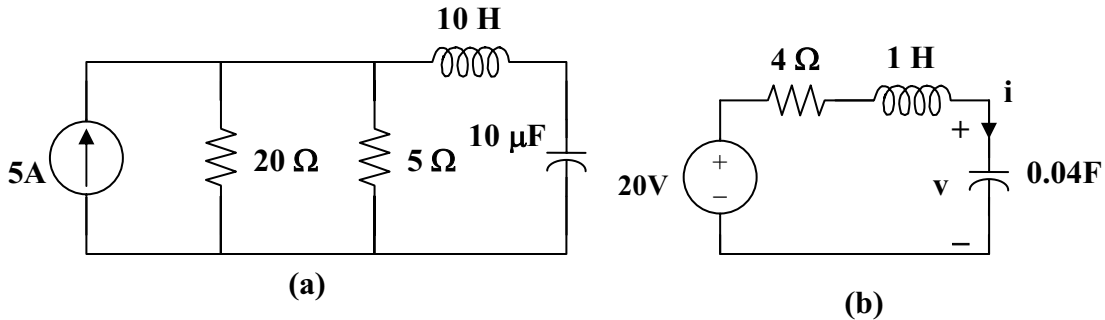

$$\omega_o = 1/\sqrt{LC} = 1/\sqrt{1 \times 1/25} = 5$$

$$\alpha = R/(2L) = (4)/(2 \times 1) = 2$$

$$s_{1,2} = -\alpha \pm \sqrt{\alpha^2 - \omega_o^2} = -2 \pm j4.583$$

Thus,
$$v(t) = V_s + [(A \cos \omega_d t + B \sin \omega_d t) e^{-2t}]$$

where $\omega_d = 4.583$ and $V_s = 20$

$$v(0) = 50/3 = 20 + A \text{ or } A = -10/3$$

$$i(t) = C dv/dt = C(-2) [(A \cos \omega_d t + B \sin \omega_d t) e^{-2t}] + C \omega_d [(-A \sin \omega_d t + B \cos \omega_d t) e^{-2t}]$$

$$i(0) = 0 = -2A + \omega_d B$$

$$B = 2A/\omega_d = -20/(3 \times 4.583) = -1.455$$

$$i(t) = C \{ [(0 \cos \omega_d t + (-2B - \omega_d A) \sin \omega_d t)] e^{-2t} \}$$

$$= (1/25) \{ [(2.91 + 15.2767) \sin \omega_d t] e^{-2t} \}$$

$$i(t) = \underline{\underline{\{0.7275 \sin(4.583t) e^{-2t}\} \text{ A}}}$$

Chapter 8, Problem 42.

* Given the network in Fig. 8.90, find $v(t)$ for $t > 0$.

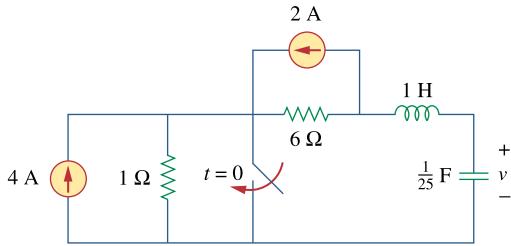
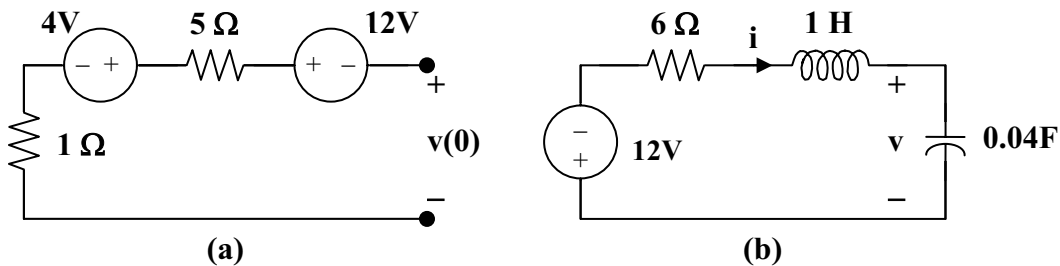

Figure 8.90
For Prob. 8.42.

Chapter 8, Solution 42.

For $t = 0^-$, we have the equivalent circuit as shown in Figure (a).

$$i(0^-) = i(0^+) = 0, \text{ and } v(0^-) = 4 - 12 = -8\text{V}$$



For $t > 0$, the circuit becomes that shown in Figure (b) after source transformation.

$$\omega_0 = 1/\sqrt{LC} = 1/\sqrt{1 \times 1/25} = 5$$

$$\alpha = R/(2L) = (6)/(2) = 3$$

$$s_{1,2} = -\alpha \pm \sqrt{\alpha^2 - \omega_0^2} = -3 \pm j4$$

Thus, $v(t) = V_s + [(A \cos 4t + B \sin 4t)e^{-3t}]$, $V_s = -12$

$$v(0) = -8 = -12 + A \text{ or } A = 4$$

$$i = Cdv/dt, \text{ or } i/C = dv/dt = [-3(A \cos 4t + B \sin 4t)e^{-3t}] + [4(-A \sin 4t + B \cos 4t)e^{-3t}]$$

$$i(0) = -3A + 4B \text{ or } B = 3$$

$$v(t) = \{-12 + [(4 \cos 4t + 3 \sin 4t)e^{-3t}]\} \text{ A}$$

Chapter 8, Problem 43.

The switch in Fig. 8.91 is opened at $t = 0$ after the circuit has reached steady state. Choose R and C such that $\alpha = 8 \text{ Np/s}$ and $\omega_d = 30 \text{ rad/s}$.

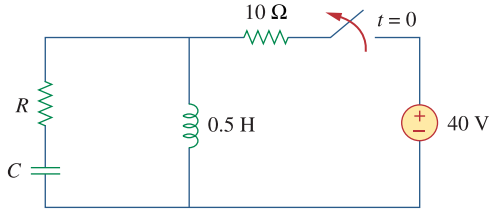

Figure 8.91

For Prob. 8.43.

Chapter 8, Solution 43.

For $t > 0$, we have a source-free series RLC circuit.

$$\alpha = \frac{R}{2L} \longrightarrow R = 2\alpha L = 2 \times 8 \times 0.5 = \underline{8\Omega}$$

$$\omega_d = \sqrt{\omega_o^2 - \alpha^2} = 30 \longrightarrow \omega_o = \sqrt{900 - 64} = \sqrt{836}$$

$$\omega_o = \frac{1}{\sqrt{LC}} \longrightarrow C = \frac{1}{\omega_o^2 L} = \frac{1}{836 \times 0.5} = \underline{2.392 \text{ mF}}$$

Chapter 8, Problem 44.

A series RLC circuit has the following parameters: $R = 1 \text{ k}\Omega$, $L = 1 \text{ H}$, and $C = 10 \text{ nF}$. What type of damping does this circuit exhibit?

Chapter 8, Solution 44.

$$\alpha = \frac{R}{2L} = \frac{1000}{2 \times 1} = 500, \quad \omega_o = \frac{1}{\sqrt{LC}} = \frac{1}{\sqrt{100 \times 10^{-9}}} = 10^4$$

$$\omega_o > \alpha \longrightarrow \underline{\text{underdamped.}}$$

Chapter 8, Problem 45.

In the circuit of Fig. 8.92, find $v(t)$ and $i(t)$ for $t > 0$. Assume $v(0) = 0$ V and $i(0) = 1$ A.

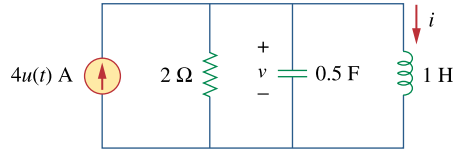

Figure 8.92
For Prob. 8.45.

Chapter 8, Solution 45.

$$\omega_o = 1/\sqrt{LC} = 1/\sqrt{1 \times 0.5} = \sqrt{2}$$

$$\alpha = 1/(2RC) = (1)/(2 \times 2 \times 0.5) = 0.5$$

Since $\alpha < \omega_o$, we have an underdamped response.

$$s_{1,2} = -\alpha \pm \sqrt{\omega_o^2 - \alpha^2} = -0.5 \pm j1.3229$$

Thus,
$$i(t) = I_s + [(A \cos 1.3229t + B \sin 1.3229t)e^{-0.5t}], \quad I_s = 4$$

$$i(0) = 1 = 4 + A \quad \text{or} \quad A = -3$$

$$v = v_C = v_L = L di(0)/dt = 0$$

$$di/dt = [1.3229(-A \sin 1.3229t + B \cos 1.3229t)e^{-0.5t}] + [-0.5(A \cos 1.3229t + B \sin 1.3229t)e^{-0.5t}]$$

$$di(0)/dt = 0 = 1.3229B - 0.5A \quad \text{or} \quad B = 0.5(-3)/1.3229 = -1.1339$$

Thus,
$$i(t) = \underline{\{4 - [(3 \cos 1.3229t + 1.1339 \sin 1.3229t)e^{-t/2}]\} \text{ A}}$$

To find $v(t)$ we use $v(t) = v_L(t) = L di(t)/dt$.

From above,

$$di/dt = [1.3229(-A \sin 1.3229t + B \cos 1.3229t)e^{-0.5t}] + [-0.5(A \cos 1.323t + B \sin 1.323t)e^{-0.5t}]$$

Thus,

$$\begin{aligned} v(t) &= L di/dt = [1.323(-A \sin 1.323t + B \cos 1.323t)e^{-0.5t}] + \\ &\quad [-0.5(A \cos 1.323t + B \sin 1.323t)e^{-0.5t}] \\ &= [1.3229(3 \sin 1.3229t - 1.1339 \cos 1.3229t)e^{-0.5t}] + \\ &\quad [(1.5 \cos 1.3229t + 0.5670 \sin 1.3229t)e^{-0.5t}] \end{aligned}$$

$$\begin{aligned} v(t) &= [(-0 \cos 1.323t + 4.536 \sin 1.323t)e^{-0.5t}] \text{ V} \\ &= \underline{\{4.536 \sin 1.323t\} \text{ V}} \end{aligned}$$

Please note that the term in front of the cos calculates out to -3.631×10^{-5} which is zero for all practical purposes when considering the rounding errors of the terms used to calculate it.

Chapter 8, Problem 46.

Find $i(t)$ for $t > 0$ in the circuit of Fig. 8.93.

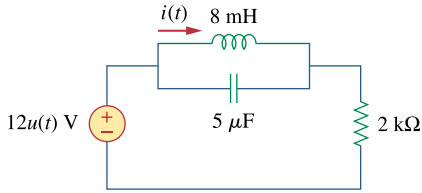

Figure 8.93

For Prob. 8.46.

Chapter 8, Solution 46.

For $t = 0^-$, $u(t) = 0$, so that $v(0) = 0$ and $i(0) = 0$.

For $t > 0$, we have a parallel RLC circuit with a step input, as shown below.

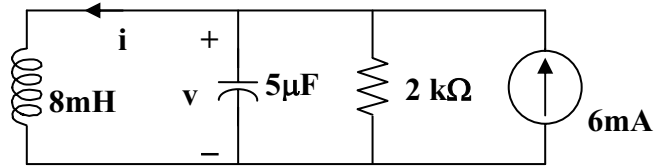

$$\alpha = 1/(2RC) = (1)/(2 \times 2 \times 10^3 \times 5 \times 10^{-6}) = 50$$

$$\omega_0 = 1/\sqrt{LC} = 1/\sqrt{8 \times 10^{-3} \times 5 \times 10^{-6}} = 5,000$$

Since $\alpha < \omega_0$, we have an underdamped response.

$$s_{1,2} = -\alpha \pm \sqrt{\alpha^2 - \omega_0^2} \cong -50 \pm j5,000$$

Thus,
$$i(t) = I_s + [(A \cos 5,000t + B \sin 5,000t)e^{-50t}], \quad I_s = 6 \text{ mA}$$

$$i(0) = 0 = 6 + A \quad \text{or} \quad A = -6 \text{ mA}$$

$$v(0) = 0 = L di(0)/dt$$

$$di/dt = [5,000(-A \sin 5,000t + B \cos 5,000t)e^{-50t}] + [-50(A \cos 5,000t + B \sin 5,000t)e^{-50t}]$$

$$di(0)/dt = 0 = 5,000B - 50A \quad \text{or} \quad B = 0.01(-6) = -0.06 \text{ mA}$$

Thus,
$$i(t) = \underline{\underline{\{6 - [(6 \cos 5,000t + 0.06 \sin 5,000t)e^{-50t}]\} \text{ mA}}}$$

Chapter 8, Problem 47.

Find the output voltage $v_o(t)$ in the circuit of Fig. 8.94.

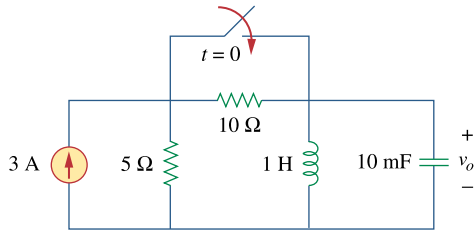

Figure 8.94
For Prob. 8.47.

Chapter 8, Solution 47.

$$\text{At } t = 0^-, \text{ we obtain, } i_L(0) = 3 \times 5 / (10 + 5) = 1 \text{ A}$$

$$\text{and } v_o(0) = 0.$$

For $t > 0$, the 10-ohm resistor is short-circuited and we have a parallel RLC circuit with a step input.

$$\alpha = 1/(2RC) = (1)/(2 \times 5 \times 0.01) = 10$$

$$\omega_o = 1/\sqrt{LC} = 1/\sqrt{1 \times 0.01} = 10$$

Since $\alpha = \omega_o$, we have a critically damped response.

$$s_{1,2} = -10$$

Thus,
$$i(t) = I_s + [(A + Bt)e^{-10t}], \quad I_s = 3$$

$$i(0) = 1 = 3 + A \quad \text{or } A = -2$$

$$v_o = L di/dt = [Be^{-10t}] + [-10(A + Bt)e^{-10t}]$$

$$v_o(0) = 0 = B - 10A \quad \text{or } B = -20$$

$$\text{Thus, } v_o(t) = \underline{\underline{(200te^{-10t}) \text{ V}}}$$

Chapter 8, Problem 48.

Given the circuit in Fig. 8.95, find $i(t)$ and $v(t)$ for $t > 0$.

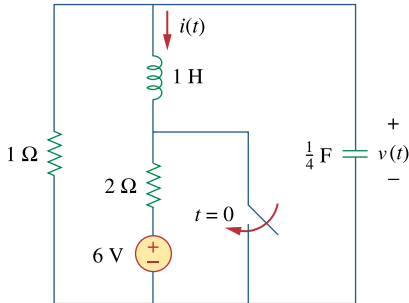

Figure 8.95
For Prob. 8.48.

Chapter 8, Solution 48.

For $t = 0^-$, we obtain $i(0) = -6/(1 + 2) = -2$ and $v(0) = 2 \times 1 = 2$.

For $t > 0$, the voltage is short-circuited and we have a source-free parallel RLC circuit.

$$\alpha = 1/(2RC) = (1)/(2 \times 1 \times 0.25) = 2$$

$$\omega_0 = 1/\sqrt{LC} = 1/\sqrt{1 \times 0.25} = 2$$

Since $\alpha = \omega_0$, we have a critically damped response.

$$s_{1,2} = -2$$

Thus, $i(t) = [(A + Bt)e^{-2t}]$, $i(0) = -2 = A$

$$v = Ldi/dt = [Be^{-2t}] + [-2(-2 + Bt)e^{-2t}]$$

$$v_0(0) = 2 = B + 4 \text{ or } B = -2$$

$$\text{Thus, } i(t) = \underline{[-2 - 2t]e^{-2t}} \text{ A}$$

$$\text{and } v(t) = \underline{[2 + 4t]e^{-2t}} \text{ V}$$

Chapter 8, Problem 49.

Determine $i(t)$ for $t > 0$ in the circuit of Fig. 8.96.

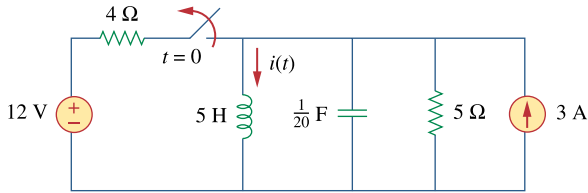

Figure 8.96
For Prob. 8.49.

Chapter 8, Solution 49.

$$\text{For } t = 0^-, i(0) = 3 + 12/4 = 6 \text{ and } v(0) = 0.$$

For $t > 0$, we have a parallel RLC circuit with a step input.

$$\alpha = 1/(2RC) = (1)/(2 \times 5 \times 0.05) = 2$$

$$\omega_o = 1/\sqrt{LC} = 1/\sqrt{5 \times 0.05} = 2$$

Since $\alpha = \omega_o$, we have a critically damped response.

$$s_{1,2} = -2$$

Thus,
$$i(t) = I_s + [(A + Bt)e^{-2t}], \quad I_s = 3$$

$$i(0) = 6 = 3 + A \text{ or } A = 3$$

$$v = Ldi/dt \text{ or } v/L = di/dt = [Be^{-2t}] + [-2(A + Bt)e^{-2t}]$$

$$v(0)/L = 0 = di(0)/dt = B - 2 \times 3 \text{ or } B = 6$$

$$\text{Thus, } i(t) = \underline{\underline{\{3 + (3 + 6t)e^{-2t}\} \text{ A}}}$$

Chapter 8, Problem 50.

For the circuit in Fig. 8.97, find $i(t)$ for $t > 0$.

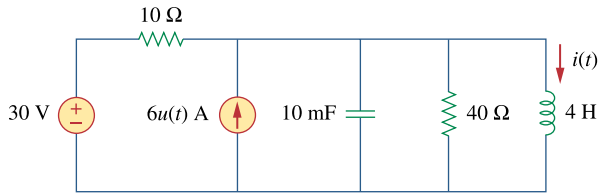

Figure 8.97

For Prob. 8.50.

Chapter 8, Solution 50.

For $t = 0^-$, $4u(t) = 0$, $v(0) = 0$, and $i(0) = 30/10 = 3\text{A}$.

For $t > 0$, we have a parallel RLC circuit.

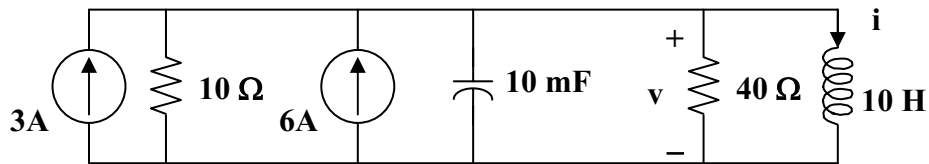

$$I_s = 3 + 6 = 9\text{A} \text{ and } R = 10 \parallel 40 = 8 \text{ ohms}$$

$$\alpha = 1/(2RC) = (1)/(2 \times 8 \times 0.01) = 25/4 = 6.25$$

$$\omega_o = 1/\sqrt{LC} = 1/\sqrt{4 \times 0.01} = 5$$

Since $\alpha > \omega_o$, we have an overdamped response.

$$s_{1,2} = -\alpha \pm \sqrt{\alpha^2 - \omega_o^2} = -10, -2.5$$

Thus,

$$i(t) = I_s + [Ae^{-10t}] + [Be^{-2.5t}], \quad I_s = 9$$

$$i(0) = 3 = 9 + A + B \text{ or } A + B = -6$$

$$di/dt = [-10Ae^{-10t}] + [-2.5Be^{-2.5t}],$$

$$v(0) = 0 = L di(0)/dt \text{ or } di(0)/dt = 0 = -10A - 2.5B \text{ or } B = -4A$$

$$\text{Thus, } A = 2 \text{ and } B = -8$$

$$\text{Clearly, } i(t) = \{ 9 + [2e^{-10t}] + [-8e^{-2.5t}] \} \text{ A}$$

Chapter 8, Problem 51.

Find $v(t)$ for $t > 0$ in the circuit of Fig. 8.98.

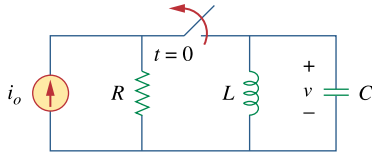

Figure 8.98

For Prob. 8.51.

Chapter 8, Solution 51.

Let i = inductor current and v = capacitor voltage.

$$\text{At } t = 0, v(0) = 0 \text{ and } i(0) = i_o.$$

For $t > 0$, we have a parallel, source-free LC circuit ($R = \infty$).

$$\alpha = 1/(2RC) = 0 \text{ and } \omega_o = 1/\sqrt{LC} \text{ which leads to } s_{1,2} = \pm j\omega_o$$

$$v = A\cos\omega_o t + B\sin\omega_o t, v(0) = 0 \text{ A}$$

$$i_C = Cdv/dt = -i$$

$$dv/dt = \omega_o B\sin\omega_o t = -i/C$$

$$dv(0)/dt = \omega_o B = -i_o/C \text{ therefore } B = i_o/(\omega_o C)$$

$$v(t) = \underline{\underline{-\frac{i_o}{(\omega_o C)}\sin\omega_o t \text{ V where } \omega_o = \frac{1}{\sqrt{LC}}}}$$

Chapter 8, Problem 52.

The step response of a parallel RLC circuit is

$$v = 10 + 20e^{-300t}(\cos 400t - 2 \sin 400t)\text{V}, \quad t \geq 0$$

when the inductor is 50 mH. Find R and C .

Chapter 8, Solution 52.

$$\alpha = 300 = \frac{1}{2RC} \tag{1}$$

$$\omega_d = \sqrt{\omega_o^2 - \alpha^2} = 400 \quad \longrightarrow \quad \omega_o = \sqrt{400^2 - 300^2} = 264.575 = \frac{1}{\sqrt{LC}} \tag{2}$$

From (2),

$$C = \frac{1}{(264.575)^2 \times 50 \times 10^{-3}} = \underline{285.71 \mu\text{F}}$$

From (1),

$$R = \frac{1}{2\alpha C} = \frac{1}{2 \times 300} (3500) = \underline{5.833 \Omega}$$

Chapter 8, Problem 53.

After being open for a day, the switch in the circuit of Fig. 8.99 is closed at $t = 0$. Find the differential equation describing $i(t)$, $t > 0$.

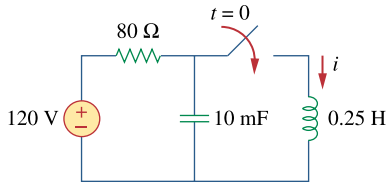
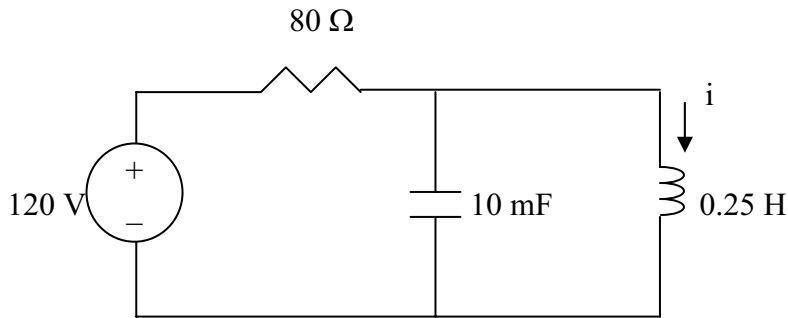

Figure 8.99
For Prob. 8.53.

Chapter 8, Solution 53.

At $t < 0$, $i(0^-) = 0$, $v_c(0^-) = 120\text{V}$

For $t > 0$, we have the circuit as shown below.



$$\frac{120 - V}{R} = C \frac{dv}{dt} + i \quad \longrightarrow \quad 120 = V + RC \frac{dv}{dt} + iR \quad (1)$$

But $v_L = v = L \frac{di}{dt}$ (2)

Substituting (2) into (1) yields

$$120 = L \frac{di}{dt} + RCL \frac{d^2i}{dt^2} + iR \quad \longrightarrow \quad 120 = \frac{1}{4} \frac{di}{dt} + 80 \times \frac{1}{4} \times 10 \times 10^{-3} \frac{d^2i}{dt^2} + 80i$$

or

$$\underline{\underline{(d^2i/dt^2) + 0.125(di/dt) + 400i = 600}}$$

Chapter 8, Problem 54.

The switch in Fig. 8.100 moves from position A to B at $t = 0$. Determine: (a) $i(0^+)$ and $v(0^+)$, (b) $di(0^+)/dt$, (c) $i(\infty)$ and $v(\infty)$.

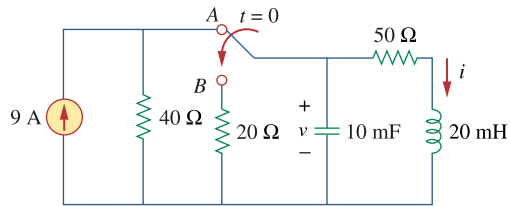
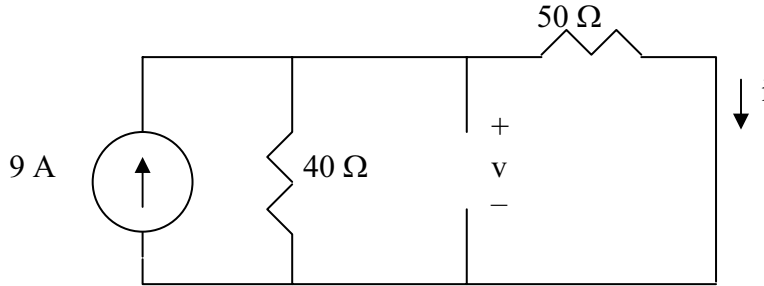

Figure 8.100
For Prob. 8.54.

Chapter 8, Solution 54.

(a) When the switch is at A, the circuit has reached steady state. Under this condition, the circuit is as shown below.



$$i(0^-) = \frac{40}{50 + 40}(9) = 4 \text{ A}, \quad v(0^-) = 50i = 50 \times 4 = 200 \text{ V}$$

$$v(0^+) = v(0^-) = \underline{200 \text{ V}}$$

$$i(0^+) = i(0^-) = \underline{4 \text{ A}}$$

$$(b) \quad v_L = L \frac{di}{dt} \quad \longrightarrow \quad \frac{di(0)}{dt} = \frac{v_L(0^+)}{L}$$

At $t = 0^+$, the right hand loop becomes,

$$-200 + 50 \times 4 + v_L(0^+) = 0 \text{ or } v_L(0^+) = 0 \text{ and } (di(0^+)/dt) = \underline{0}.$$

$$i_c = C \frac{dv}{dt} \quad \longrightarrow \quad \frac{dv(0^+)}{dt} = \frac{i_c(0^+)}{C}$$

At $t = 0^+$, and looking at the current flowing out of the node at the top of the circuit,

$$((200-0)/20) + i_c + 4 = 0 \text{ or } i_c = -14 \text{ A}.$$

Therefore,

$$dv(0^+)/dt = -14/0.01 = \underline{-1.4 \text{ kV/s}}.$$

(a) When the switch is in position B, the circuit reaches steady state. Since it is source-free, i and v decay to zero with time.

$$\underline{i(\infty) = 0, v(\infty) = 0}$$

Chapter 8, Problem 55.

For the circuit in Fig. 8.101, find $v(t)$ for $t > 0$. Assume that $v(0^+) = 4$ V and $i(0^+) = 2$ A.

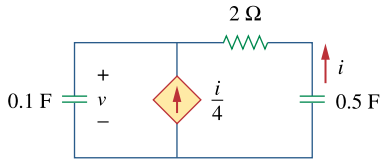

Figure 8.101
For Prob. 8.55.

Chapter 8, Solution 55.

At the top node, writing a KCL equation produces,

$$i/4 + i = C_1 dv/dt, \quad C_1 = 0.1$$

$$5i/4 = C_1 dv/dt = 0.1 dv/dt$$

$$i = 0.08 dv/dt \tag{1}$$

But,
$$v = -(2i + (1/C_2) \int i dt), \quad C_2 = 0.5$$

$$\text{or} \quad -dv/dt = 2di/dt + 2i \tag{2}$$

Substituting (1) into (2) gives,

$$-dv/dt = 0.16 d^2v/dt^2 + 0.16 dv/dt$$

$$0.16 d^2v/dt^2 + 0.16 dv/dt + dv/dt = 0, \text{ or } d^2v/dt^2 + 7.25 dv/dt = 0$$

$$\text{Which leads to } s^2 + 7.25s = 0 = s(s + 7.25) \text{ or } s_{1,2} = 0, -7.25$$

$$v(t) = A + Be^{-7.25t} \tag{3}$$

$$v(0) = 4 = A + B \tag{4}$$

From (1),
$$i(0) = 2 = 0.08 dv(0+)/dt \text{ or } dv(0+)/dt = 25$$

But,
$$dv/dt = -7.25Be^{-7.25t}, \text{ which leads to,}$$

$$dv(0)/dt = -7.25B = 25 \text{ or } B = -3.448 \text{ and } A = 4 - B = 4 + 3.448 = 7.448$$

$$\text{Thus, } v(t) = \underline{\underline{\{7.448 - 3.448e^{-7.25t}\} \text{ V}}}$$

Chapter 8, Problem 56.

In the circuit of Fig. 8.102, find $i(t)$ for $t > 0$.

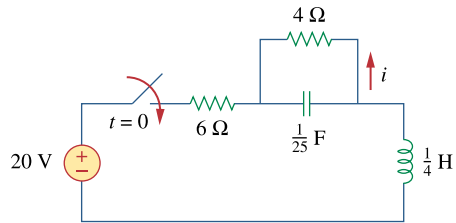
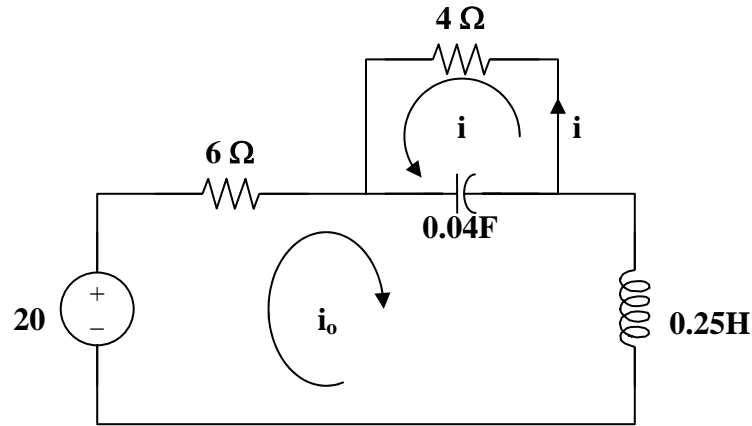

Figure 8.102
For Prob. 8.56.

Chapter 8, Solution 56.

For $t < 0$, $i(0) = 0$ and $v(0) = 0$.

For $t > 0$, the circuit is as shown below.



Applying KVL to the larger loop,

$$-20 + 6i_o + 0.25di_o/dt + 25 \int (i_o + i)dt = 0 \quad (1)$$

For the smaller loop, $4i + 25 \int (i + i_o)dt = 0$ or $\int (i + i_o)dt = -0.16i$ (2)

Taking the derivative, $4di/dt + 25(i + i_o) = 0$ or $i_o = -0.16di/dt - i$ (3)

and $di_o/dt = -0.16d^2i/dt^2 - di/dt$ (4)

From (1), (2), (3), and (4), $-20 - 0.96di/dt - 6i - 0.04d^2i/dt^2 - 0.25di/dt - 4i = 0$

Which becomes, $d^2i/dt^2 + 30.25di/dt + 250i = -500$

This leads to, $s^2 + 30.25s + 250 = 0$

$$\text{or } s_{1,2} = \frac{-30.25 \pm \sqrt{(30.25)^2 - 1000}}{2} = -15.125 \pm j4.608$$

This is clearly an underdamped response.

Thus, $i(t) = I_s + e^{-15.125t}(A_1\cos(4.608t) + A_2\sin(4.608t))A$.

At $t = 0$, $i_0(0) = 0$ and $i(0) = 0 = I_s + A_1$ or $A_1 = -I_s$. As t approaches infinity, $i_0(\infty) = 20/10 = 2A = -i(\infty)$ or $i(\infty) = -2A = I_s$ and $A_1 = 2$.

In addition, from (3), we get $di(0)/dt = -6.25i_0(0) - 6.25i(0) = 0$.

$di/dt = 0 - 15.125 e^{-15.125t}(A_1\cos(4.608t) + A_2\sin(4.608t)) + e^{-15.125t}(-A_14.608\sin(4.608t) + A_24.608\cos(4.608t))$. At $t=0$, $di(0)/dt = 0 = -15.125A_1 + 4.608A_2 = -30.25 + 4.608A_2$ or $A_2 = 30.25/4.608 = 6.565$.

This leads to,

$$i(t) = \underline{\underline{(-2 + e^{-15.125t}(2\cos(4.608t) + 6.565\sin(4.608t))) A}}$$

Chapter 8, Problem 57.

If the switch in Fig. 8.103 has been closed for a long time before $t = 0$, but is opened at $t = 0$ determine:

- (a) the characteristic equation of the circuit,
- (b) i_x and v_R for $t > 0$.

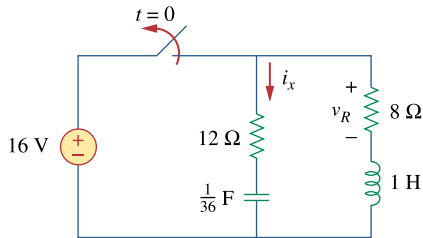

Figure 8.103
For Prob. 8.57.

Chapter 8, Solution 57.

(a) Let v = capacitor voltage and i = inductor current. At $t = 0^-$, the switch is closed and the circuit has reached steady-state.

$$v(0^-) = 16\text{V and } i(0^-) = 16/8 = 2\text{A}$$

At $t = 0^+$, the switch is open but, $v(0^+) = 16$ and $i(0^+) = 2$.

We now have a source-free RLC circuit.

$$R = 8 + 12 = 20 \text{ ohms, } L = 1\text{H, } C = 4\text{mF.}$$

$$\alpha = R/(2L) = (20)/(2 \times 1) = 10$$

$$\omega_0 = 1/\sqrt{LC} = 1/\sqrt{1 \times (1/36)} = 6$$

Since $\alpha > \omega_0$, we have a overdamped response.

$$s_{1,2} = -\alpha \pm \sqrt{\alpha^2 - \omega_0^2} = -18, -2$$

Thus, the characteristic equation is $(s + 2)(s + 18) = 0$ or **$s^2 + 20s + 36 = 0$** .

$$(b) \quad i(t) = [Ae^{-2t} + Be^{-18t}] \text{ and } i(0) = 2 = A + B \quad (1)$$

To get $di(0)/dt$, consider the circuit below at $t = 0+$.

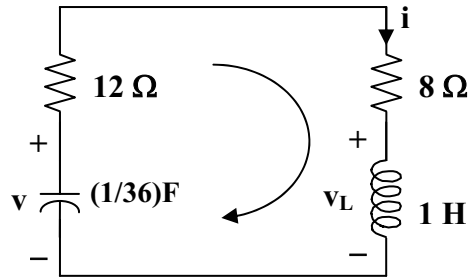

$$-v(0) + 20i(0) + v_L(0) = 0, \text{ which leads to,}$$

$$-16 + 20 \times 2 + v_L(0) = 0 \text{ or } v_L(0) = -24$$

$$Ldi(0)/dt = v_L(0) \text{ which gives } di(0)/dt = v_L(0)/L = -24/1 = -24 \text{ A/s}$$

$$\text{Hence } -24 = -2A - 18B \text{ or } 12 = A + 9B \quad (2)$$

$$\text{From (1) and (2),} \quad B = 1.25 \text{ and } A = 0.75$$

$$i(t) = [0.75e^{-2t} + 1.25e^{-18t}] = -i_x(t) \text{ or } i_x(t) = \underline{[-0.75e^{-2t} - 1.25e^{-18t}] \text{ A}}$$

$$v(t) = 8i(t) = \underline{[6e^{-2t} + 10e^{-18t}] \text{ A}}$$

Chapter 8, Problem 58.

In the circuit of Fig. 8.104, the switch has been in position 1 for a long time but moved to position 2 at $t = 0$. Find:

- (a) $v(0^+)$, $dv(0^+)/dt$
 (b) $v(t)$ for $t \geq 0$

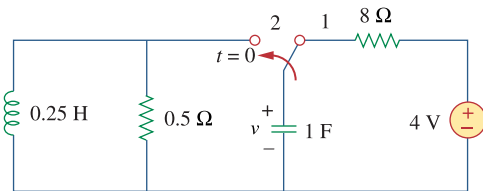

Figure 8.104
 For Prob. 8.58.

Chapter 8, Solution 58.

- (a) Let i = inductor current, v = capacitor voltage $i(0) = 0$, $v(0) = 4$

$$\frac{dv(0)}{dt} = -\frac{[v(0) + Ri(0)]}{RC} = -\frac{(4 + 0)}{0.5} = -8 \text{ V/s}$$

- (b) For $t \geq 0$, the circuit is a source-free RLC parallel circuit.

$$\alpha = \frac{1}{2RC} = \frac{1}{2 \times 0.5 \times 1} = 1, \quad \omega_o = \frac{1}{\sqrt{LC}} = \frac{1}{\sqrt{0.25 \times 1}} = 2$$

$$\omega_d = \sqrt{\omega_o^2 - \alpha^2} = \sqrt{4 - 1} = 1.732$$

Thus,

$$v(t) = e^{-t}(A_1 \cos 1.732t + A_2 \sin 1.732t)$$

$$v(0) = 4 = A_1$$

$$\frac{dv}{dt} = -e^{-t}A_1 \cos 1.732t - 1.732e^{-t}A_1 \sin 1.732t - e^{-t}A_2 \sin 1.732t + 1.732e^{-t}A_2 \cos 1.732t$$

$$\frac{dv(0)}{dt} = -8 = -A_1 + 1.732A_2 \quad \longrightarrow \quad A_2 = -2.309$$

$$v(t) = e^{-t}(4 \cos 1.732t - 2.309 \sin 1.732t) \text{ V}$$

Chapter 8, Problem 59.

The make before break switch in Fig. 8.105 has been in position 1 for $t < 0$. At $t = 0$, it is moved instantaneously to position 2. Determine $v(t)$.

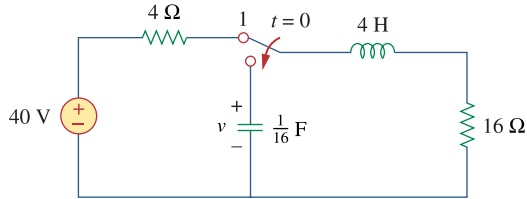

Figure 8.105
For Prob. 8.59.

Chapter 8, Solution 59.

Let i = inductor current and v = capacitor voltage

$$v(0) = 0, \quad i(0) = 40/(4+16) = 2\text{A}$$

For $t > 0$, the circuit becomes a source-free series RLC with

$$\alpha = \frac{R}{2L} = \frac{16}{2 \times 4} = 2, \quad \omega_o = \frac{1}{\sqrt{LC}} = \frac{1}{\sqrt{4 \times 1/16}} = 2, \quad \longrightarrow \quad \alpha = \omega_o = 2$$

$$i(t) = Ae^{-2t} + Bte^{-2t}$$

$$i(0) = 2 = A$$

$$\frac{di}{dt} = -2Ae^{-2t} + Be^{-2t} - 2Bte^{-2t}$$

$$\frac{di(0)}{dt} = -2A + B = -\frac{1}{L}[Ri(0) - v(0)] \quad \longrightarrow \quad -2A + B = -\frac{1}{4}(32 - 0), \quad B = -4$$

$$i(t) = 2e^{-2t} - 4te^{-2t}$$

$$v = \frac{1}{C} \int_0^t -i dt + v(0) = -32 \int_0^t e^{-2t} dt + 64 \int_0^t te^{-2t} dt = +16e^{-2t} \Big|_0^t + \frac{64}{4} e^{-2t} (-2t - 1) \Big|_0^t$$

$$v = \underline{\underline{-32te^{-2t} \text{ V}}}.$$

Checking,

$$v = Ldi/dt + Ri = 4(-4e^{-2t} - 4e^{-2t} + 8e^{-2t}) + 16(2e^{-2t} - 4te^{-2t}) = -32te^{-2t} \text{ V}.$$

Chapter 8, Problem 60.

Obtain i_1 and i_2 for $t > 0$ in the circuit of Fig. 8.106.

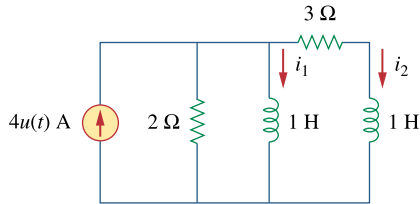

Figure 8.106
For Prob. 8.60.

Chapter 8, Solution 60.

$$\text{At } t = 0^-, 4u(t) = 0 \text{ so that } i_1(0) = 0 = i_2(0) \quad (1)$$

Applying nodal analysis,

$$4 = 0.5di_1/dt + i_1 + i_2 \quad (2)$$

$$\text{Also, } i_2 = [1di_1/dt - 1di_2/dt]/3 \text{ or } 3i_2 = di_1/dt - di_2/dt \quad (3)$$

$$\text{Taking the derivative of (2), } 0 = d^2i_1/dt^2 + 2di_1/dt + 2di_2/dt \quad (4)$$

$$\begin{aligned} \text{From (2) and (3), } di_2/dt &= di_1/dt - 3i_2 = di_1/dt - 3(4 - i_1 - 0.5di_1/dt) \\ &= di_1/dt - 12 + 3i_1 + 1.5di_1/dt \end{aligned}$$

Substituting this into (4),

$$d^2i_1/dt^2 + 7di_1/dt + 6i_1 = 24 \text{ which gives } s^2 + 7s + 6 = 0 = (s + 1)(s + 6)$$

$$\text{Thus, } i_1(t) = I_s + [Ae^{-t} + Be^{-6t}], 6I_s = 24 \text{ or } I_s = 4$$

$$i_1(t) = 4 + [Ae^{-t} + Be^{-6t}] \text{ and } i_1(0) = 4 + [A + B] \quad (5)$$

$$\begin{aligned} i_2 &= 4 - i_1 - 0.5di_1/dt = i_1(t) = 4 + -4 - [Ae^{-t} + Be^{-6t}] - [-Ae^{-t} - 6Be^{-6t}] \\ &= [-0.5Ae^{-t} + 2Be^{-6t}] \text{ and } i_2(0) = 0 = -0.5A + 2B \end{aligned} \quad (6)$$

$$\text{From (5) and (6), } A = -3.2 \text{ and } B = -0.8$$

$$i_1(t) = \underline{\underline{\{4 + [-3.2e^{-t} - 0.8e^{-6t}]\} \text{ A}}}$$

$$i_2(t) = \underline{\underline{\{1.6e^{-t} - 1.6e^{-6t}\} \text{ A}}}$$

Chapter 8, Problem 61.

For the circuit in Prob. 8.5, find i and v for $t > 0$.

Chapter 8, Solution 61.

For $t > 0$, we obtain the natural response by considering the circuit below.

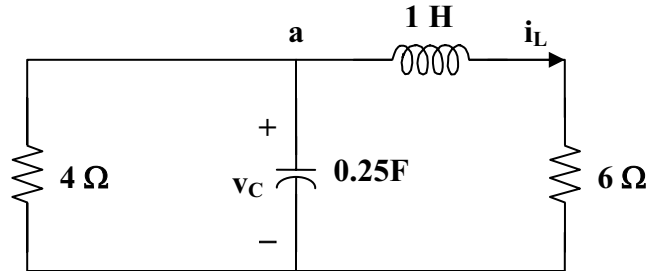

At node a, $v_C/4 + 0.25dv_C/dt + i_L = 0$ (1)

But, $v_C = 1di_L/dt + 6i_L$ (2)

Combining (1) and (2),

$$(1/4)di_L/dt + (6/4)i_L + 0.25d^2i_L/dt^2 + (6/4)di_L/dt + i_L = 0$$

$$d^2i_L/dt^2 + 7di_L/dt + 10i_L = 0$$

$$s^2 + 7s + 10 = 0 = (s + 2)(s + 5) \text{ or } s_{1,2} = -2, -5$$

$$\text{Thus, } i_L(t) = i_L(\infty) + [Ae^{-2t} + Be^{-5t}],$$

where $i_L(\infty)$ represents the final inductor current = $4(4)/(4 + 6) = 1.6$

$$i_L(t) = 1.6 + [Ae^{-2t} + Be^{-5t}] \text{ and } i_L(0) = 1.6 + [A+B] \text{ or } -1.6 = A+B \quad (3)$$

$$di_L/dt = [-2Ae^{-2t} - 5Be^{-5t}]$$

$$\text{and } di_L(0)/dt = 0 = -2A - 5B \text{ or } A = -2.5B \quad (4)$$

From (3) and (4), $A = -8/3$ and $B = 16/15$

$$i_L(t) = 1.6 + [-(8/3)e^{-2t} + (16/15)e^{-5t}]$$

$$v(t) = 6i_L(t) = \underline{\underline{\{9.6 + [-16e^{-2t} + 6.4e^{-5t}]\} \text{ V}}}$$

$$v_C = 1di_L/dt + 6i_L = [(16/3)e^{-2t} - (16/3)e^{-5t}] + \{9.6 + [-16e^{-2t} + 6.4e^{-5t}]\}$$

$$v_C = \{9.6 + [-(32/3)e^{-2t} + 1.0667e^{-5t}]\}$$

$$i(t) = v_C/4 = \underline{\underline{\{2.4 + [-2.667e^{-2t} + 0.2667e^{-5t}]\} \text{ A}}}$$

Chapter 8, Problem 62.

Find the response $v_R(t)$ for $t > 0$ in the circuit of Fig. 8.107. Let $R = 3\Omega$, $L = 2\text{H}$, $C = 1/18\text{F}$.

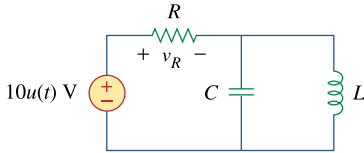

Figure 8.107
For Prob. 8.62.

Chapter 8, Solution 62.

This is a parallel RLC circuit as evident when the voltage source is turned off.

$$\alpha = 1/(2RC) = (1)/(2 \times 3 \times (1/18)) = 3$$

$$\omega_0 = 1/\sqrt{LC} = 1/\sqrt{2 \times 1/18} = 3$$

Since $\alpha = \omega_0$, we have a critically damped response.

$$s_{1,2} = -3$$

Let $v(t)$ = capacitor voltage

Thus, $v(t) = V_s + [(A + Bt)e^{-3t}]$ where $V_s = 0$

$$\text{But } -10 + v_R + v = 0 \text{ or } v_R = 10 - v$$

Therefore $v_R = \underline{10 - [(A + Bt)e^{-3t}]}$ where A and B are determined from initial conditions.

Chapter 8, Problem 63.

For the op amp circuit in Fig. 8.108, find the differential equation for $i(t)$.

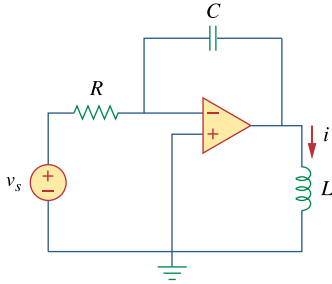

Figure 8.108
For Prob. 8.63.

Chapter 8, Solution 63.

$$\frac{v_s - 0}{R} = C \frac{d(0 - v_o)}{dt} \longrightarrow \frac{v_s}{R} = -C \frac{dv_o}{dt}$$
$$v_o = L \frac{di}{dt} \longrightarrow \frac{dv_o}{dt} = L \frac{d^2i}{dt^2} = -\frac{v_s}{RC}$$

Thus,

$$\underline{\underline{\frac{d^2i(t)}{dt^2} = -\frac{v_s}{RCL}}}$$

Chapter 8, Problem 64.

For the op amp circuit in Fig. 8.109, derive the differential equation relating v_o to v_s .

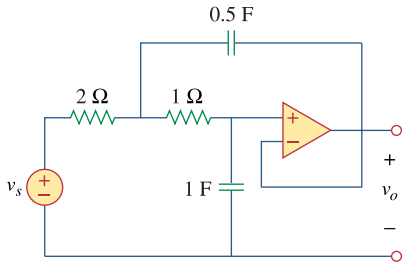
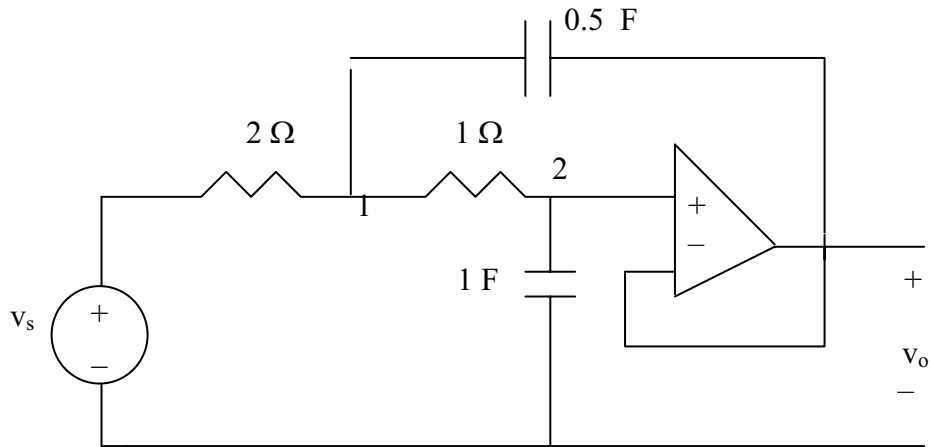

Figure 8.109
For Prob. 8.64.

Chapter 8, Solution 64.

Consider the circuit as shown below.



At node 1,

$$\frac{v_s - v_1}{2} = \frac{v_1 - v_2}{1} + \frac{1}{2} \frac{d}{dt}(v_1 - v_o) \quad \longrightarrow \quad v_s = 3v_1 - 2v_2 + \frac{d}{dt}(v_1 - v_o) \quad (1)$$

At node 2,

$$\frac{v_1 - v_2}{1} = 1 \frac{d}{dt}(v_2 - 0) \quad \longrightarrow \quad v_1 - v_2 = \frac{dv_2}{dt} \quad (2)$$

But $v_2 = v_o$ so that (1) and (2) become

$$v_s = 3v_1 - 2v_o + \frac{d}{dt}(v_1 - v_o) \quad (1a)$$

$$v_1 = v_o + \frac{dv_o}{dt} \quad (2a)$$

Substituting (2a) into (1a) gives

$$v_s = 3v_o + 3 \frac{dv_o}{dt} - 2v_o + \frac{dv_o}{dt} + \frac{d^2v_o}{dt^2} - \frac{dv_o}{dt}$$

$$\underline{v_s = \frac{d^2v_o}{dt^2} + 3 \frac{dv_o}{dt} + v_o}$$

Chapter 8, Problem 65.

Determine the differential equation for the op amp circuit in Fig. 8.110. If $v_1(0^+) = 2\text{ V}$ and $v_2(0^+) = 0\text{ V}$ find v_o for $t > 0$. Let $R = 100\text{ k}\Omega$ and $C = 1\text{ }\mu\text{F}$.

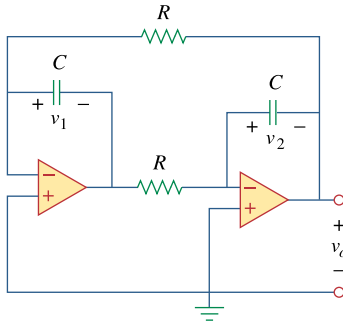

Figure 8.110
For Prob. 8.65.

Chapter 8, Solution 65.

At the input of the first op amp,

$$(v_o - 0)/R = Cd(v_1 - 0)/dt \quad (1)$$

At the input of the second op amp,

$$(-v_1 - 0)/R = Cdv_2/dt \quad (2)$$

Let us now examine our constraints. Since the input terminals are essentially at ground, then we have the following,

$$v_o = -v_2 \text{ or } v_2 = -v_o \quad (3)$$

Combining (1), (2), and (3), eliminating v_1 and v_2 we get,

$$\frac{d^2 v_o}{dt^2} - \left(\frac{1}{R^2 C^2} \right) v_o = \frac{d^2 v_o}{dt^2} - 100 v_o = 0$$

$$\text{Which leads to } s^2 - 100 = 0$$

Clearly this produces roots of -10 and $+10$.

And, we obtain,

$$v_o(t) = (Ae^{+10t} + Be^{-10t})V$$

$$\text{At } t = 0, v_o(0+) = -v_2(0+) = 0 = A + B, \text{ thus } B = -A$$

This leads to $v_o(t) = (Ae^{+10t} - Ae^{-10t})V$. Now we can use $v_1(0+) = 2V$.

$$\text{From (2), } v_1 = -RCdv_2/dt = 0.1dv_o/dt = 0.1(10Ae^{+10t} + 10Ae^{-10t})$$

$$v_1(0+) = 2 = 0.1(20A) = 2A \text{ or } A = 1$$

$$\text{Thus, } v_o(t) = \underline{(e^{+10t} - e^{-10t})V}$$

It should be noted that this circuit is unstable (clearly one of the poles lies in the right-half-plane).

Chapter 8, Problem 66.

Obtain the differential equations for $v_o(t)$ in the op amp circuit of Fig. 8.111.

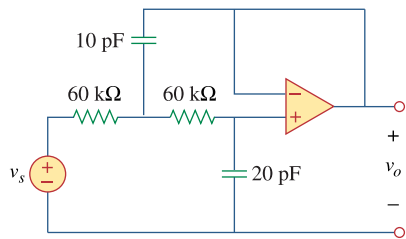
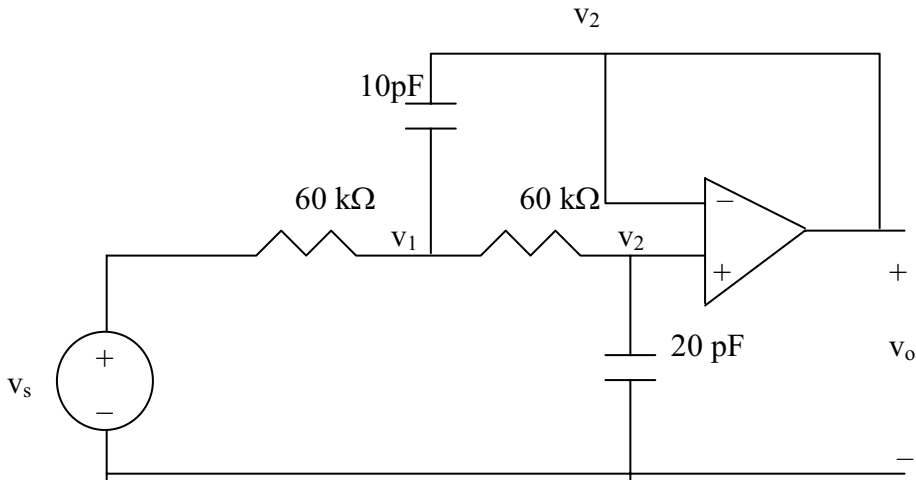

Figure 8.111
For Prob. 8.66.

Chapter 8, Solution 66.

We apply nodal analysis to the circuit as shown below.



At node 1,

$$\frac{v_s - v_1}{60k} = \frac{v_1 - v_2}{60k} + 10pF \frac{d}{dt}(v_1 - v_o)$$

But $v_2 = v_o$

$$v_s = 2v_1 - v_o + 6 \times 10^{-7} \frac{d(v_1 - v_o)}{dt} \quad (1)$$

At node 2,

$$\frac{v_1 - v_2}{60k} = 20pF \frac{d}{dt}(v_2 - 0), \quad v_2 = v_o$$

$$v_1 = v_o + 1.2 \times 10^{-6} \frac{dv_o}{dt} \quad (2)$$

Substituting (2) into (1) gives

$$v_s = 2 \left(v_o + 1.2 \times 10^{-6} \frac{dv_o}{dt} \right) - v_o + 6 \times 10^{-7} \left(1.2 \times 10^{-6} \frac{d^2 v_o}{dt^2} \right)$$

$$v_s = \underline{v_o + 2.4 \times 10^{-6} (dv_o/dt) + 7.2 \times 10^{-13} (d^2 v_o/dt^2)}.$$

Chapter 8, Problem 67.

* In the op amp circuit of Fig. 8.112, determine $v_o(t)$ for $t > 0$. Let $v_{in} = u(t)$ V, $R_1 = R_2 = 10\text{ k}\Omega$, $C_1 = C_2 = 100\text{ }\mu\text{F}$.

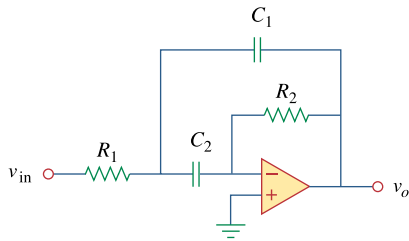

Figure 8.112
For Prob. 8.67.

* An asterisk indicates a challenging problem.

Chapter 8, Solution 67.

At node 1,

$$\frac{v_{in} - v_1}{R_1} = C_1 \frac{d(v_1 - v_o)}{dt} + C_2 \frac{d(v_1 - 0)}{dt} \quad (1)$$

At node 2,

$$C_2 \frac{d(v_1 - 0)}{dt} = \frac{0 - v_o}{R_2}, \text{ or } \frac{dv_1}{dt} = \frac{-v_o}{C_2 R_2} \quad (2)$$

From (1) and (2),

$$v_{in} - v_1 = -\frac{R_1 C_1}{C_2 R_2} \frac{dv_o}{dt} - R_1 C_1 \frac{dv_o}{dt} - R_1 \frac{v_o}{R_2}$$

$$v_1 = v_{in} + \frac{R_1 C_1}{C_2 R_2} \frac{dv_o}{dt} + R_1 C_1 \frac{dv_o}{dt} + R_1 \frac{v_o}{R_2} \quad (3)$$

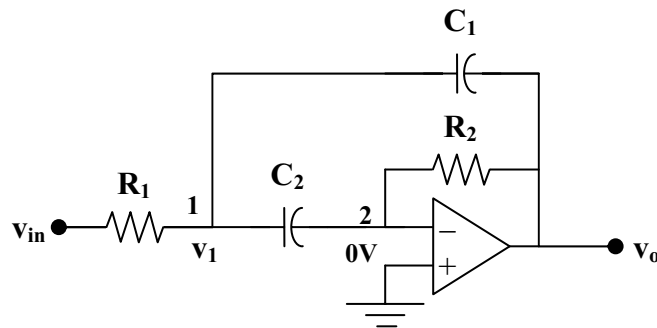

From (2) and (3),

$$-\frac{v_o}{C_2 R_2} = \frac{dv_1}{dt} = \frac{dv_{in}}{dt} + \frac{R_1 C_1}{C_2 R_2} \frac{dv_o}{dt} + R_1 C_1 \frac{d^2 v_o}{dt^2} + \frac{R_1}{R_2} \frac{dv_o}{dt}$$

$$\frac{d^2 v_o}{dt^2} + \frac{1}{R_2} \left(\frac{1}{C_1} + \frac{1}{C_2} \right) \frac{dv_o}{dt} + \frac{v_o}{C_1 C_2 R_2 R_1} = -\frac{1}{R_1 C_1} \frac{dv_{in}}{dt}$$

$$\text{But } C_1 C_2 R_1 R_2 = 10^{-4} \times 10^{-4} \times 10^4 \times 10^4 = 1$$

$$\frac{1}{R_2} \left(\frac{1}{C_1} + \frac{1}{C_2} \right) = \frac{2}{R_2 C_1} = \frac{2}{10^4 \times 10^{-4}} = 2$$

$$\frac{d^2 v_o}{dt^2} + 2 \frac{dv_o}{dt} + v_o = -\frac{dv_{in}}{dt}$$

Which leads to $s^2 + 2s + 1 = 0$ or $(s + 1)^2 = 0$ and $s = -1, -1$

$$\text{Therefore, } v_o(t) = [(A + Bt)e^{-t}] + V_f$$

As t approaches infinity, the capacitor acts like an open circuit so that

$$V_f = v_o(\infty) = 0$$

$v_{in} = 10u(t)$ mV and the fact that the initial voltages across each capacitor is 0

means that $v_o(0) = 0$ which leads to $A = 0$.

$$v_o(t) = [Bte^{-t}]$$

$$\frac{dv_o}{dt} = [(B - Bt)e^{-t}] \quad (4)$$

From (2),

$$\frac{dv_o(0+)}{dt} = -\frac{v_o(0+)}{C_2 R_2} = 0$$

From (1) at $t = 0+$,

$$\frac{1-0}{R_1} = -C_1 \frac{dv_o(0+)}{dt} \text{ which leads to } \frac{dv_o(0+)}{dt} = -\frac{1}{C_1 R_1} = -1$$

Substituting this into (4) gives $B = -1$

$$\text{Thus, } v(t) = \underline{-te^{-t}u(t)} \text{ V}$$

PROPRIETARY MATERIAL. © 2007 The McGraw-Hill Companies, Inc. All rights reserved. No part of this Manual may be displayed, reproduced or distributed in any form or by any means, without the prior written permission of the publisher, or used beyond the limited distribution to teachers and educators permitted by McGraw-Hill for their individual course preparation. If you are a student using this Manual, you are using it without permission.

Chapter 8, Problem 68.



For the step function $v_s = u(t)$, use *PSpice* to find the response $v(t)$ for $0 < t < 6$ s in the circuit of Fig. 8.113.

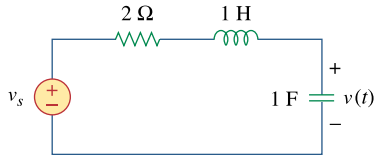
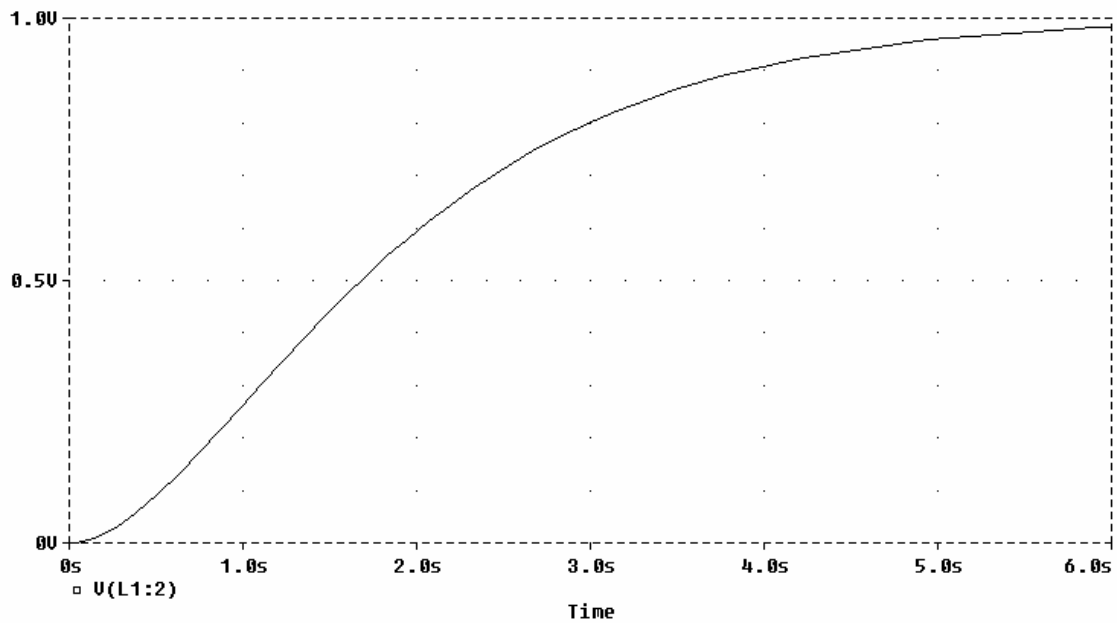
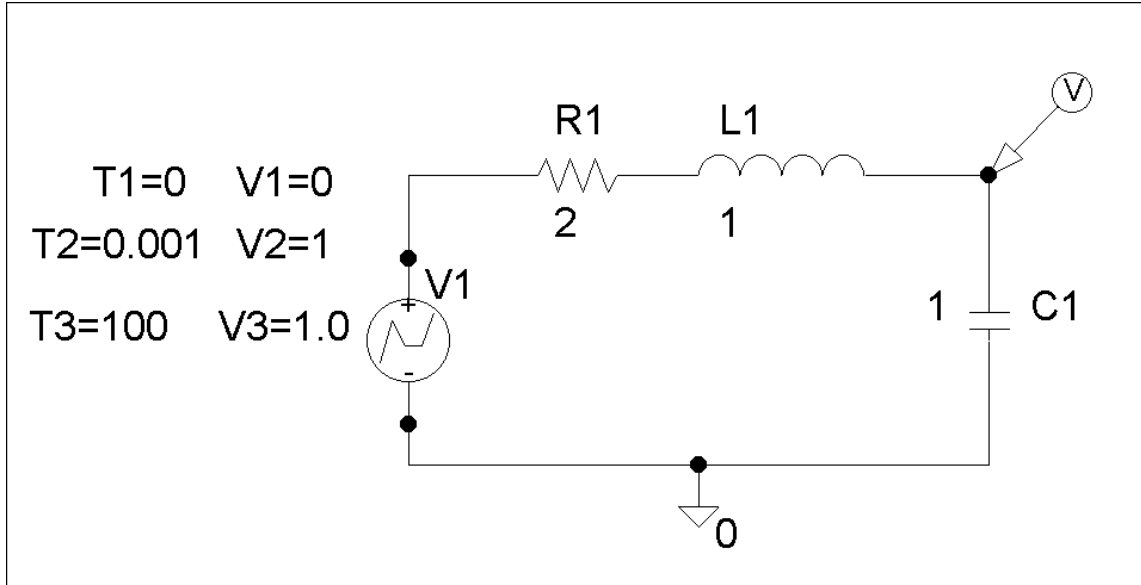

Figure 8.113

For Prob. 8.68.

Chapter 8, Solution 68.

The schematic is as shown below. The unit step is modeled by VPWL as shown. We insert a voltage marker to display V after simulation. We set Print Step = 25 ms and final step = 6s in the transient box. The output plot is shown below.



PROPRIETARY MATERIAL. © 2007 The McGraw-Hill Companies, Inc. All rights reserved. No part of this Manual may be displayed, reproduced or distributed in any form or by any means, without the prior written permission of the publisher, or used beyond the limited distribution to teachers and educators permitted by McGraw-Hill for their individual course preparation. If you are a student using this Manual, you are using it without permission.

Chapter 8, Problem 69.

Given the source-free circuit in Fig. 8.114, use *PSpice* to get $i(t)$ for $0 < t < 20$ s. Take $v(0) = 30$ V and $i(0) = 2$ A.

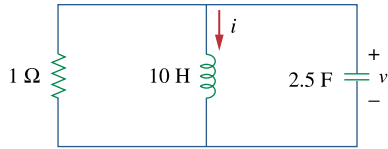
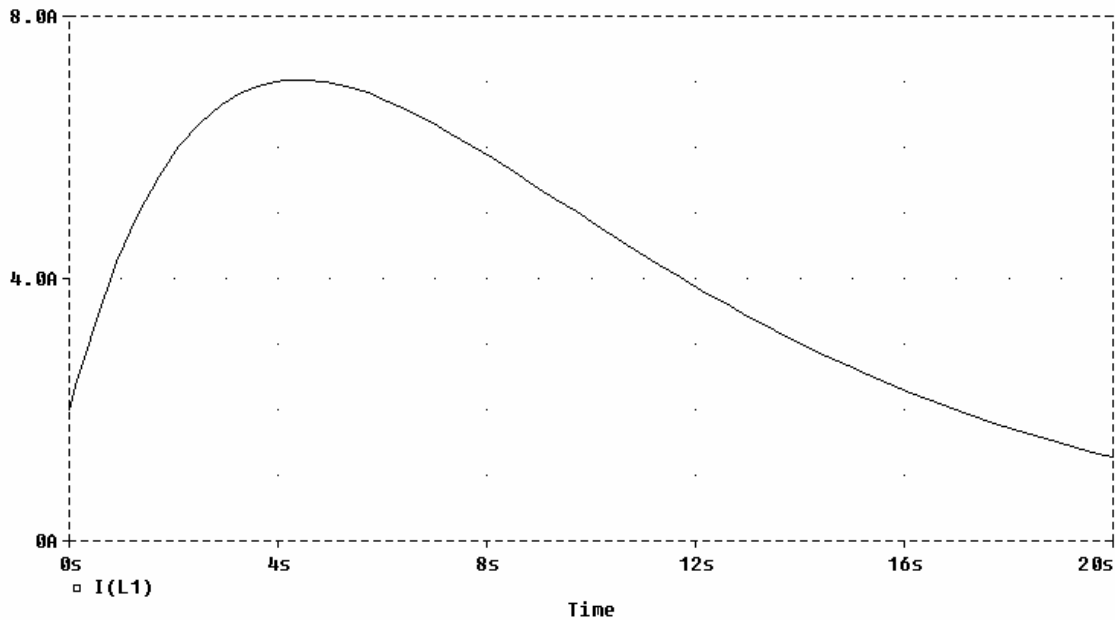
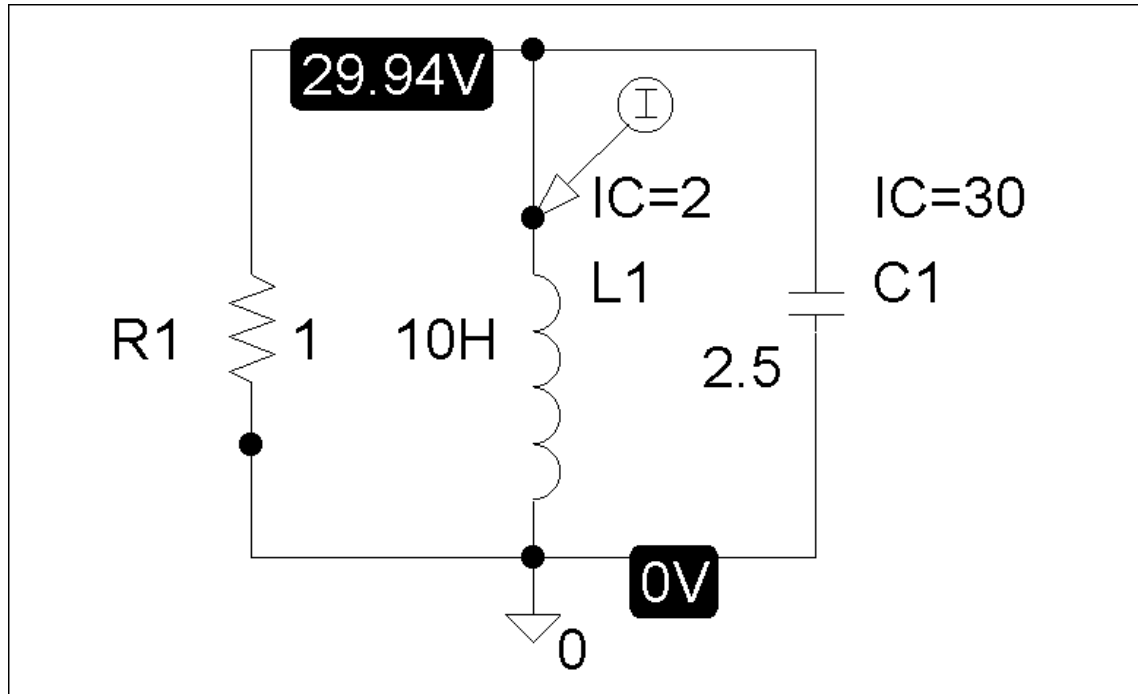

Figure 8.114
For Prob. 8.69.

Chapter 8, Solution 69.

The schematic is shown below. The initial values are set as attributes of L1 and C1. We set Print Step to 25 ms and the Final Time to 20s in the transient box. A current marker is inserted at the terminal of L1 to automatically display $i(t)$ after simulation. The result is shown below.



PROPRIETARY MATERIAL. © 2007 The McGraw-Hill Companies, Inc. All rights reserved. No part of this Manual may be displayed, reproduced or distributed in any form or by any means, without the prior written permission of the publisher, or used beyond the limited distribution to teachers and educators permitted by McGraw-Hill for their individual course preparation. If you are a student using this Manual, you are using it without permission.

Chapter 8, Problem 70.

For the circuit in Fig. 8.115, use *PSpice* to obtain $v(t)$ for $0 < t < 4$ s. Assume that the capacitor voltage and inductor current at $t = 0$ are both zero.

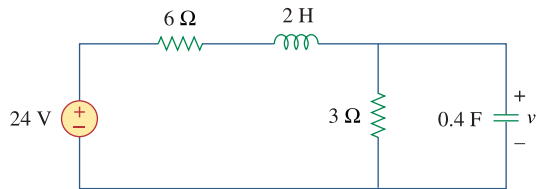
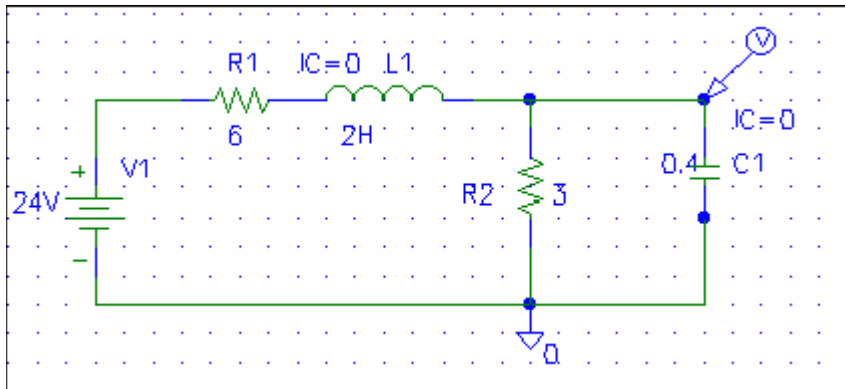

Figure 8.115
For Prob. 8.70.

Chapter 8, Solution 70.

The schematic is shown below.



After the circuit is saved and simulated, we obtain the capacitor voltage $v(t)$ as shown below.

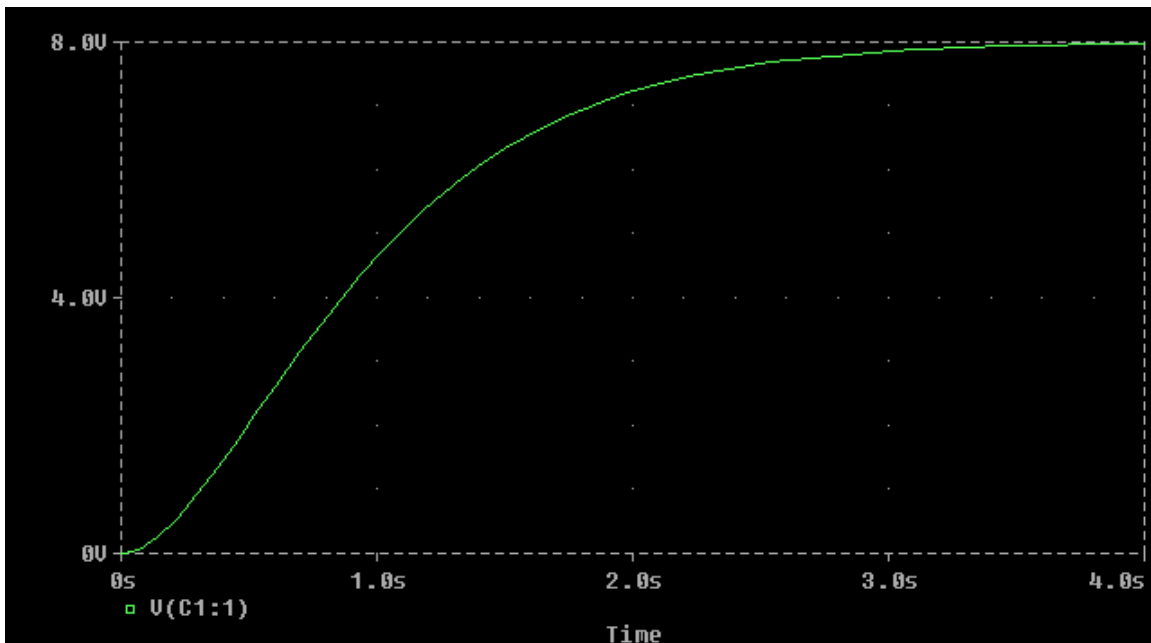

PROPRIETARY MATERIAL. © 2007 The McGraw-Hill Companies, Inc. All rights reserved. No part of this Manual may be displayed, reproduced or distributed in any form or by any means, without the prior written permission of the publisher, or used beyond the limited distribution to teachers and educators permitted by McGraw-Hill for their individual course preparation. If you are a student using this Manual, you are using it without permission.

Chapter 8, Problem 71.

Obtain $v(t)$ for $0 < t < 4$ s in the circuit of Fig. 8.116 using *PSpice*.

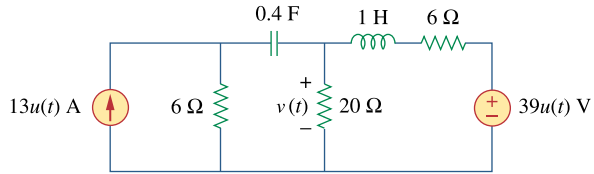
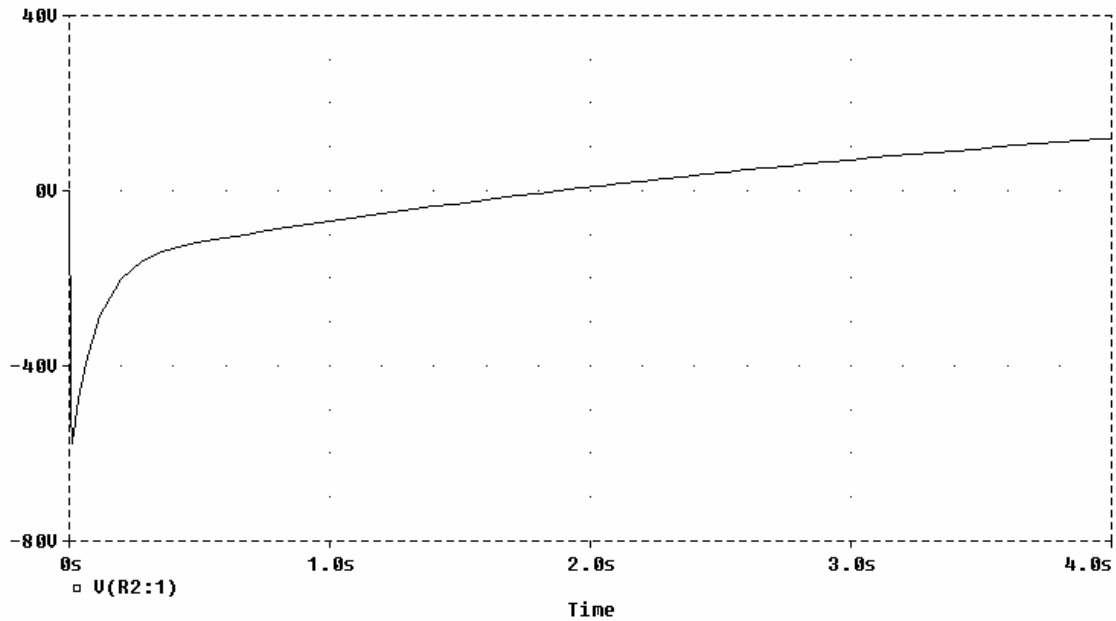
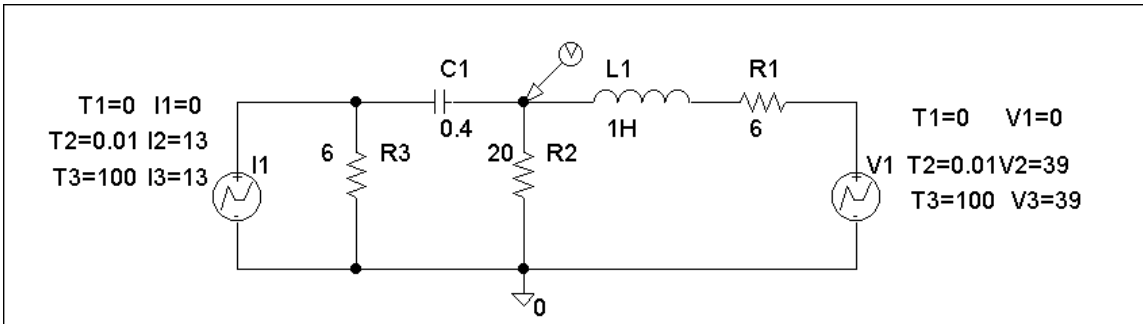

Figure 8.116
For Prob. 8.71.

Chapter 8, Solution 71.

The schematic is shown below. We use VPWL and IPWL to model the $39 u(t)$ V and $13 u(t)$ A respectively. We set Print Step to 25 ms and Final Step to 4s in the Transient box. A voltage marker is inserted at the terminal of R2 to automatically produce the plot of $v(t)$ after simulation. The result is shown below.



Chapter 8, Problem 72.

The switch in Fig. 8.117 has been in position 1 for a long time. At $t = 0$, it is switched to position 2. Use *PSpice* to find $i(t)$ for $0 < t < 0.2$ s.

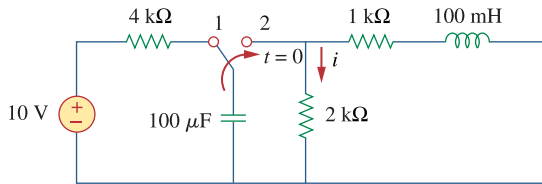
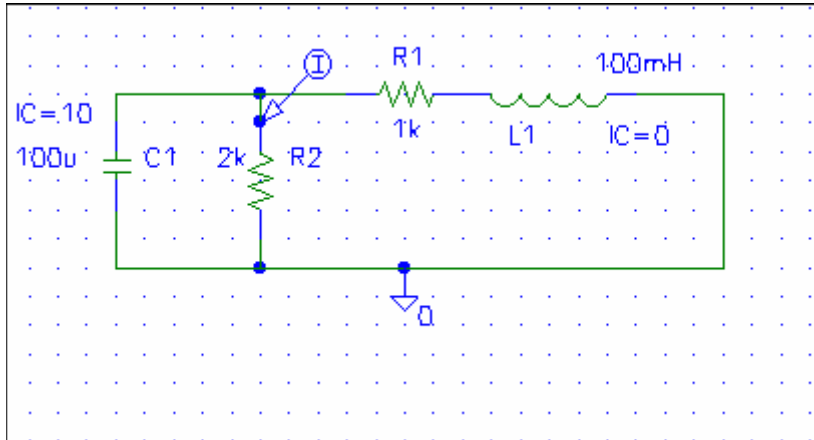

Figure 8.117
For Prob. 8.72.

Chapter 8, Solution 72.

When the switch is in position 1, we obtain $i_C=10$ for the capacitor and $i_C=0$ for the inductor. When the switch is in position 2, the schematic of the circuit is shown below.



When the circuit is simulated, we obtain $i(t)$ as shown below.

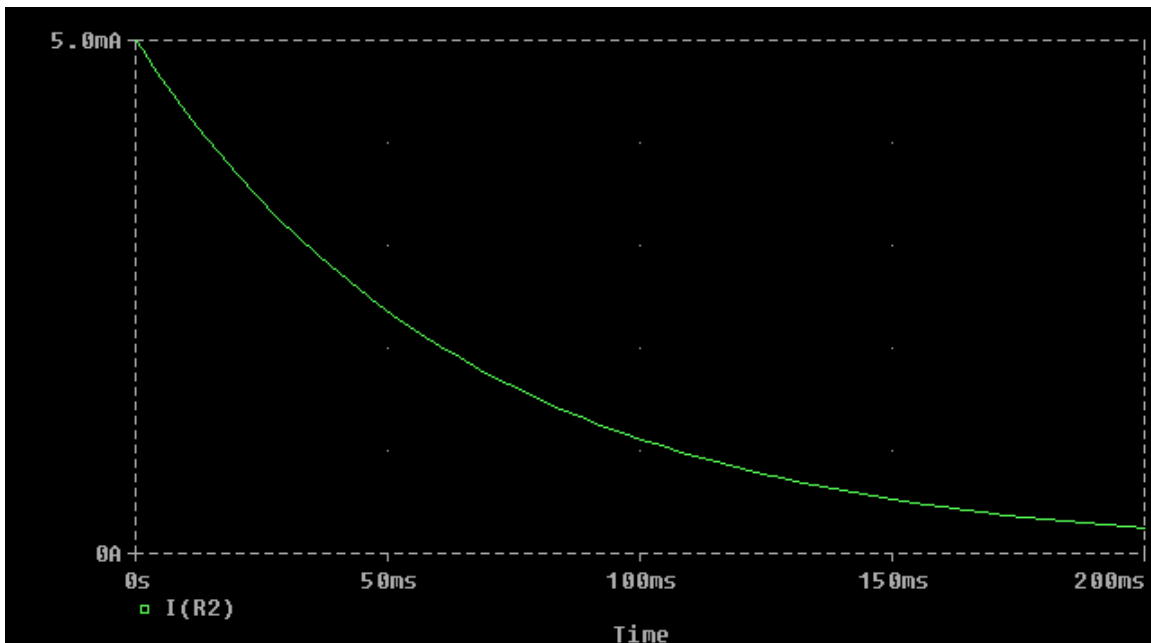

PROPRIETARY MATERIAL. © 2007 The McGraw-Hill Companies, Inc. All rights reserved. No part of this Manual may be displayed, reproduced or distributed in any form or by any means, without the prior written permission of the publisher, or used beyond the limited distribution to teachers and educators permitted by McGraw-Hill for their individual course preparation. If you are a student using this Manual, you are using it without permission.

Chapter 8, Problem 73.

Rework Prob. 8.25 using *PSpice*. Plot $v_o(t)$ for $0 < t < 4$ s.

Chapter 8, Solution 73.

- (a) For $t < 0$, we have the schematic below. When this is saved and simulated, we obtain the initial inductor current and capacitor voltage as

$$i_L(0) = 3 \text{ A} \quad \text{and} \quad v_c(0) = 24 \text{ V}.$$

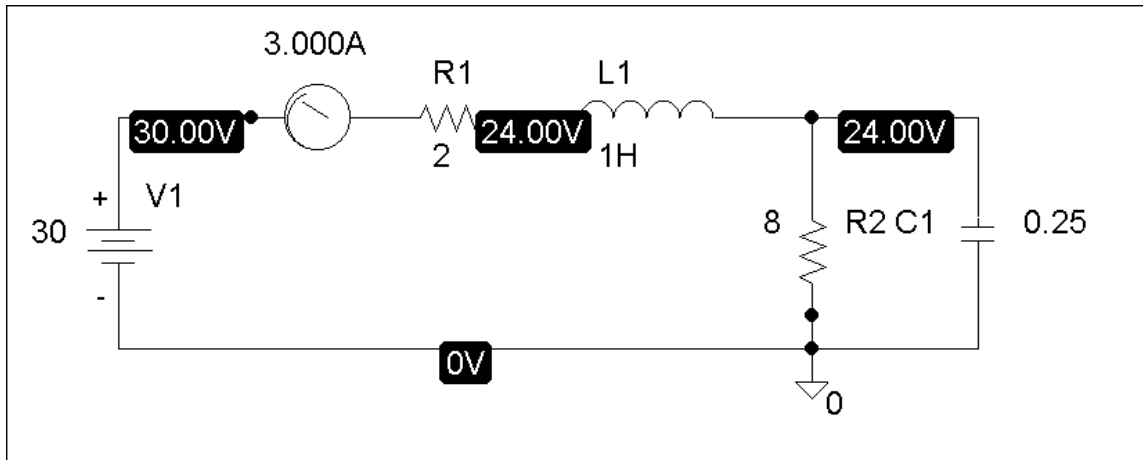

(b) For $t > 0$, we have the schematic shown below. To display $i(t)$ and $v(t)$, we insert current and voltage markers as shown. The initial inductor current and capacitor voltage are also incorporated. In the Transient box, we set Print Step = 25 ms and the Final Time to 4s. After simulation, we automatically have $i_o(t)$ and $v_o(t)$ displayed as shown below.

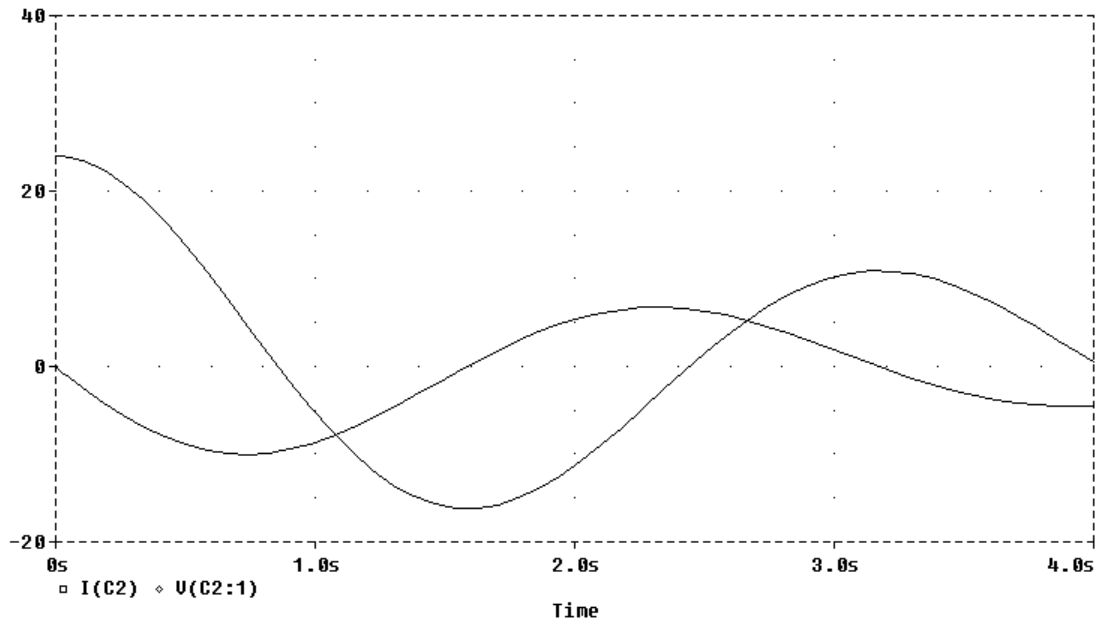
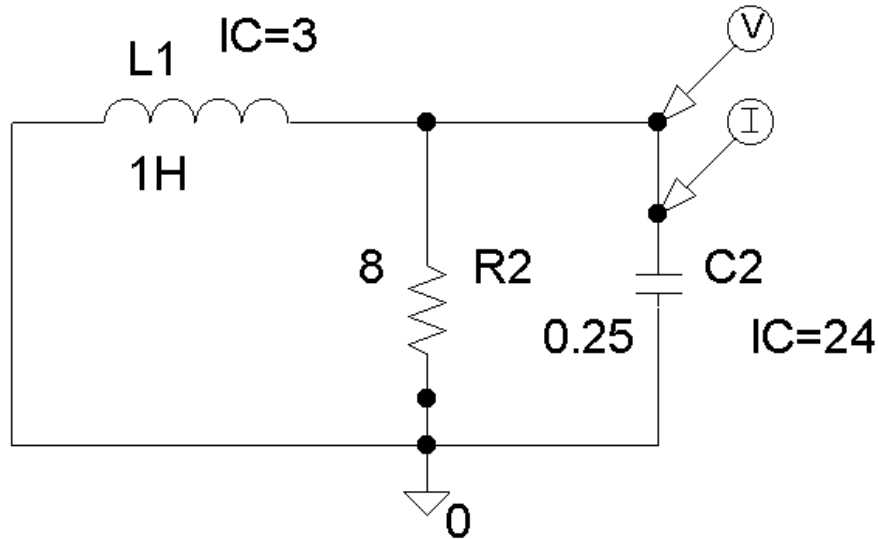

PROPRIETARY MATERIAL. © 2007 The McGraw-Hill Companies, Inc. All rights reserved. No part of this Manual may be displayed, reproduced or distributed in any form or by any means, without the prior written permission of the publisher, or used beyond the limited distribution to teachers and educators permitted by McGraw-Hill for their individual course preparation. If you are a student using this Manual, you are using it without permission.

Chapter 8, Problem 74.

The dual is constructed as shown in Fig. 8.118(a). The dual is redrawn as shown in Fig. 8.118(b).

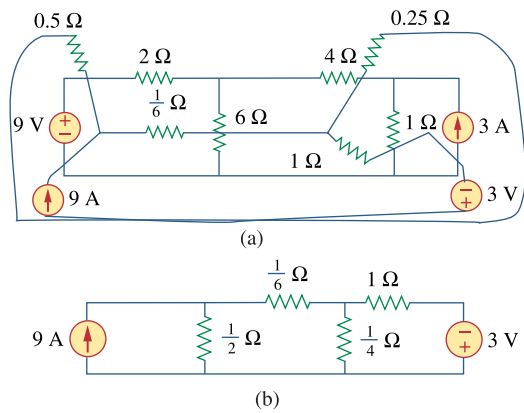
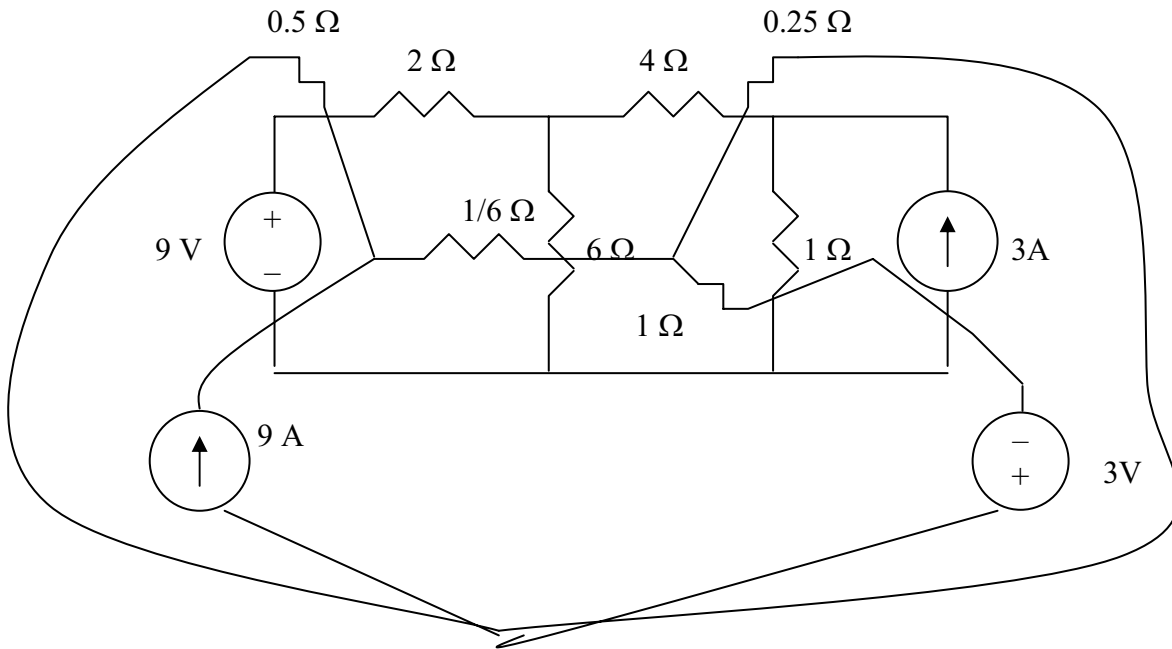

Figure 8.118
For Prob. 8.74.

Chapter 8, Solution 74.

The dual is constructed as shown below.



The dual is redrawn as shown below.

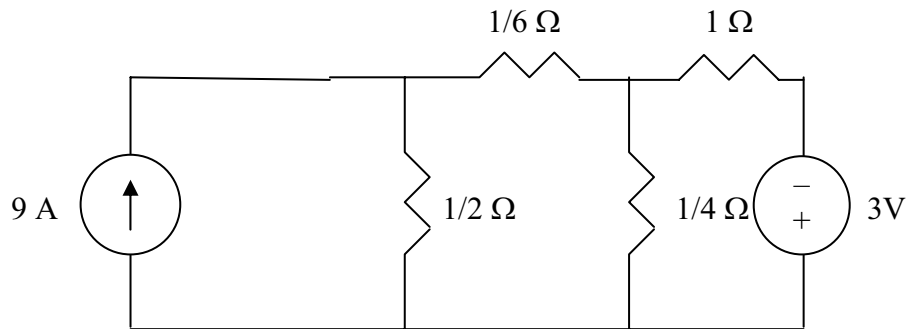

Chapter 8, Problem 75.

Obtain the dual of the circuit in Fig. 8.119.

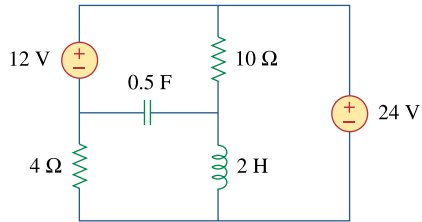
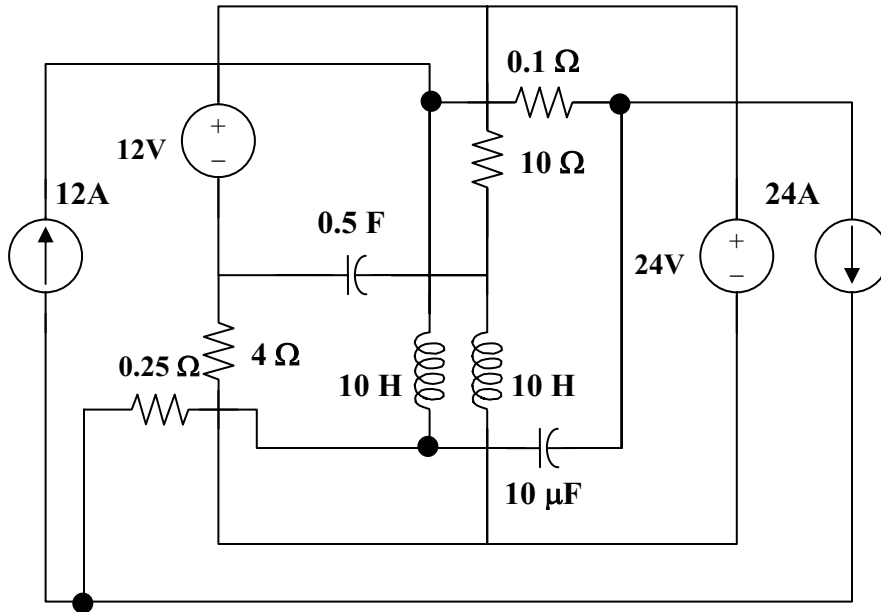

Figure 8.119
For Prob. 8.75.

Chapter 8, Solution 75.

The dual circuit is connected as shown in Figure (a). It is redrawn in Figure (b).



(a)

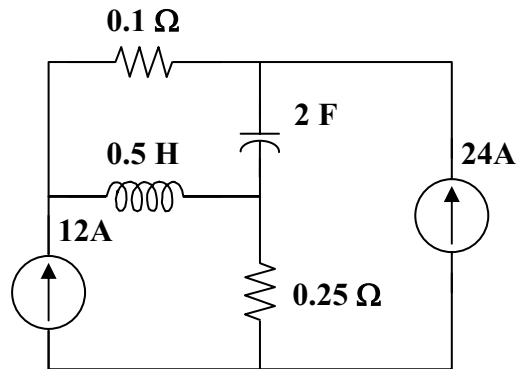

(b)

Chapter 8, Problem 76.

Find the dual of the circuit in Fig. 8.120.

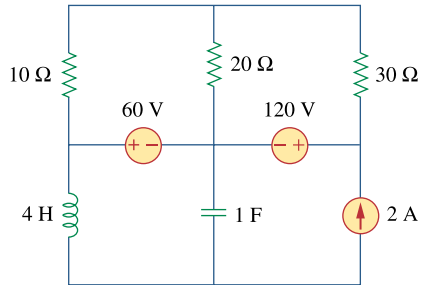
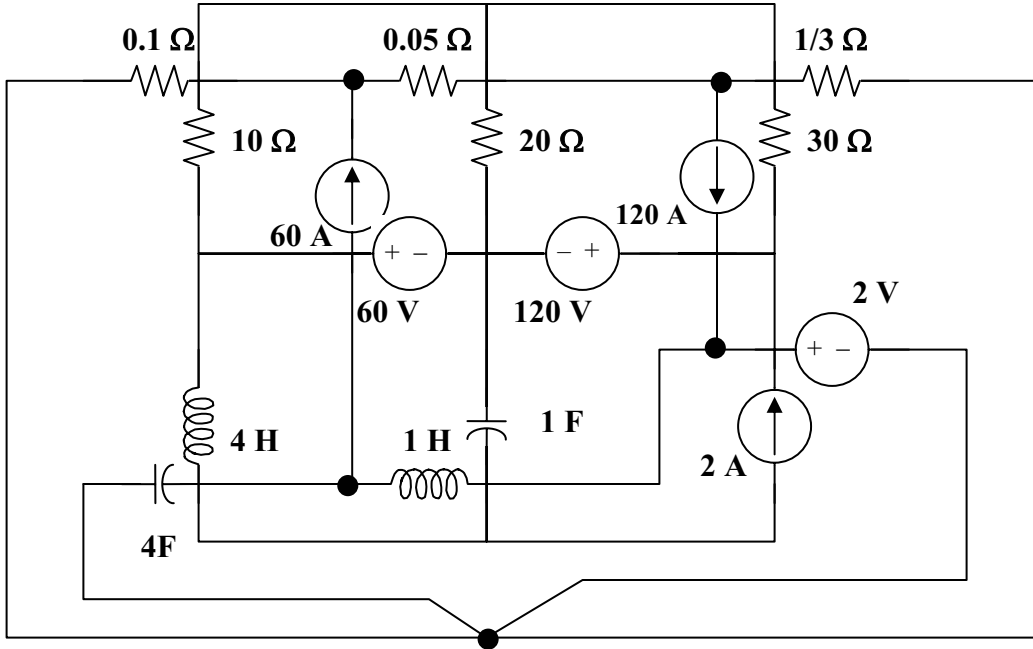

Figure 8.120
For Prob. 8.76.

Chapter 8, Solution 76.

The dual is obtained from the original circuit as shown in Figure (a). It is redrawn in Figure (b).



(a)

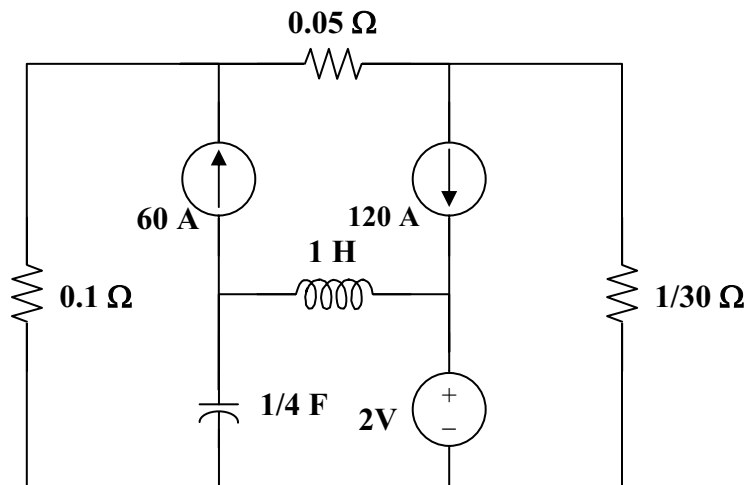

(b)

Chapter 8, Problem 77.

Draw the dual of the circuit in Fig. 8.121.

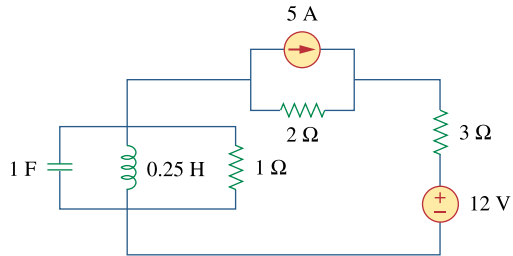
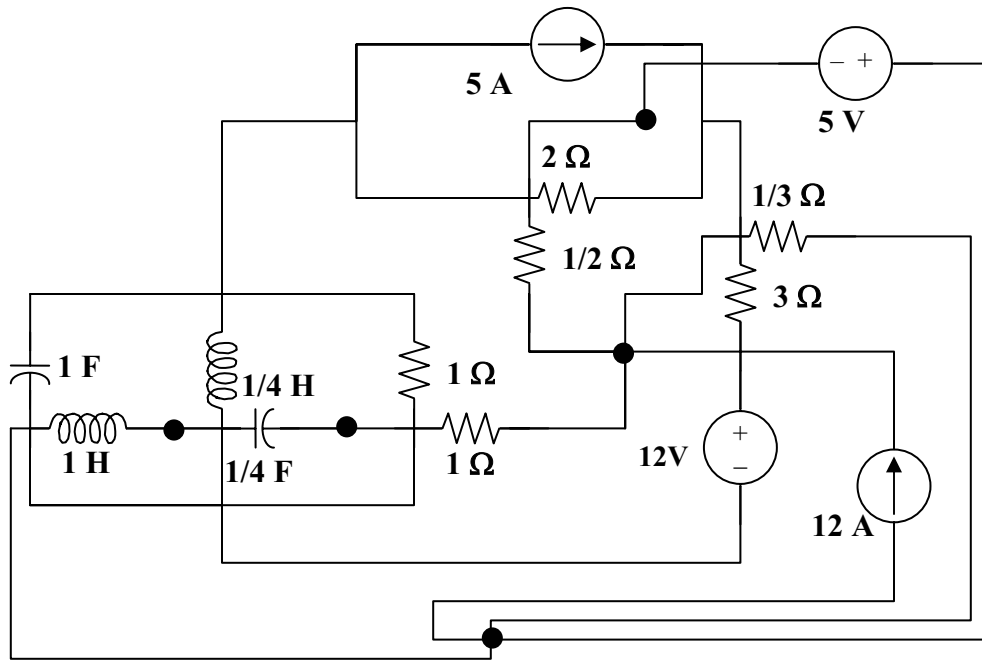

Figure 8.121
For Prob. 8.77.

Chapter 8, Solution 77.

The dual is constructed in Figure (a) and redrawn in Figure (b).



(a)

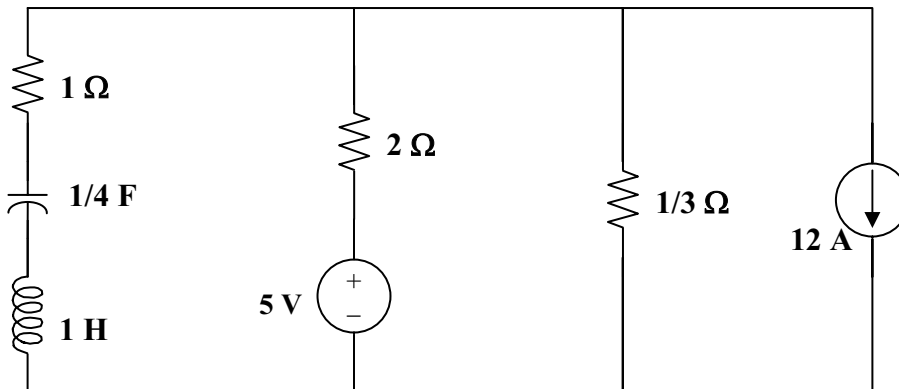

(b)

Chapter 8, Problem 78.

An automobile airbag igniter is modeled by the circuit in Fig. 8.122. Determine the time it takes the voltage across the igniter to reach its first peak after switching from A to B . Let $R = 3\Omega$, $C = 1/30\text{ F}$, and $L = 60\text{ mH}$.

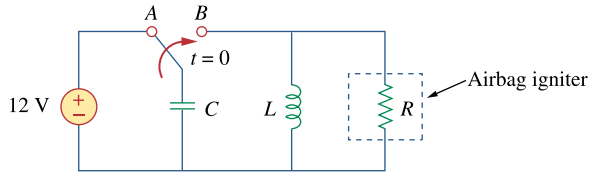

Figure 8.122
For Prob. 8.78.

Chapter 8, Solution 78.

The voltage across the igniter is $v_R = v_C$ since the circuit is a parallel RLC type.

$$v_C(0) = 12, \text{ and } i_L(0) = 0.$$

$$\alpha = 1/(2RC) = 1/(2 \times 3 \times 1/30) = 5$$

$$\omega_o = 1/\sqrt{LC} = 1/\sqrt{60 \times 10^{-3} \times 1/30} = 22.36$$

$\alpha < \omega_o$ produces an underdamped response.

$$s_{1,2} = -\alpha \pm \sqrt{\alpha^2 - \omega_o^2} = -5 \pm j21.794$$

$$v_C(t) = e^{-5t}(A \cos 21.794t + B \sin 21.794t) \quad (1)$$

$$v_C(0) = 12 = A$$

$$\begin{aligned} dv_C/dt &= -5[(A \cos 21.794t + B \sin 21.794t)e^{-5t}] \\ &\quad + 21.794[-A \sin 21.794t + B \cos 21.794t]e^{-5t} \end{aligned} \quad (2)$$

$$dv_C(0)/dt = -5A + 21.794B$$

But, $dv_C(0)/dt = -[v_C(0) + Ri_L(0)]/(RC) = -(12 + 0)/(1/10) = -120$

Hence, $-120 = -5A + 21.794B$, leads to $B = (5 \times 12 - 120)/21.794 = -2.753$

At the peak value, $dv_C(t_o)/dt = 0$, i.e.,

$$0 = A + B \tan 21.794t_o + (A21.794/5) \tan 21.794t_o - 21.794B/5$$

$$(B + A21.794/5) \tan 21.794t_o = (21.794B/5) - A$$

$$\tan 21.794t_o = [(21.794B/5) - A]/(B + A21.794/5) = -24/49.55 = -0.484$$

Therefore, $21.794t_o = |-0.451|$

$$t_o = |-0.451|/21.794 = \mathbf{20.68 \text{ ms}}$$

Chapter 8, Problem 79.

A load is modeled as a 250-mH inductor in parallel with a 12- Ω resistor. A capacitor is needed to be connected to the load so that the network is critically damped at 60 Hz. Calculate the size of the capacitor.

Chapter 8, Solution 79.

For critical damping of a parallel RLC circuit,

$$\alpha = \omega_o \quad \longrightarrow \quad \frac{1}{2RC} = \frac{1}{\sqrt{LC}}$$

Hence,

$$C = \frac{L}{4R^2} = \frac{0.25}{4 \times 144} = \underline{434 \mu\text{F}}$$

Chapter 8, Problem 80.



A mechanical system is modeled by a series RLC circuit. It is desired to produce an overdamped response with time constants 0.1 ms and 0.5 ms. If a series 50-k Ω resistor is used, find the values of L and C .

Chapter 8, Solution 80.

$$t_1 = 1/|s_1| = 0.1 \times 10^{-3} \text{ leads to } s_1 = -1000/0.1 = -10,000$$

$$t_2 = 1/|s_2| = 0.5 \times 10^{-3} \text{ leads to } s_2 = -2,000$$

$$s_1 = -\alpha - \sqrt{\alpha^2 - \omega_0^2}$$

$$s_2 = -\alpha + \sqrt{\alpha^2 - \omega_0^2}$$

$$s_1 + s_2 = -2\alpha = -12,000, \text{ therefore } \alpha = 6,000 = R/(2L)$$

$$L = R/12,000 = 50,000/12,000 = \mathbf{4.167H}$$

$$s_2 = -\alpha + \sqrt{\alpha^2 - \omega_0^2} = -2,000$$

$$\alpha - \sqrt{\alpha^2 - \omega_0^2} = 2,000$$

$$6,000 - \sqrt{\alpha^2 - \omega_0^2} = 2,000$$

$$\sqrt{\alpha^2 - \omega_0^2} = 4,000$$

$$\alpha^2 - \omega_0^2 = 16 \times 10^6$$

$$\omega_0^2 = \alpha^2 - 16 \times 10^6 = 36 \times 10^6 - 16 \times 10^6$$

$$\omega_0 = 10^3 \sqrt{20} = 1/\sqrt{LC}$$

$$C = 1/(20 \times 10^6 \times 4.167) = \mathbf{12 \text{ nF}}$$

Chapter 8, Problem 81.

e2d

An oscillogram can be adequately modeled by a second-order system in the form of a parallel RLC circuit. It is desired to give an underdamped voltage across a $200\text{-}\Omega$ resistor. If the damping frequency is 4 kHz and the time constant of the envelope is 0.25 s , find the necessary values of L and C .

Chapter 8, Solution 81.

$$t = 1/\alpha = 0.25 \text{ leads to } \alpha = 4$$

But, $\alpha = 1/(2RC)$ or, $C = 1/(2\alpha R) = 1/(2 \times 4 \times 200) = \underline{\underline{625\ \mu\text{F}}}$

$$\omega_d = \sqrt{\omega_o^2 - \alpha^2}$$

$$\omega_o^2 = \omega_d^2 + \alpha^2 = (2\pi \times 4 \times 10^3)^2 + 16 \cong (2\pi \times 4 \times 10^3)^2 = 1/(LC)$$

This results in $L = 1/(64\pi^2 \times 10^6 \times 625 \times 10^{-6}) = \underline{\underline{2.533\ \mu\text{H}}}$

Chapter 8, Problem 82.

The circuit in Fig. 8.123 is the electrical analog of body functions used in medical schools to study convulsions. The analog is as follows:

C_1 = Volume of fluid in a drug

C_2 = Volume of blood stream in a specified region

R_1 = Resistance in the passage of the drug from the input to the blood stream

R_2 = Resistance of the excretion mechanism, such as kidney, etc.

v_0 = Initial concentration of the drug dosage

$v(t)$ = Percentage of the drug in the blood stream

Find $v(t)$ for $t > 0$ given that $C_1 = 0.5\mu\text{F}$, $C_2 = 5\mu\text{F}$, $R_1 = 5\text{M}\Omega$, and $v_0 = 60u(t)\text{V}$.

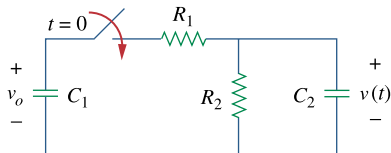

Figure 8.123

For Prob. 8.82.

Chapter 8, Solution 82.

For $t = 0^-$, $v(0) = 0$.

For $t > 0$, the circuit is as shown below.

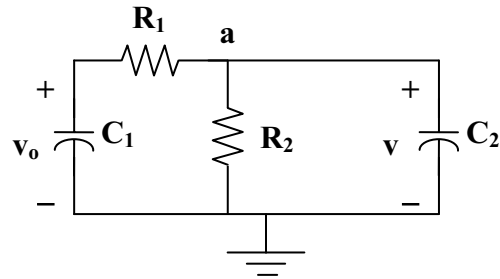

At node a,

$$(v_o - v)/R_1 = (v/R_2) + C_2 dv/dt$$

$$v_o = v(1 + R_1/R_2) + R_1 C_2 dv/dt$$

$$60 = (1 + 5/2.5) + (5 \times 10^6 \times 5 \times 10^{-6}) dv/dt$$

$$60 = 3v + 25 dv/dt$$

$$v(t) = V_s + [Ae^{-3t/25}]$$

where $3V_s = 60$ yields $V_s = 20$

$$v(0) = 0 = 20 + A \text{ or } A = -20$$

$$v(t) = \underline{\underline{20(1 - e^{-3t/25})V}}$$

Chapter 8, Problem 83.

e2d

Figure 8.124 shows a typical tunnel-diode oscillator circuit. The diode is modeled as a nonlinear resistor with $i_D = f(v_D)$ i.e., the diode current is a nonlinear function of the voltage across the diode. Derive the differential equation for the circuit in terms of v and i_D .

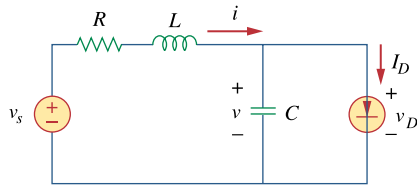

Figure 8.124
For Prob. 8.83.

Chapter 8, Solution 83.

$$i = i_D + Cdv/dt \quad (1)$$

$$-v_s + iR + Ldi/dt + v = 0 \quad (2)$$

Substituting (1) into (2),

$$v_s = Ri_D + RCdv/dt + Ldi_D/dt + LCd^2v/dt^2 + v = 0$$

$$LCd^2v/dt^2 + RCdv/dt + Ri_D + Ldi_D/dt = v_s$$

$$\underline{\underline{d^2v/dt^2 + (R/L)dv/dt + (R/LC)i_D + (1/C)di_D/dt = v_s/LC}}$$