

# Review of AC Sinusoidal Circuits

Yahia Baghzouz

# Root Mean Square (rms) Value and Phasors

- Goal of phasor analysis is to simplify the analysis of constant frequency ac systems

$$v(t) = V_{\max} \cos(\omega t + \theta_v)$$

$$i(t) = I_{\max} \cos(\omega t + \theta_i)$$

- Root Mean Square (RMS) voltage of sinusoid

$$\sqrt{\frac{1}{T} \int_0^T v(t)^2 dt} = \frac{V_{\max}}{\sqrt{2}}$$

The RMS, cosine-referenced voltage phasor is:

$$V = |V| e^{j\theta_V} = |V| \angle \theta_V$$

$$v(t) = \operatorname{Re} \sqrt{2} V e^{j\omega t} e^{j\theta_V}$$

$$V = |V| \cos \theta_V + j |V| \sin \theta_V$$

$$I = |I| \cos \theta_I + j |I| \sin \theta_I$$

# Impedance of linear elements

## Device

## Time Analysis

## Phasor

Resistor

$$v(t) = Ri(t)$$

$$V = RI$$

Inductor

$$v(t) = L \frac{di(t)}{dt}$$

$$V = j\omega LI$$

Capacitor

$$\frac{1}{C} \int_0^t i(t) dt + v(0)$$

$$V = \frac{1}{j\omega C} I$$

$$Z = \text{Impedance} = R + jX = |Z| \angle \phi$$

$$R = \text{Resistance}$$

$$X = \text{Reactance}$$

$$|Z| = \sqrt{R^2 + X^2} \quad \phi = \arctan\left(\frac{X}{R}\right)$$

# Instantaneous and Average Power, Power Factor

## Instantaneous Power

$$p(t) = v(t) i(t)$$

$$v(t) = V_{\max} \cos(\omega t + \theta_V)$$

$$i(t) = I_{\max} \cos(\omega t + \theta_I)$$

$$p(t) = \frac{1}{2} V_{\max} I_{\max} [\cos(\theta_V - \theta_I) + \cos(2\omega t + \theta_V + \theta_I)]$$

$$P_{avg} = \frac{1}{T} \int_0^T p(t) dt$$

$$= \frac{1}{2} V_{\max} I_{\max} \cos(\theta_V - \theta_I)$$

$$= |V| |I| \cos(\theta_V - \theta_I)$$

$$\text{Power Factor Angle} = \phi = \theta_V - \theta_I$$

# Pure Resistive Load

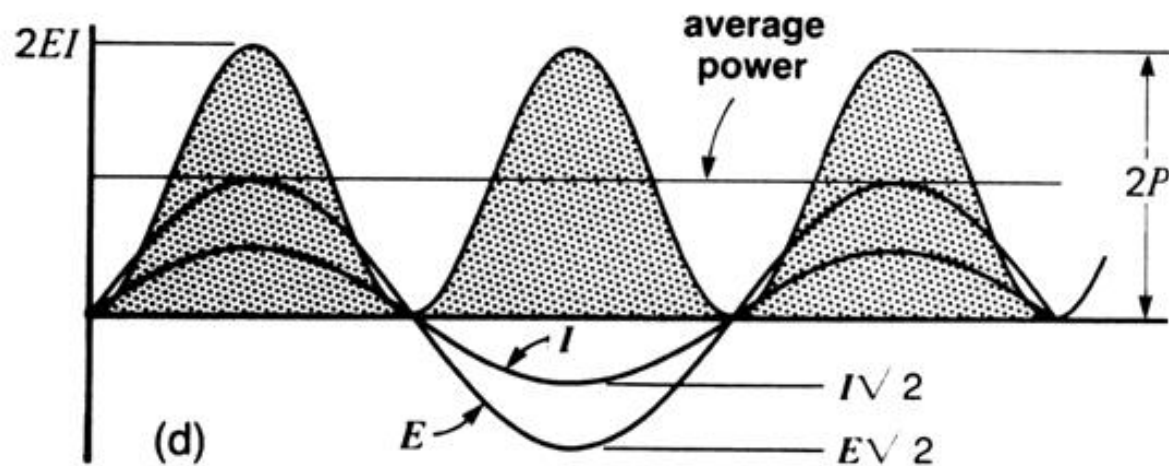
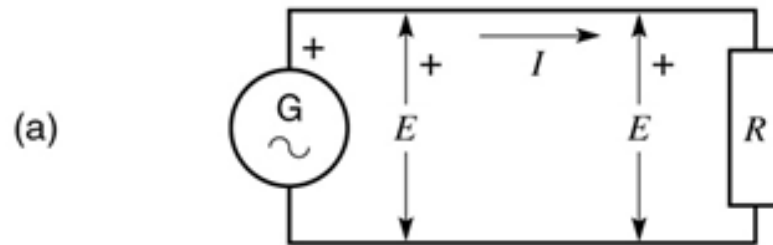

# Pure Inductive Load

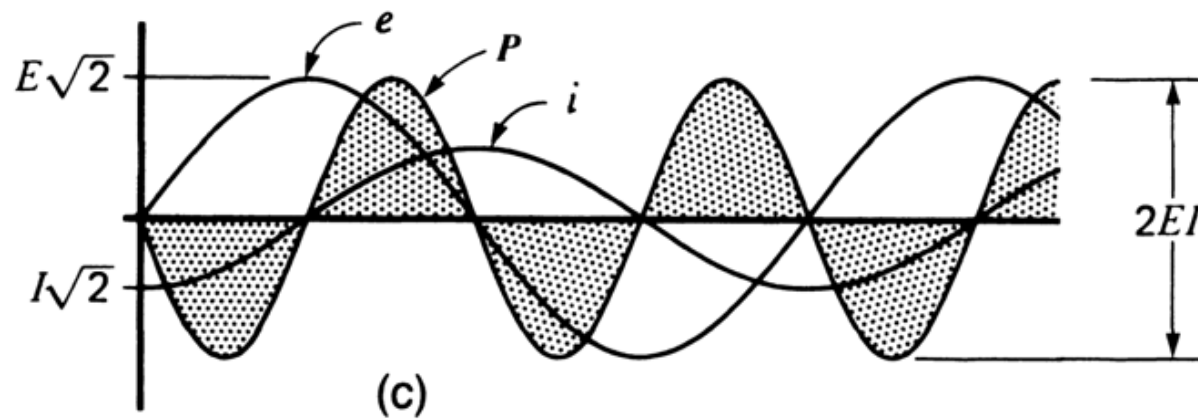
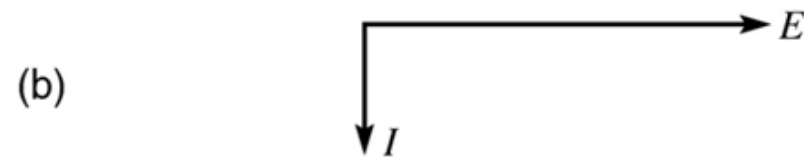
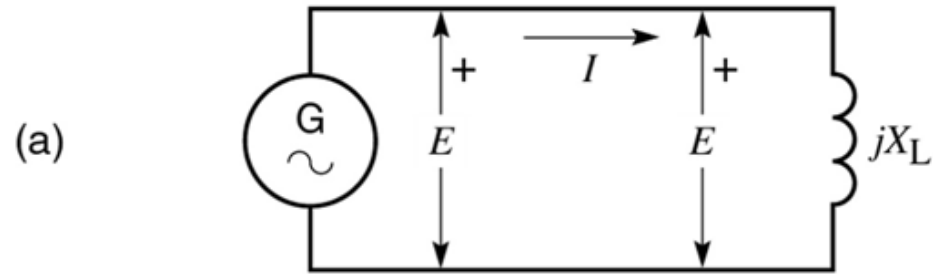

# Resistive-Inductive and resistive-capacitive Load

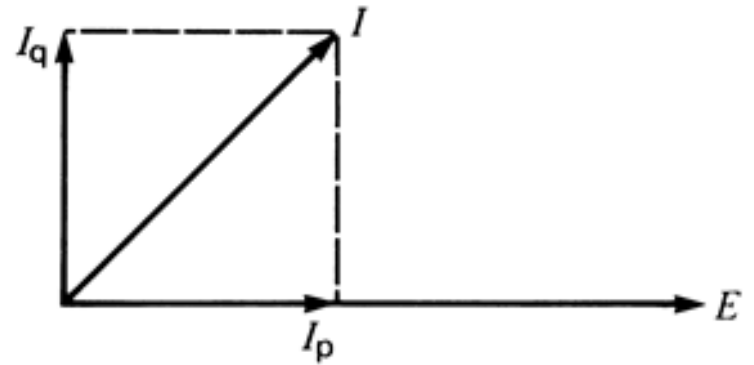
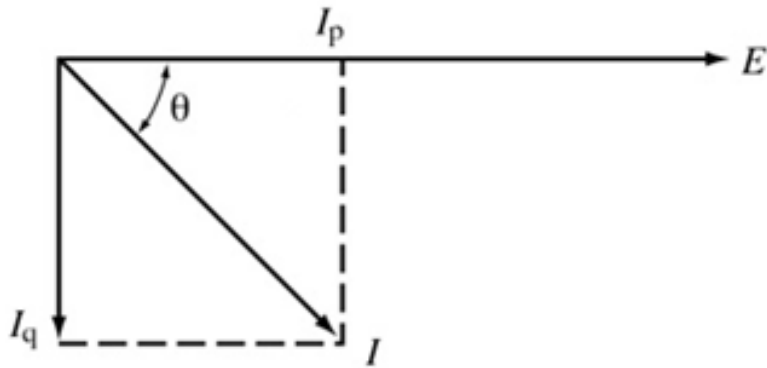
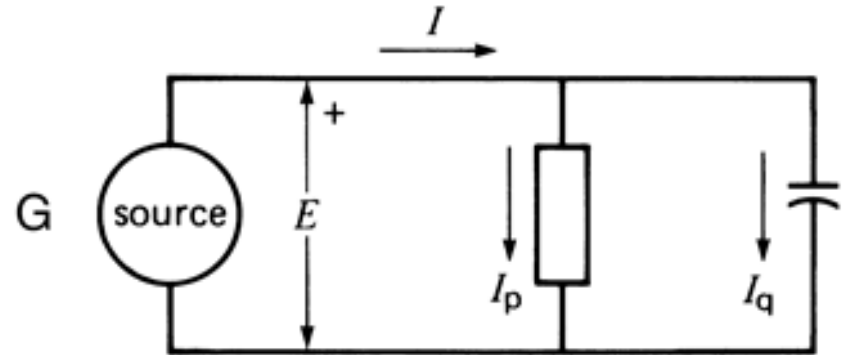
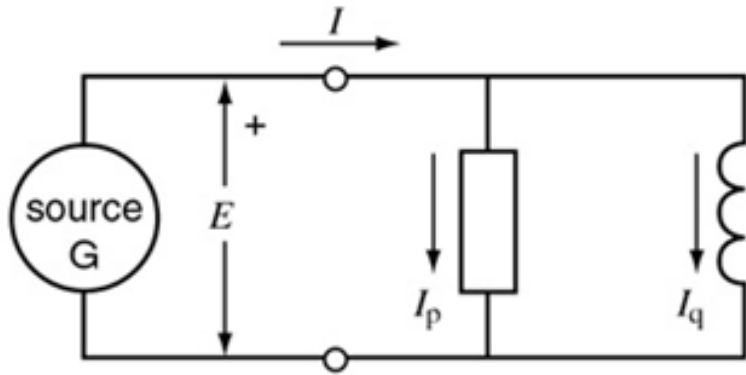

# Example: analyzing AC circuits with phasors

Find the instantaneous current  $i(t)$ , and the instantaneous Voltages across the resistor and inductor.

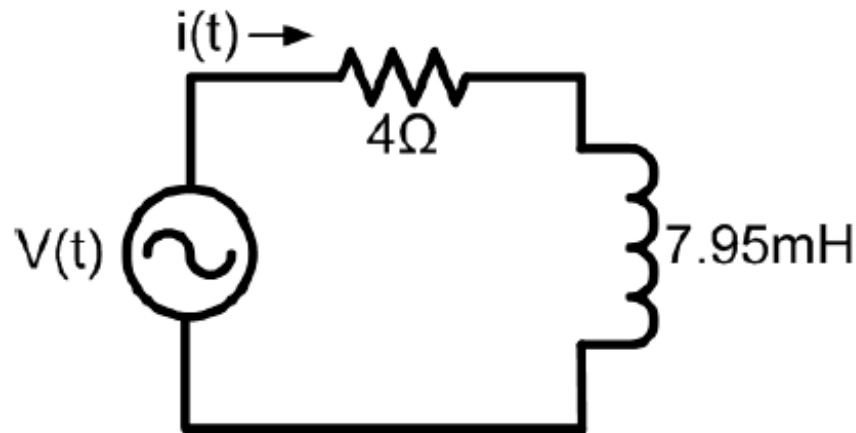

$$V(t) = \sqrt{2} 100 \cos(\omega t + 30^\circ)$$

$$f = 60\text{Hz}$$

$$R = 4\Omega \quad X = \omega L = 3$$

$$|Z| = \sqrt{4^2 + 3^2} = 5 \quad \phi = 36.9^\circ$$

$$\begin{aligned} I &= \frac{V}{Z} = \frac{100 \angle 30^\circ}{5 \angle 36.9^\circ} \\ &= 20 \angle -6.9^\circ \text{ Amps} \end{aligned}$$

$$i(t) = 20\sqrt{2} \cos(\omega t - 6.9^\circ)$$



# Complex Power, Apparent Power and Reactive Power

$$S = |V||I|[\cos(\theta_V - \theta_I) + j \sin(\theta_V - \theta_I)]$$

$$= P + jQ$$

$$= V I^*$$

(Note: S is a complex number but not a phasor)

P = Real Power (W, kW, MW)

Q = Reactive Power (var, kvar, Mvar)

S = Complex power (VA, kVA, MVA)

Power Factor (pf) =  $\cos \phi$

If current leads voltage then pf is leading

If current lags voltage then pf is lagging

$$P = |S| \cos \phi$$

$$Q = |S| \sin \phi = \pm |S| \sqrt{1 - pf^2}$$

$$|S| = |V||I| = (P^2 + Q^2)^{1/2} = \text{Apparent Power}$$

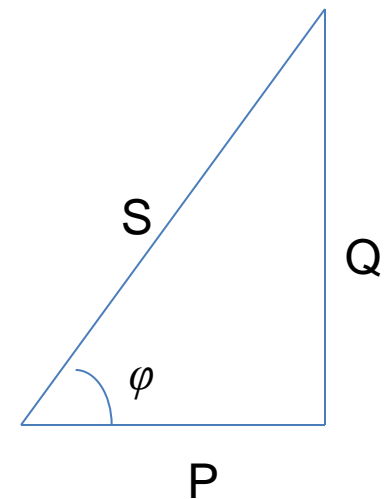

Power Triangle

# Power Consumption of Linear Circuit Elements

- Resistors only consume real power

$$P_{\text{Resistor}} = |I_{\text{Resistor}}|^2 R$$

- Inductors only consume reactive power

$$Q_{\text{Inductor}} = |I_{\text{Inductor}}|^2 X_L$$

- Capacitors only generate reactive power

$$Q_{\text{Capacitor}} = - |I_{\text{Capacitor}}|^2 X_C$$

# Power in inductive and capacitive circuits

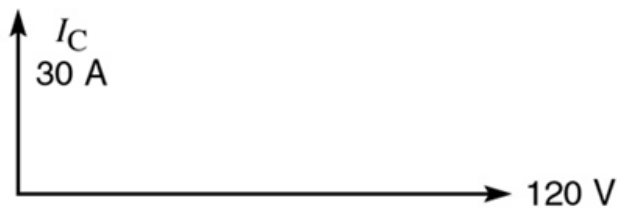
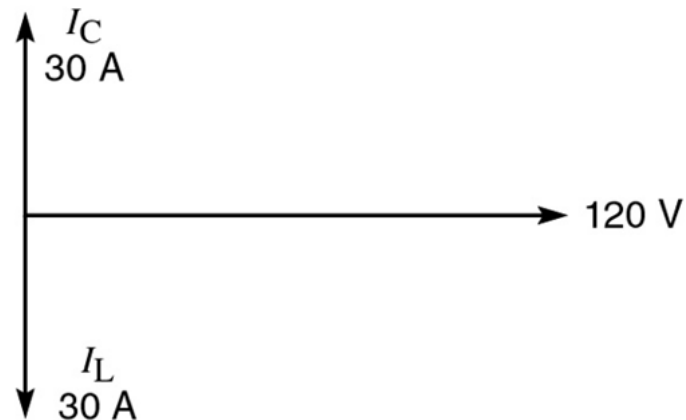
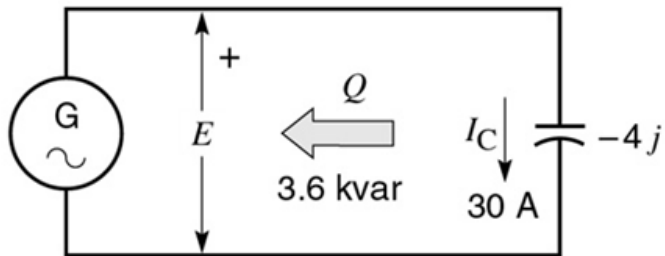
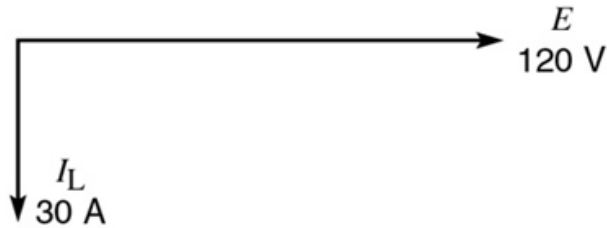
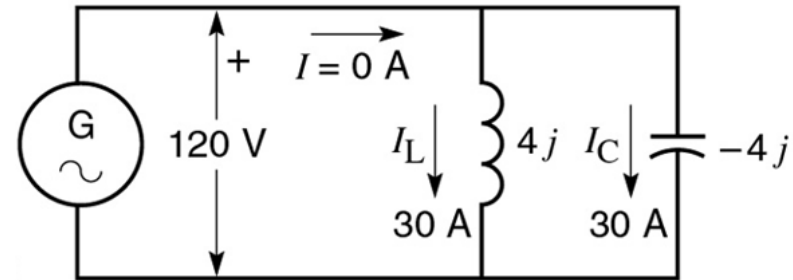
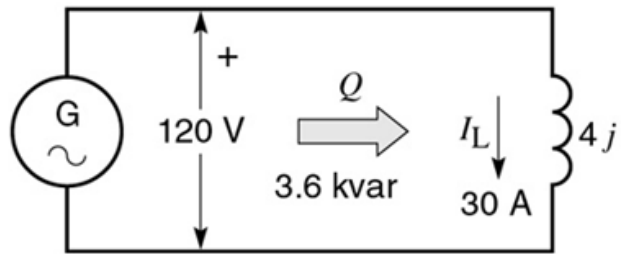

## Example: Active, Reactive, Apparent Power

Example: A load draws 100 kW with a leading pf of 0.85.  
What are  $\phi$  (power factor angle),  $Q$  and  $|S|$ ?

$$\phi = -\cos^{-1} 0.85 = -31.8^\circ$$

$$|S| = \frac{100 \text{ kW}}{0.85} = 117.6 \text{ kVA}$$

$$Q = 117.6 \sin(-31.8^\circ) = -62.0 \text{ kVar}$$

# Conservation of Power

- At every node (bus) in the system
  - Sum of real power into node must equal zero
  - Sum of reactive power into node must equal zero
- This is a direct consequence of Kirchhoff's current law, which states that the total current into each node must equal zero.
  - Conservation of power follows since  $S = VI^*$

## Example: active and reactive power generation

Find the real and reactive power generated by the source

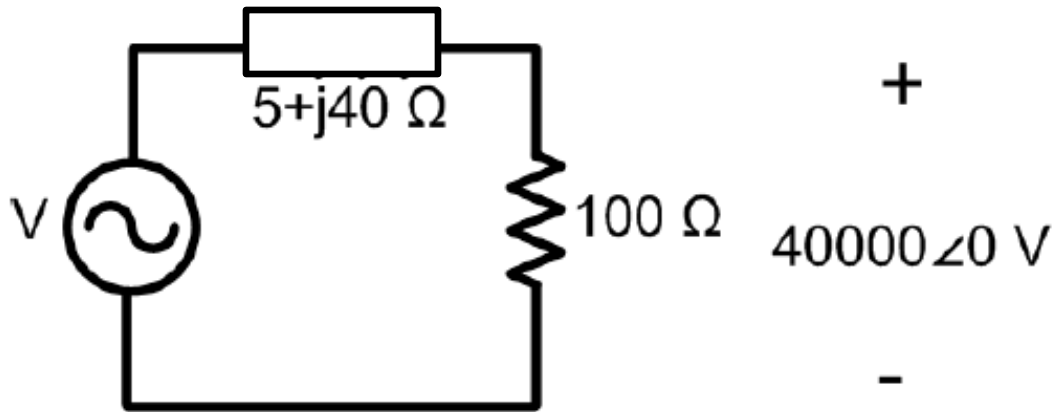

$$I = \frac{40000 \angle 0^\circ \text{ V}}{100 \angle 0^\circ \Omega} = 400 \angle 0^\circ \text{ Amps}$$

$$\begin{aligned} V &= 40000 \angle 0^\circ + (5 + j40) 400 \angle 0^\circ \\ &= 42000 + j16000 = 44.9 \angle 20.8^\circ \text{ kV} \end{aligned}$$

$$\begin{aligned} S &= VI^* = 44.9 \text{ k} \angle 20.8^\circ \times 400 \angle 0^\circ \\ &= 17.98 \angle 20.8^\circ \text{ MVA} = 16.8 + j6.4 \text{ MVA} \end{aligned}$$

## Example: active and reactive power generation

Find the real and reactive power generated by the source

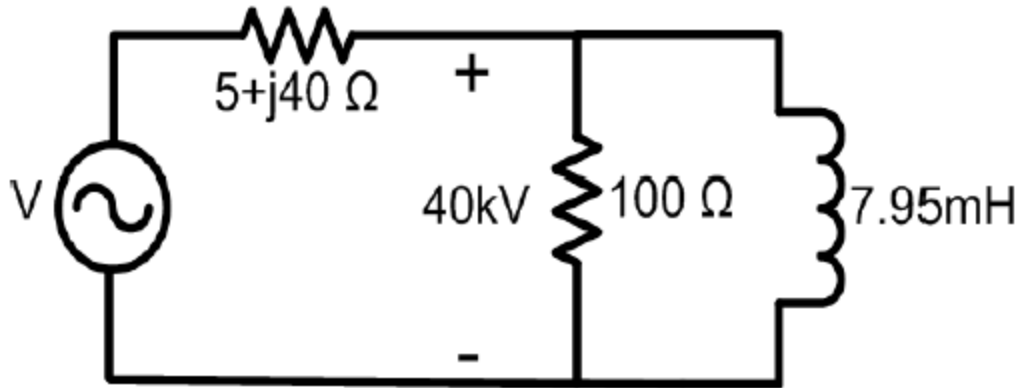

$$Z_{Load} = 70.7 \angle 45^\circ \quad pf = 0.7 \text{ lagging}$$

$$I = 564 \angle -45^\circ \text{ Amps}$$

$$V = 59.7 \angle 13.6^\circ \text{ kV}$$

$$S = 33.7 \angle 58.6^\circ \text{ MVA} = 17.6 + j28.8 \text{ MVA}$$

# Capacitors in Power Systems

Capacitors are used extensively in power systems to generate reactive power locally in order to correct the power factor, reduce the source current, regulate the voltage and improve system efficiency.





## Example: power factor correction

Assume we have 100 kVA load with  $\text{pf} = 0.8$  lagging, and would like to correct the pf to 0.95 lagging

$$S = 80 + j60 \text{ kVA} \quad \phi = \cos^{-1} 0.8 = 36.9^\circ$$

$$\text{pf of } 0.95 \text{ requires } \phi_{\text{desired}} = \cos^{-1} 0.95 = 18.2^\circ$$

$$S_{\text{new}} = 80 + j(60 - Q_{\text{cap}})$$

$$\frac{60 - Q_{\text{cap}}}{80} = \tan 18.2^\circ \Rightarrow 60 - Q_{\text{cap}} = 26.3 \text{ kvar}$$

$$Q_{\text{cap}} = 33.7 \text{ kvar}$$

# Example: Partial Power Factor Correction

Determine from the power triangle below the load power factor Before and after capacitor placement.

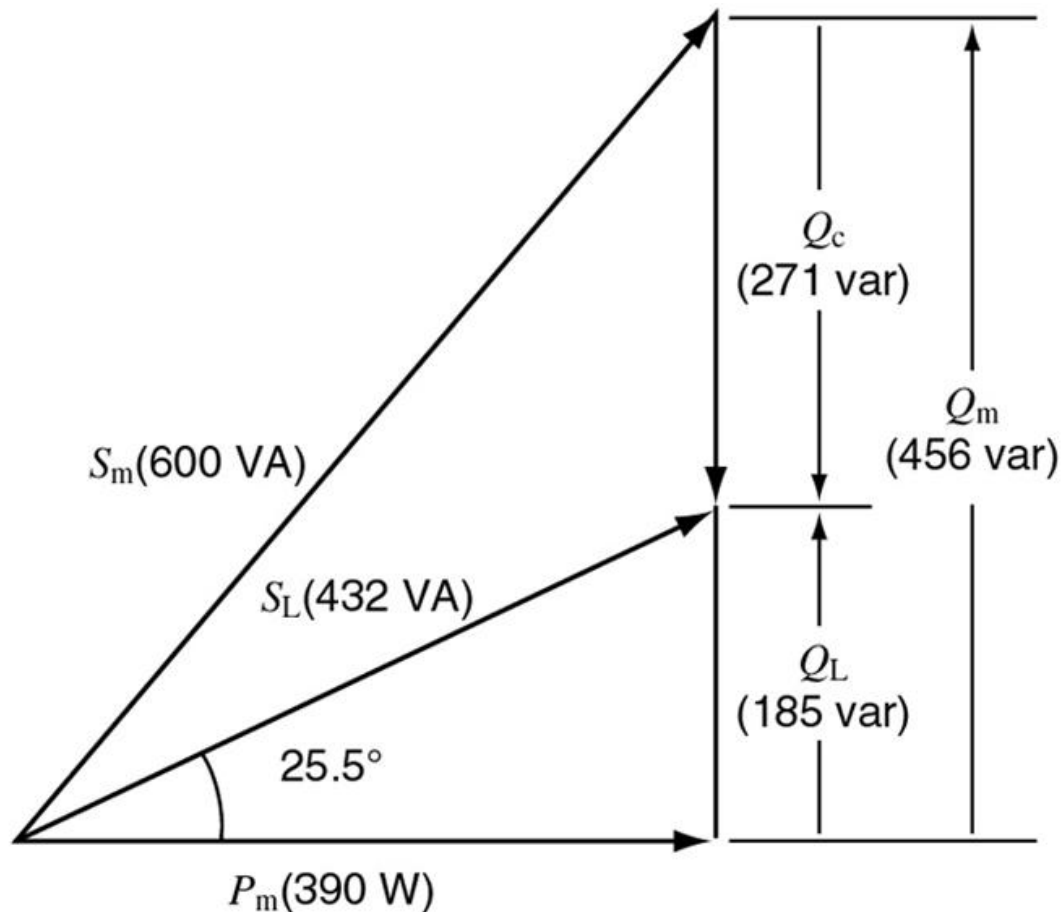

Problems (Chapter 1):  
18, 19,20