

Synchronous Generators II

EE 340



Generator P-f Curve

- All generators are driven by a prime mover, such as a steam, gas, water, wind turbines, diesel engines, etc.
- Regardless the power source, most of prime movers tend to slow down when increasing the load.
- The speed drop (SD) of the prime mover is defined as:

$$SD = \frac{n_{nl} - n_{fl}}{n_{fl}} \cdot 100\%$$

- Most prime movers have a speed drop from 2% to 4%. Most governors have a mechanism to adjust the turbine's no-load speed (set-point adjustment).

Generator P-f Curve

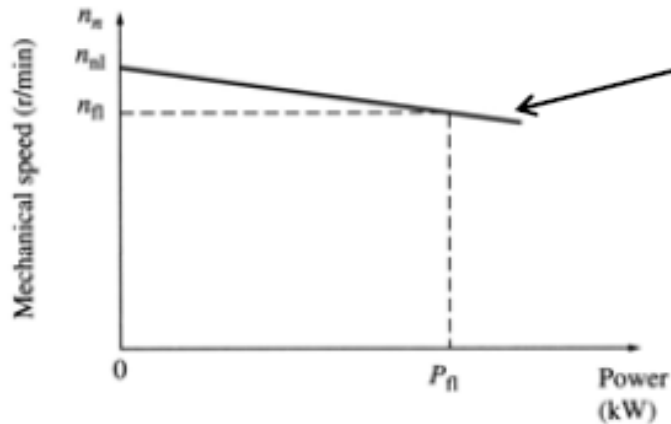

A typical speed vs. power plot

A typical frequency vs. power plot

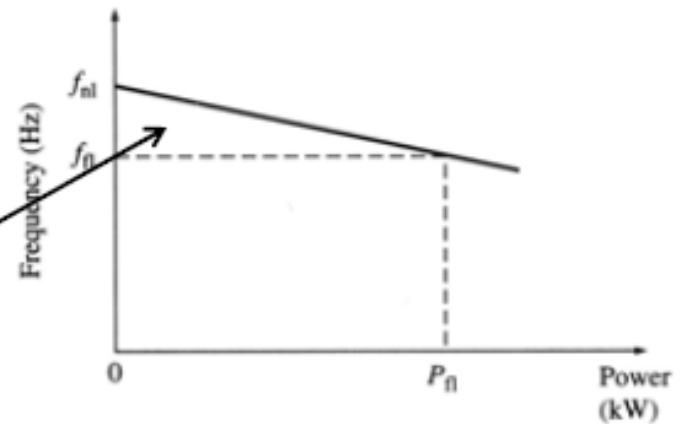

Since the shaft speed is connected to the electrical frequency as

$$f_e = \frac{n_m P}{120}$$

the power output from the generator is related to its frequency:

$$P = S_p (f_{nl} - f_{sys})$$

Slope of curve, W/Hz

Operating frequency of the system

Generator Q-V Curve

- A similar relationship can be derived for the reactive power Q and terminal voltage V_T .
 - When supplying a lagging load to a synchronous generator, its terminal voltage decreases.
 - When adding a leading load to a synchronous generator, its terminal voltage increases.

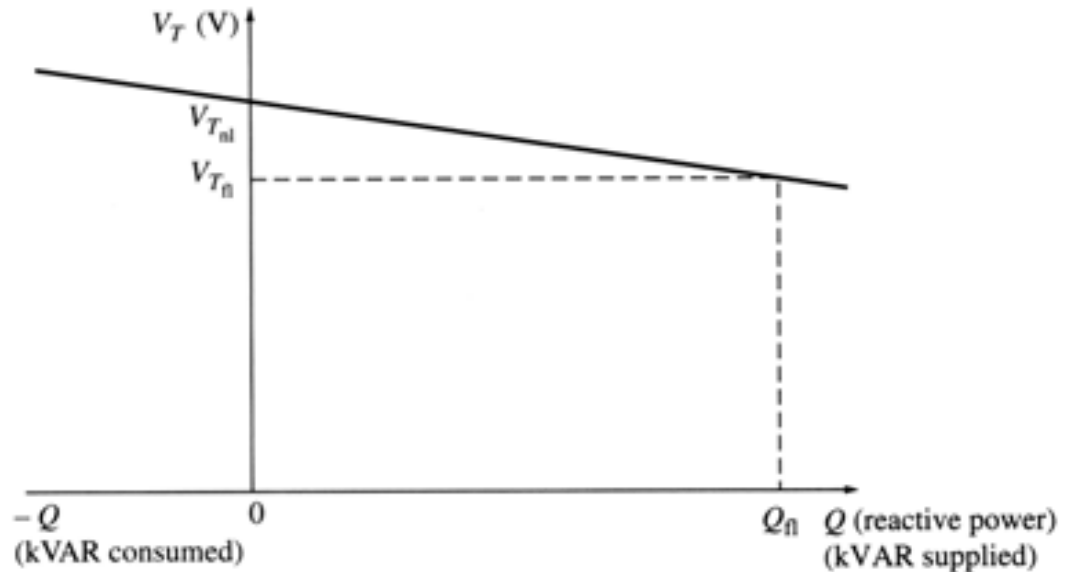

- Both the frequency-power and terminal voltage vs. reactive power characteristics are important for parallel operations of generators.

Example

A generator with no-load frequency of 61.0 Hz and a slope of 1 MW/Hz is connected to Load 1 consuming 1 MW of real power at 0.8 PF lagging. Load 2 (that to be connected to the generator) consumes a real power of 0.8 MW at 0.707 PF lagging.

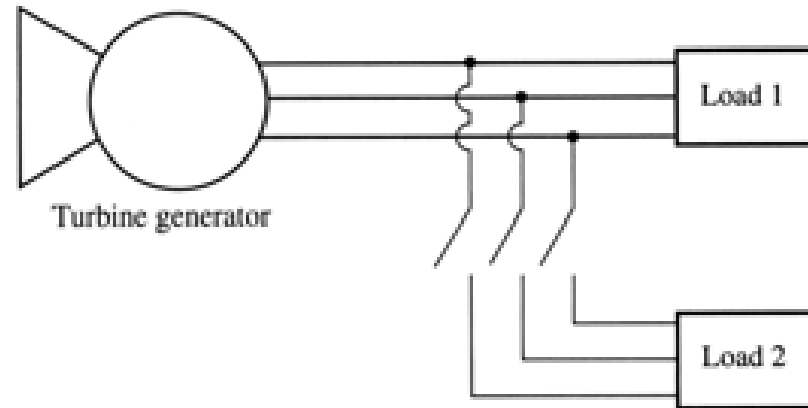

1. Find the operating frequency of the system before the switch is closed. (ans. 60 Hz)
2. Find the operating frequency of the system after the switch is closed. (ans. 59.2 Hz)
3. What action could an operator take to restore the system frequency to 60 Hz after both loads are connected to the generator? (ans. increase the governor no-load set point by 0.8 Hz)

Generators connected in parallel

- Most of synchronous generators are operating in parallel with other synchronous generators to supply power to the same power system.
- Obvious advantages of this arrangement are:
 - Several generators can supply a bigger load;
 - A failure of a single generator does not result in a total power loss to the load, thus increasing reliability of the power system;
 - Individual generators may be removed from the power system for maintenance without shutting down the load;
 - A single generator not operating at near full load might be quite inefficient. When having several generators in parallel, it is possible to turn off some, and operate the rest at near full-load condition.

Conditions required for paralleling generators

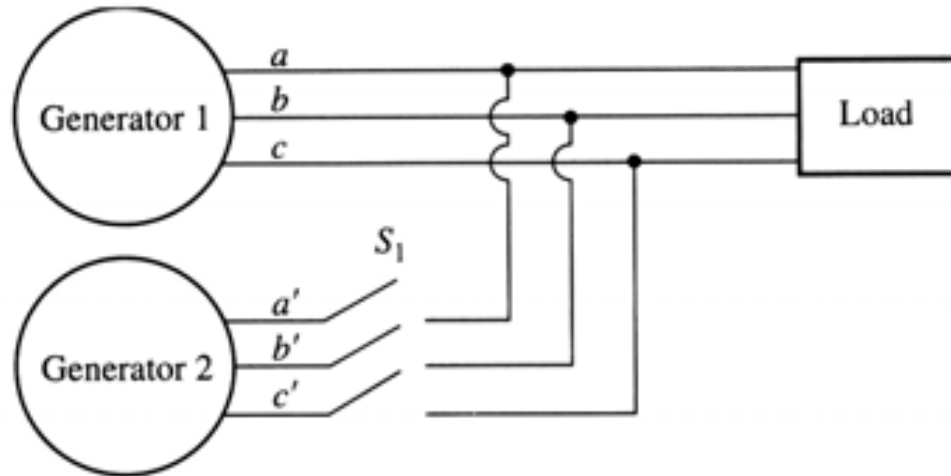

- Closing the switch **arbitrarily** can cause severe damage. If voltages are not the same (magnitude, frequency, phase, sequence) in both lines, a very large current will flow when the switch is closed.
- To avoid this, the following conditions must be met:
 - The rms line voltages of the two generators must be equal.
 - The two generators must have the same phase sequence.
 - The phase angles of two “ a ” phases must be equal.
 - The frequency of the oncoming generator must be slightly higher than the frequency of the running system.

Steps for paralleling generators (3-light bulb method)

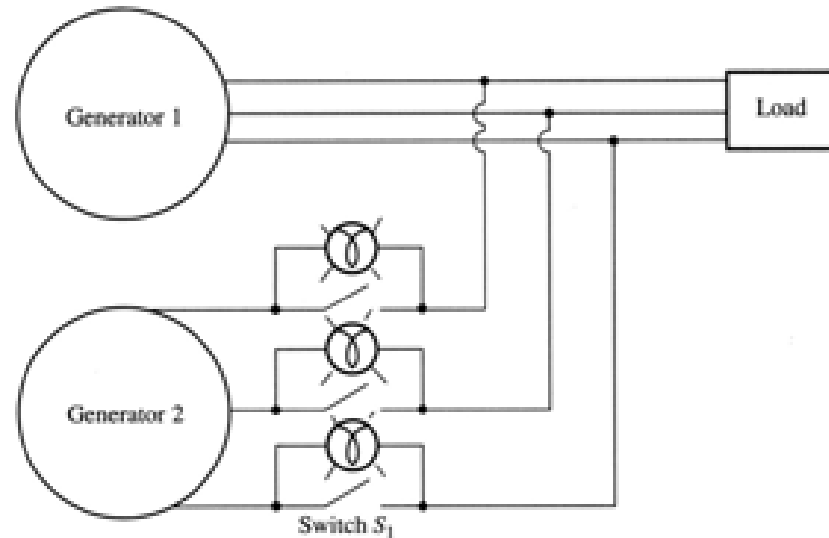

1. Adjust the field current of the oncoming generator to make its terminal voltage equal to the line voltage of the system (use a voltmeter).
2. Compare the phase sequences of the oncoming generator and the running system by examining the three light bulbs. If all three bulbs get bright and dark together, both generators have the same phase sequences. If not, two of the conductors must be altered.
3. The frequency of the oncoming generator is adjusted to be slightly higher than the system's frequency.
4. When all three lights go out, the voltage across them is zero and, therefore, machines are in phase. This is the time to close the switch.

Synchronizing a generator with the utility grid

- When a synchronous generator is added to a power system, that system is so large that one additional generator does not cause observable changes to the system.
- An **infinite bus** is a power system that is so large that its voltage and frequency do not vary regardless of how much real and reactive power is drawn from or supplied to it (i.e., the power-frequency and reactive power-voltage characteristics are horizontal:

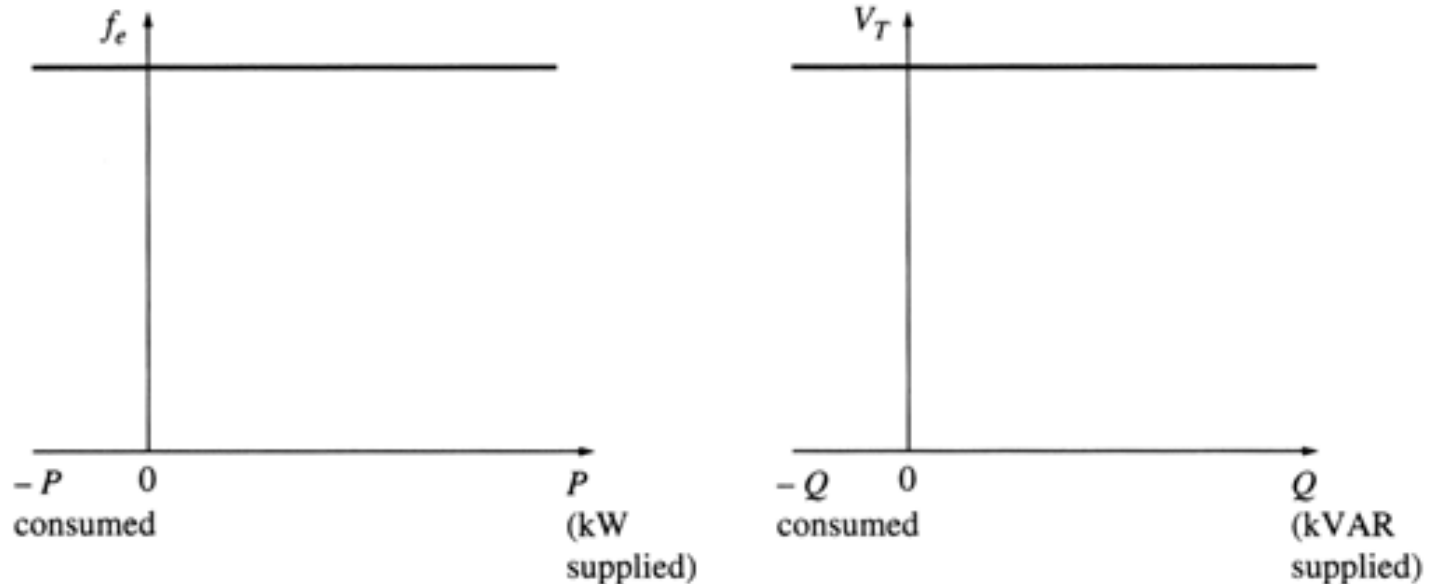

Synchronizing a generator with the utility grid

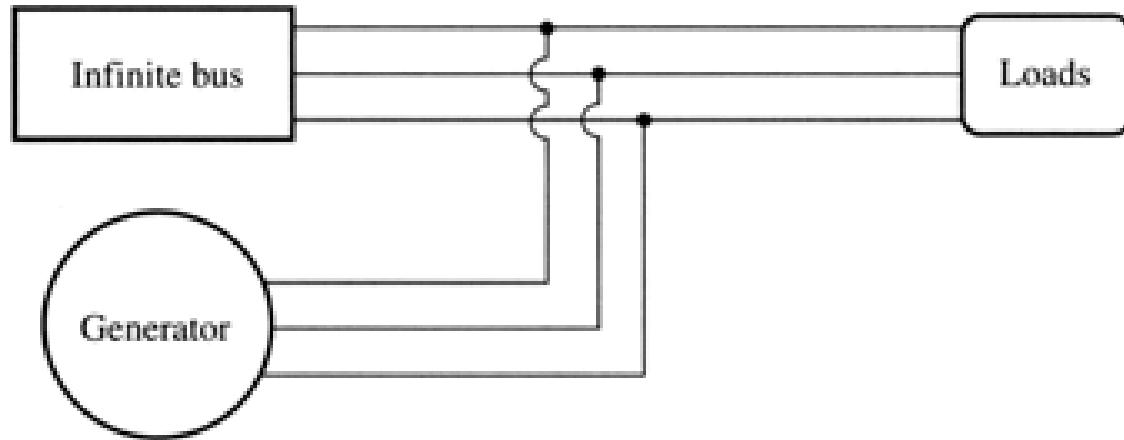

- Consider adding a generator to an infinite bus supplying a load.
- The frequency and terminal voltage of all machines must be the same.
- Therefore, their power-frequency and reactive power-voltage characteristics can be plotted with a common vertical axis.

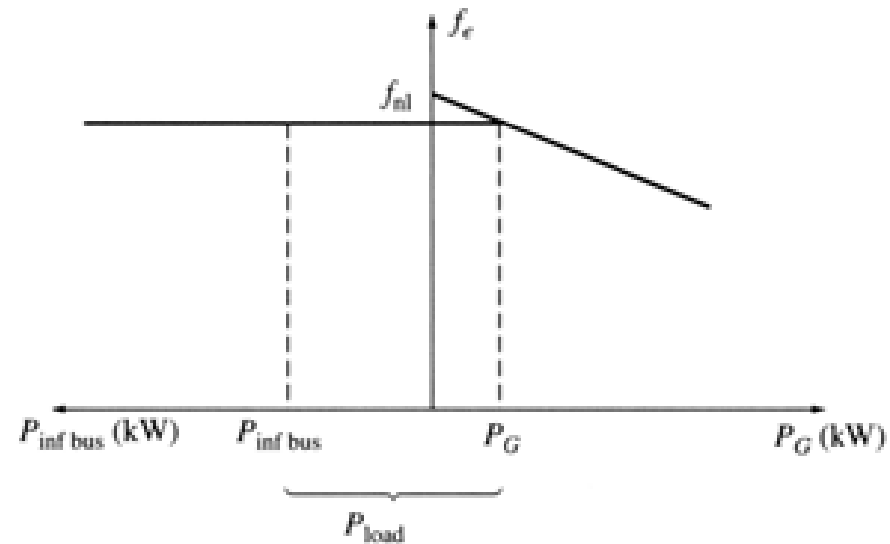

Synchronizing a generator with the utility grid

If the no-load frequency of the oncoming generator is slightly higher than the system's frequency, the generator will be "floating" on the line supplying a small amount of real power and little or no reactive power.

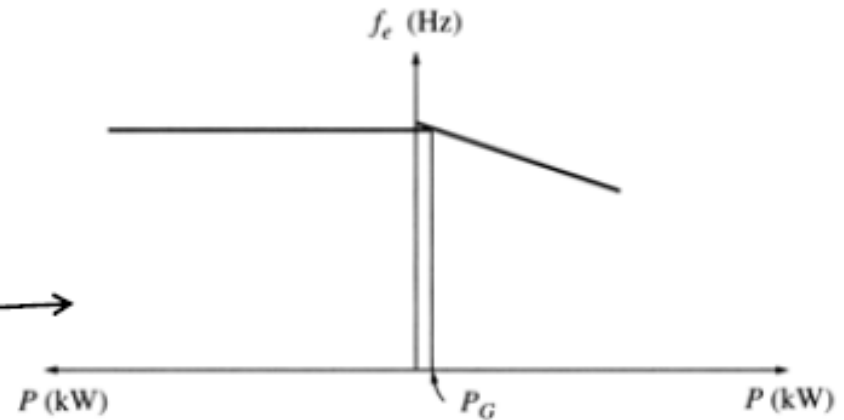

If the no-load frequency of the oncoming generator is slightly lower than the system's frequency, the generator will supply a negative power to the system: the generator actually consumes energy acting as a motor!

Many generators have circuitry automatically disconnecting them from the line when they start consuming energy.

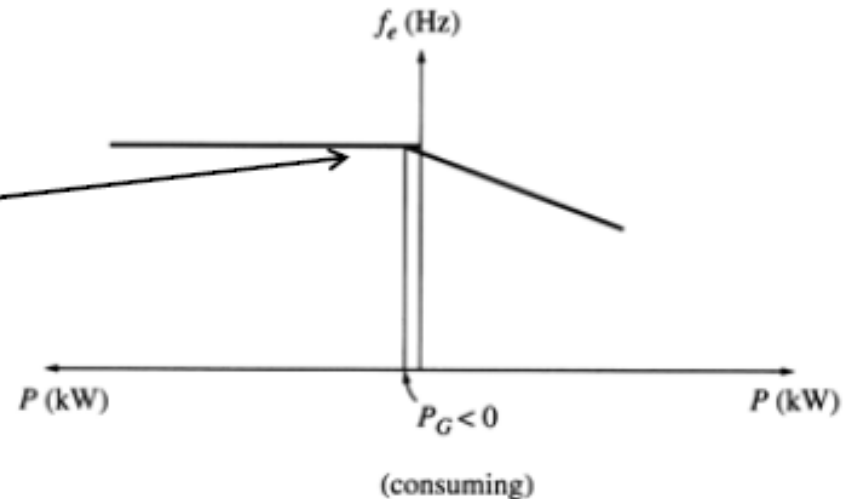

Parallel operation with the utility grid

- If an attempt is made to increase the speed of the generator after it is connected to the infinite bus, the system frequency cannot change and the power supplied by the generator increases.

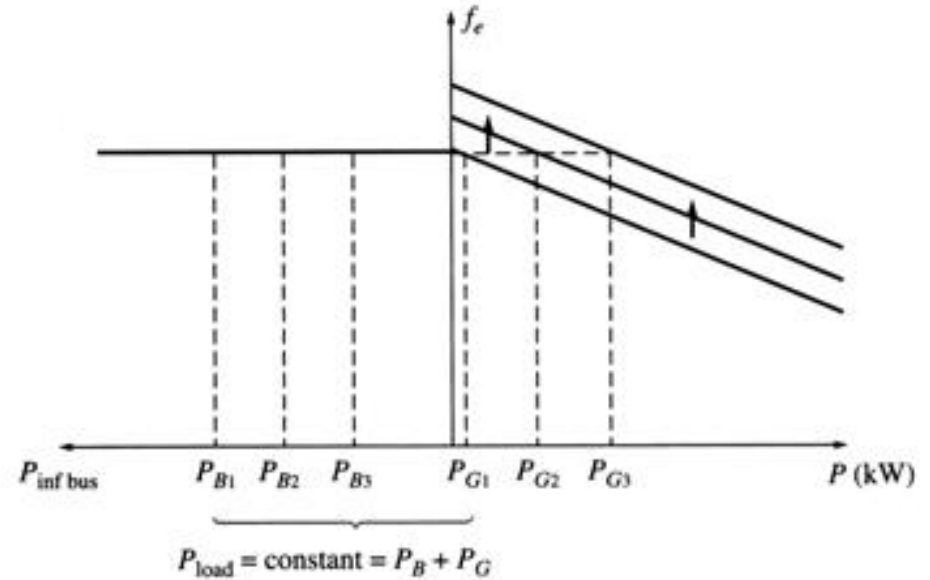

- Note an increase in power (with V_t and E_A staying constant), results in an increase in the power angle δ .

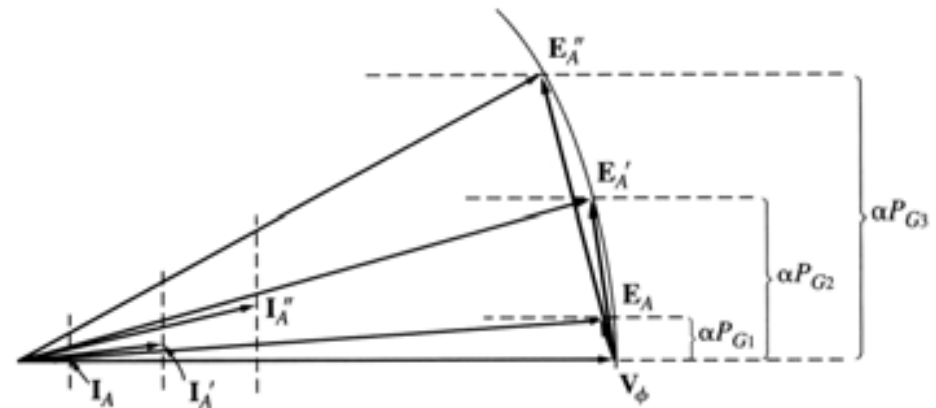

Parallel operation with the utility grid

- By adjusting the field current of the machine, it is possible to make it to make the generator supply or consume reactive power Q .
- Summary: when the generator is operating in parallel with an infinite bus:
 - The frequency and terminal voltage of the generator are controlled by the system to which it is connected.
 - The governor set point of the generator controls the real power supplied by the generator to the system.
 - The generator's field current controls the reactive power supplied by the generator to the system.

Parallel operation of generators of similar size

- Unlike the case of an infinite bus, the slope of the frequency-power curve of G1 is of the same order of magnitude as that of G2.
- The power-frequency diagram right after G2 is connected to the system is shown to the right.
- As indicated previously, in order for G2 to come in as a generator, its frequency should be slightly higher than that of G1.

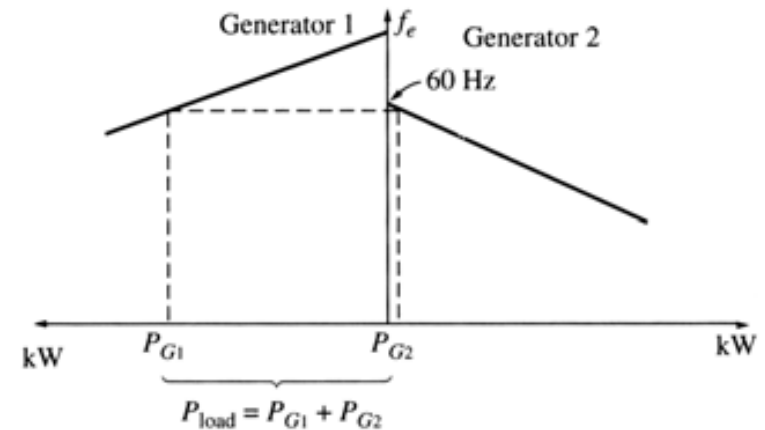
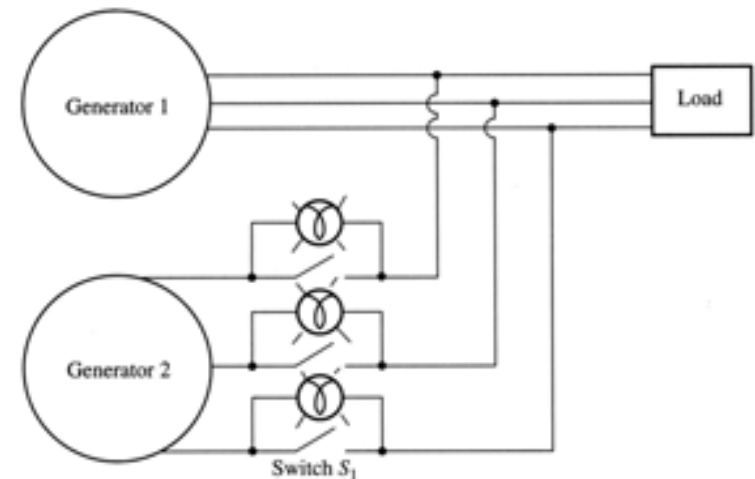

Parallel operation of generators of similar size

- Note that the sum of the real and reactive powers supplied by the two generators must equal the real and reactive powers demanded by the load:

$$P_{tot} = P_{load} = P_{G1} + P_{G2}$$

$$Q_{tot} = Q_{load} = Q_{G1} + Q_{G2}$$

- If the speed of G2 is increased, its power-frequency diagram shifts upwards. This will in turn
 - increase the real power supplied by G2
 - reduce the real power supplied by G1
 - increase the system frequency.
 - To bring the frequency down, the speed of G1 must be reduced.

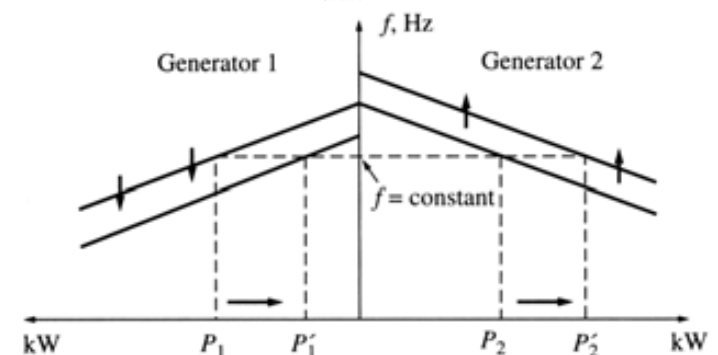
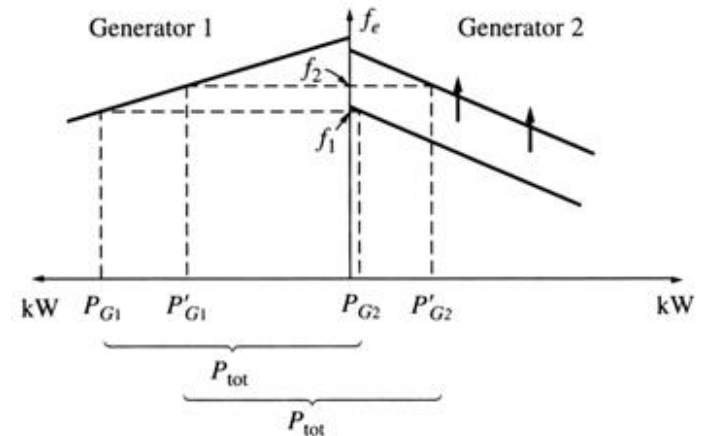
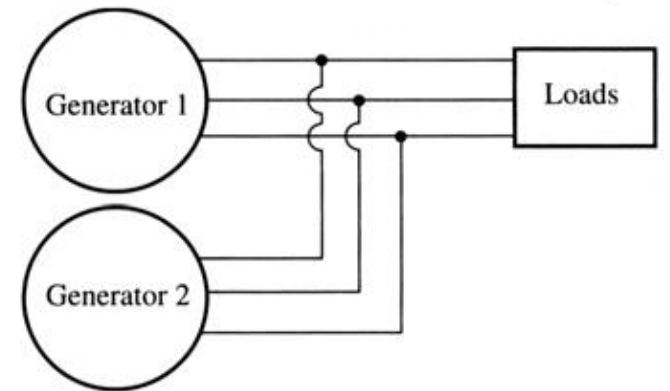

Example

Two generators are set to supply the same load. G1 has a no-load frequency of 61.5 Hz and a slope $sp1$ of 1 MW/Hz. G2 has a no-load frequency of 61.0 Hz and a slope $sp2$ of 1 MW/Hz. The two generators are supplying a real load of 2.5 MW at 0.8 PF lagging.

- System frequency? Ans. 60 Hz
- Power generated by G1 and G2? Ans. 1.5 MW and 1 MW
- An additional load of 1 MW is added, find the system frequency and the generator powers? Ans. 59.5 Hz, 2 MW, and 1.5 MW
- Repeat c) after the no-load frequency of G2 is increased by 0.5 Hz? Ans. 59.75 Hz, 1.75 MW and 1.75 MW.

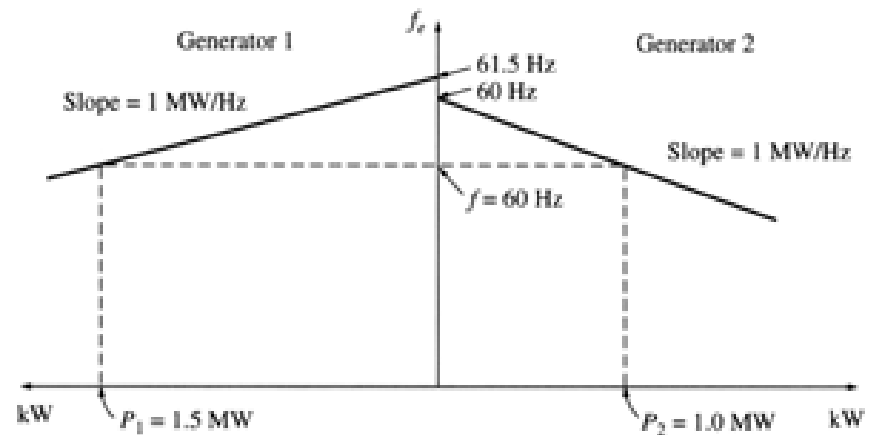

Parallel operation of generators of similar size

- Similarly, an increase in the field current of G2 will result in
 - An increase of the reactive power supplied G2,
 - A reduction of the reactive power supplied G1.
 - An Increase of the system terminal voltage.
 - To bring the voltage down, the field current of G1 must be reduced.

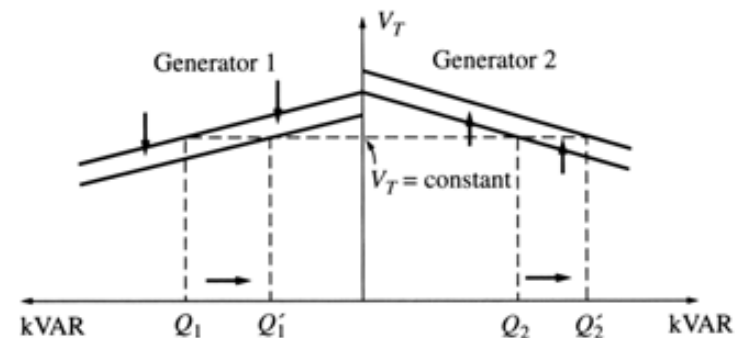
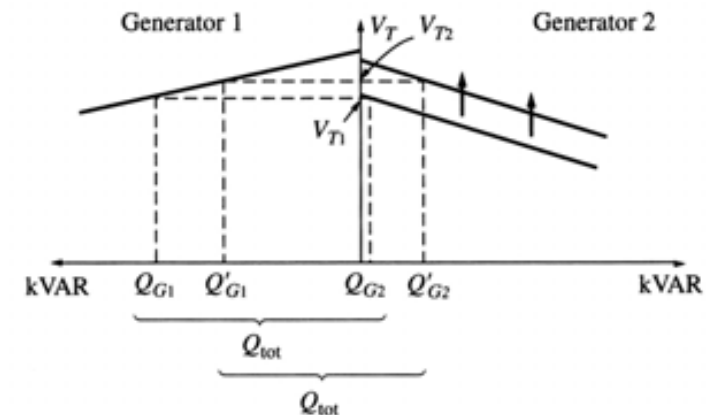
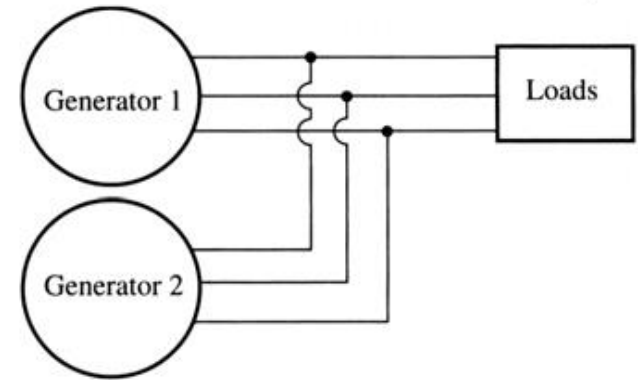

Synchronous Generator Rating

- The purpose of ratings is to protect the machine from damage. Typical ratings of synchronous machines are **voltage, speed, apparent power (kVA), power factor, field current** and **service factor**.
 - The **rated frequency** of a synchronous machine depends on the power system to which it is connected. Once the operation frequency is determined, only one rotational speed is possible for the given number of poles.
 - For a given design, the **rated voltage** is limited by the flux that is capped by the field current. The rated voltage is also limited by the windings insulation breakdown limit.
 - The maximum acceptable armature current sets the **apparent power** rating for a generator. The power factor of the armature current is irrelevant for heating the armature windings.

Synchronous Generator Real and Reactive Power

$$P = V_t I_a \cos \theta$$

$$Q = V_t I_a \sin \theta$$

$$P = \frac{V_t}{X_d} E_i \sin \delta$$

$$Q = \frac{V_t}{X_d} \{E_i \cos \delta - V_t\}$$

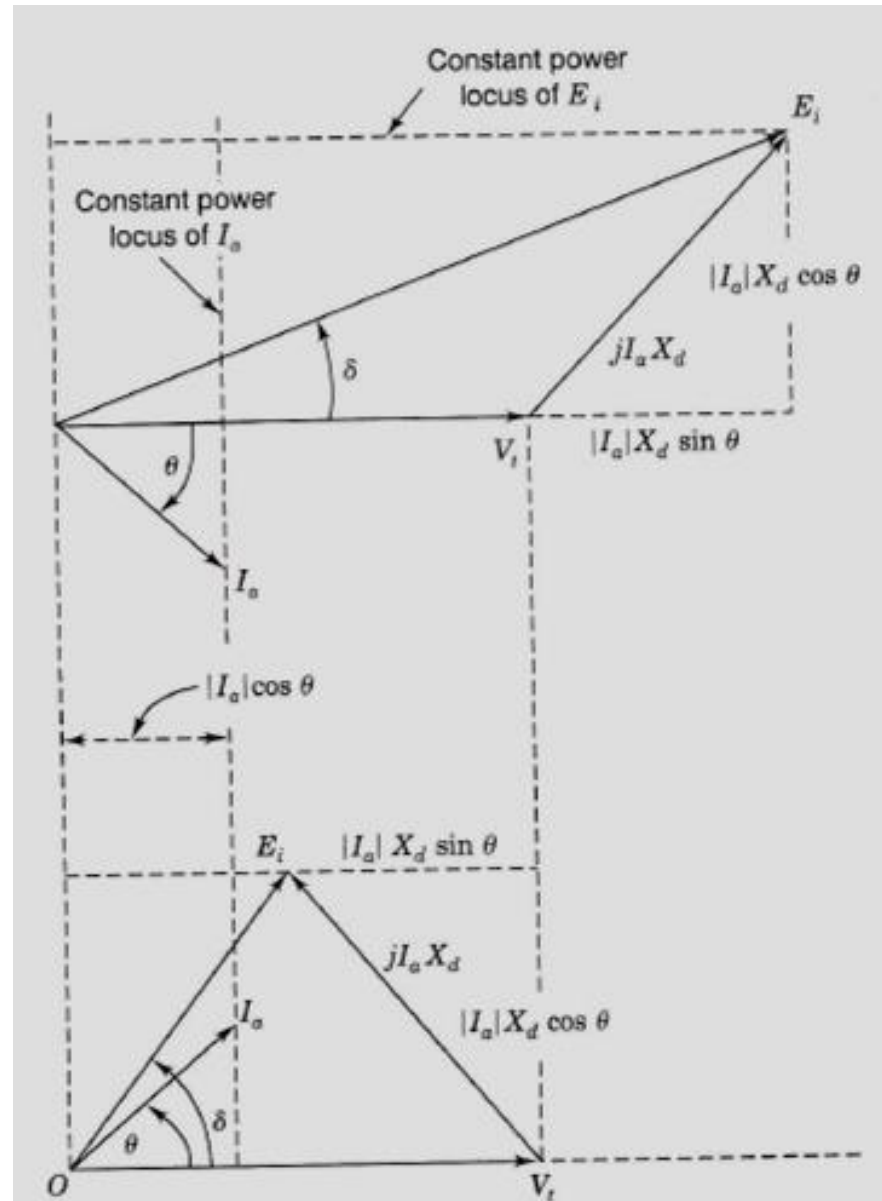

Generator Loading Capability Diagram

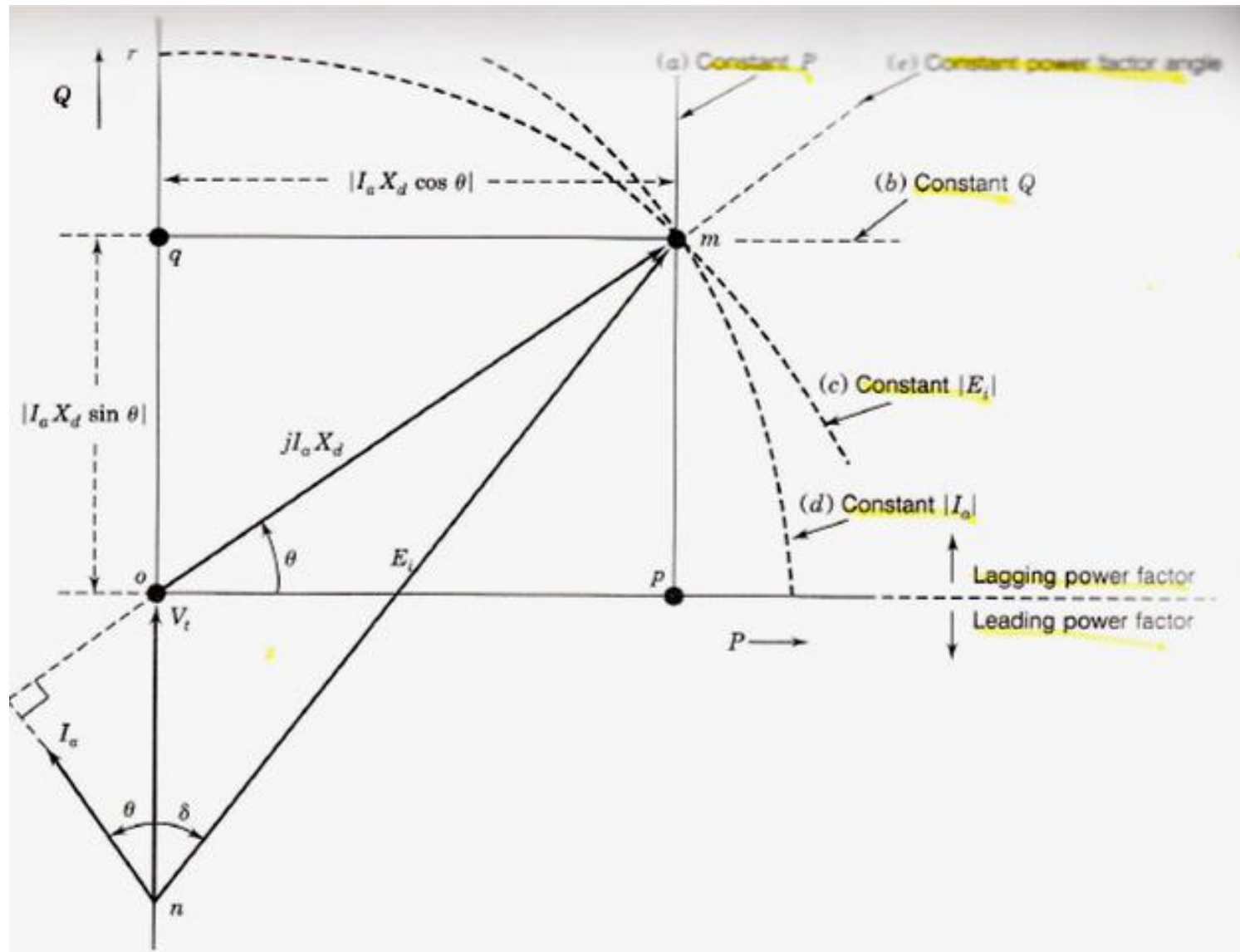

Generator Loading Capability

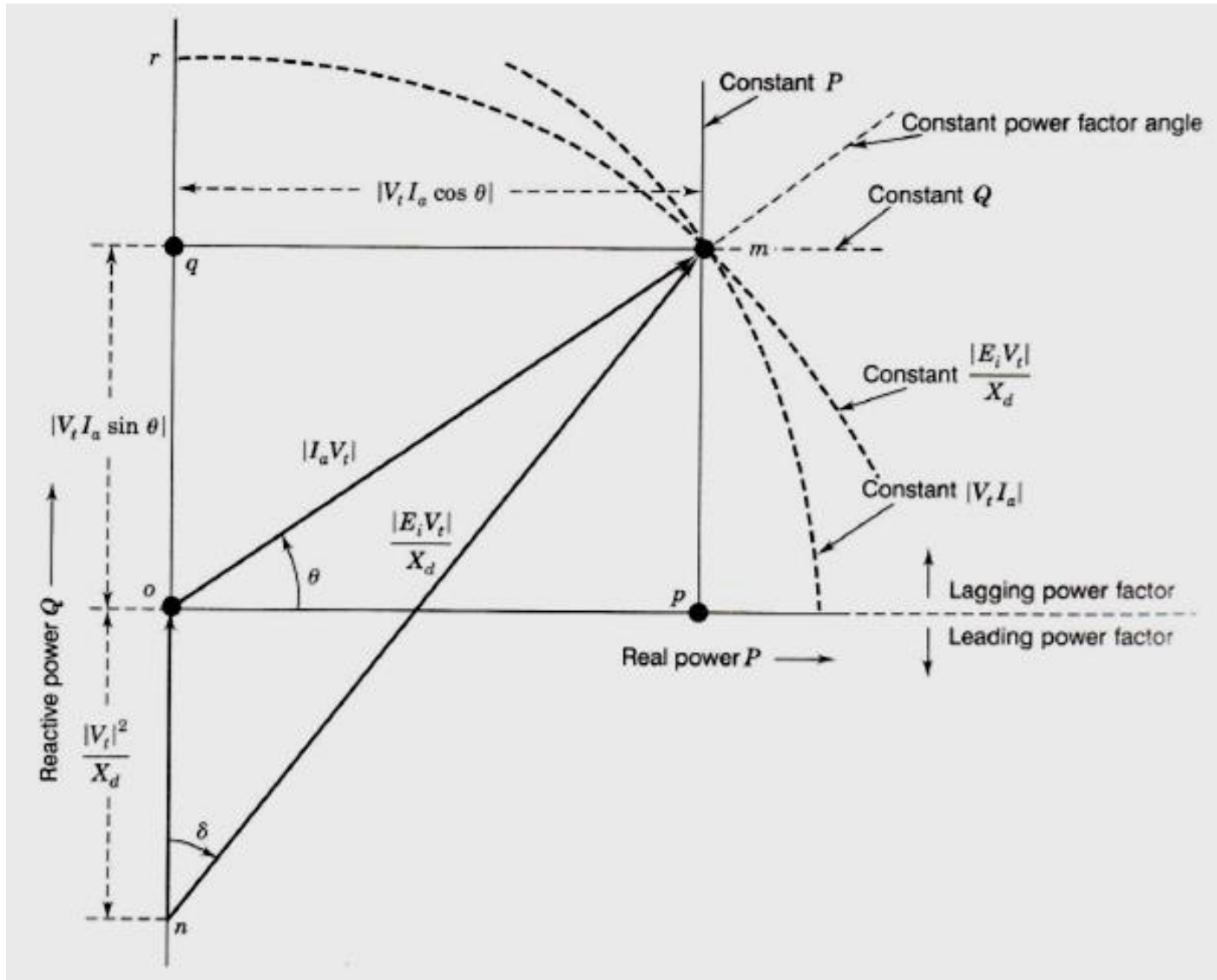

Generator Loading Capability Curve

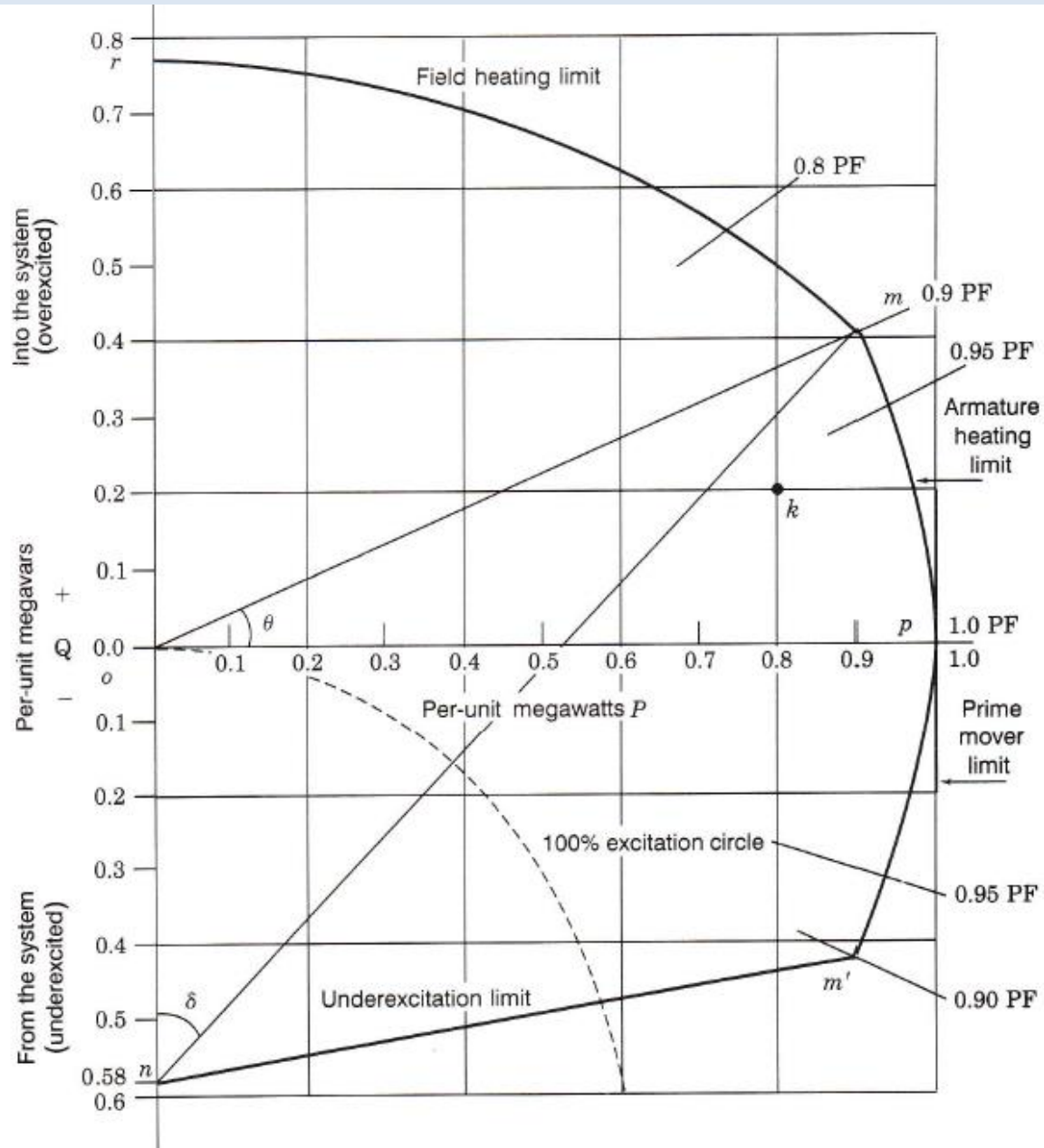

Practice Problems

- Solve problems 6.2 through 6.7.