

EE 340L – Experiment 6: Synchronous Generator - Operation with the Grid

The synchronous machine (see Fig. 1) is mechanically coupled to the Four-Quadrant Dynamometer/Power Supply (see Fig. 2) using a timing belt. This second machine is used as a prime mover to provide mechanical power to the first electric generator. Figure 3 shows the synchronizing module that will assist with the synchronization process.

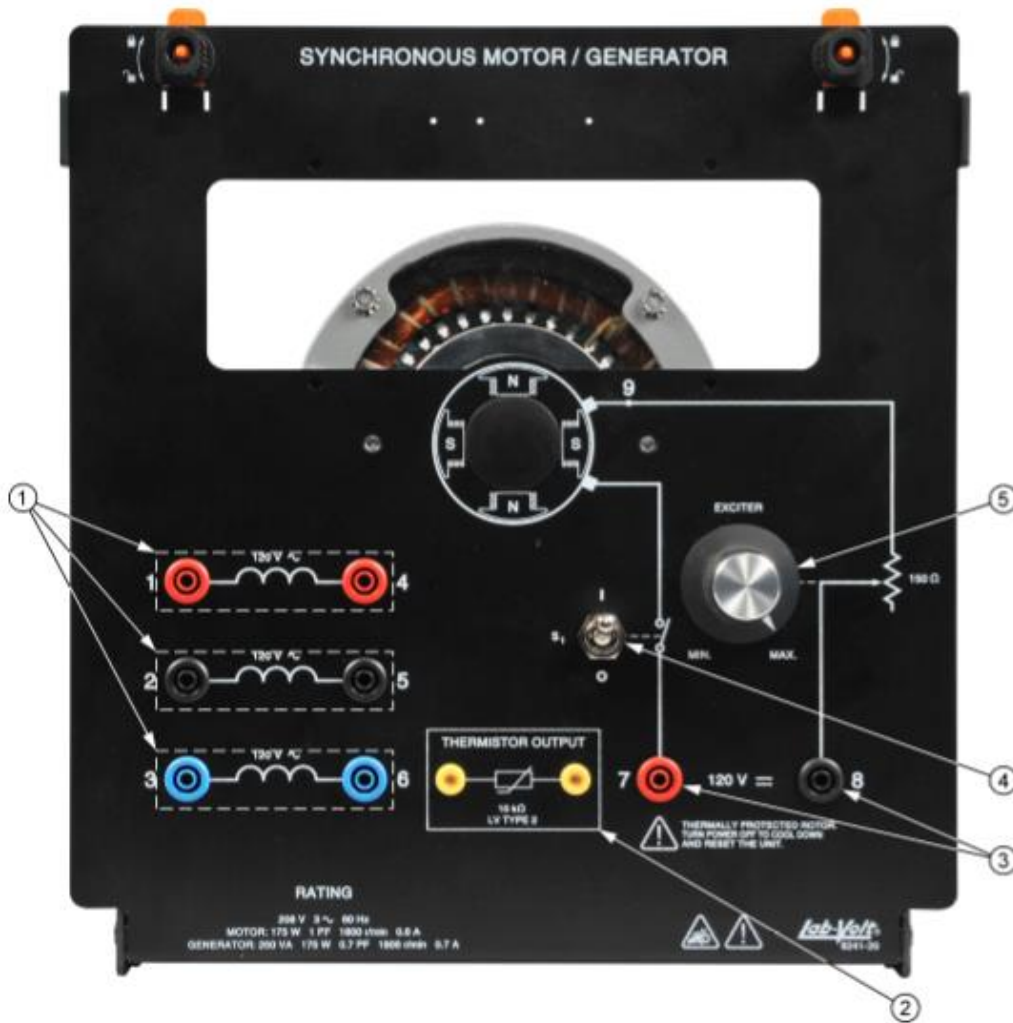

Fig. 1: Synchronous Machine

1. Stator winding terminals:
2. Thermistor Output.
3. Exciter input terminals:
4. Exciter switch.
5. Exciter knob:

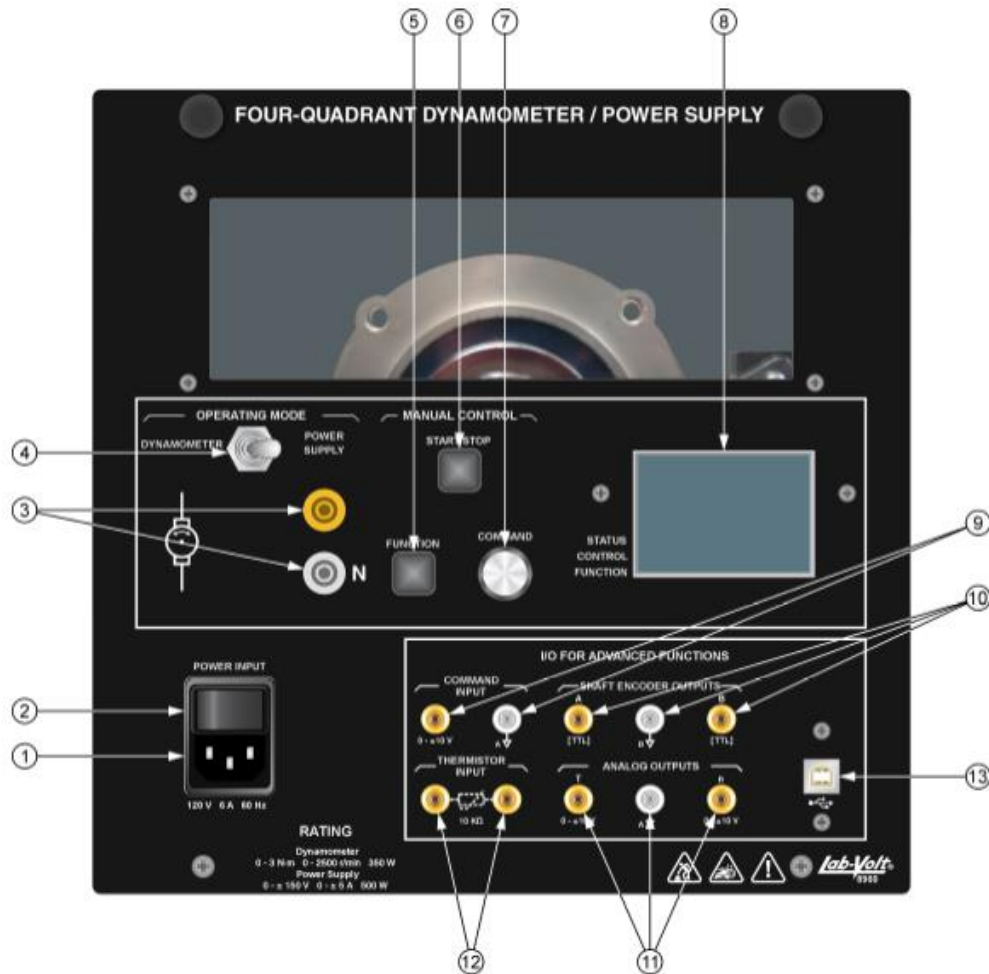

Fig. 2: Four-Quadrant Dynamometer/Power Supply

1. Power Input:
2. Main power switch:
3. Power Supply terminals
4. Operating Mode switch:
5. Function push-button:
6. Start/Stop push-button:
7. Command knob:
8. Liquid crystal display (LCD):
9. Command Input:
10. Shaft Encoder Outputs:
11. Analog Outputs
12. Thermistor Input:
13. USB port connector:

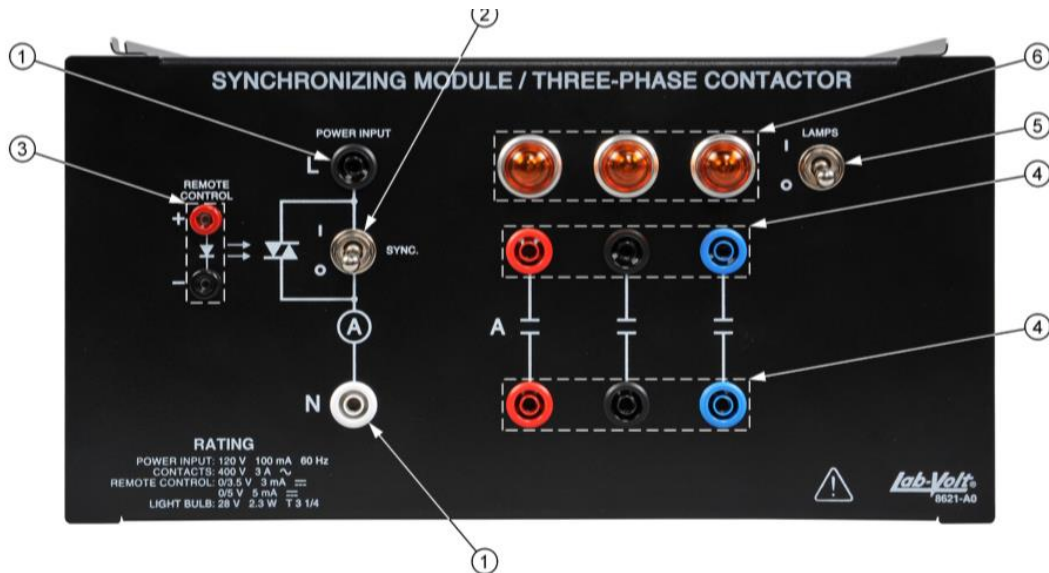

Figure 3: Synchronizing Module.

1. Input Power Terminals (to energize coil of the 3-phase Contactor)
2. Syn. Switch (to energize or de-energize coil of contactor A)
3. Remote control (another alternative to energize or de-energize coil of contactor)
4. Contact terminals (of the two power sources to be synchronized)
5. Lamps switch (toggle switch must be set to I (on) for the indicator lamps to be operational).
6. Synchronizing lamps (indicate the relative level of the voltage across the three corresponding contact terminals. These are connected in parallel with the circuit breaker contacts).

1) Synchronizing the Generator with the Grid.

Before synchronizing a three-phase synchronous generator to an ac power network, it is important to ensure that the following synchronization conditions are met:

- The phase sequence of the synchronous generator must be the same as that of the ac power network.
- The synchronous generator output frequency must be equal to the ac power network frequency.
- The synchronous generator voltage must be equal to the ac power network voltage
- The synchronous generator voltage must be in phase with the ac power network voltage.

Connecting a synchronous generator to the ac power network when the above synchronization conditions are not met produces severe electrical and mechanical stress on the generator and can cause serious damage to it.

Procedure:

- a) Connect the equipment as shown in Figure 4 below. This circuit represents a synchronous generator connected to an ac power network through a circuit breaker (three-phase contactor).

- b) Make sure that the main power switch on the Four-Quadrant Dynamometer/ Power Supply is set to the O (off) position, then connect its Power Input to an ac power outlet. Connect the Power Input of the Data Acquisition and Control Interface to a 24 V ac power supply. Turn the 24 V ac power supply on.
- c) On the Synchronizing Module/Three-Phase Contactor, make sure that **the Lamps switch is set to the (I) position**. This ensures that the synchronizing lamps on the module are operational. Also **make sure that the Sync. switch is set to the open (O) position**. This ensures that the synchronous generator is not connected to the ac power network.
- d) Turn on the Four-Quadrant Dynamometer/Power Supply, select dynamometer operation, then under Function select CW rotation, start the prime mover, then increase the speed parameter of the prime mover until it reaches 1790 rpm.
- e) Turn On the 3-phase Power Supply slowly increase the DC voltage across the generator field winding until the phase voltage of the generator (E2) is nearly equal to that of the power supply (E1).
- f) On the Synchronizing Module/Three-Phase Contactor, observe the synchronizing lamps: If they are all flashing simultaneously in synchronism, then we have the correct phase sequence. If not, this indicates that two of the 3 phases are crossed. In this latter case, shut off the power supply, cross two of the phase of the power supply, and start over.
- g) In LVDAC-EMS, open the Oscilloscope, then make the appropriate settings in order to observe the waveforms of the ac power network voltage (E1) and the synchronous generator voltage (E2). Select the ac power network voltage (input E1) as the trigger source of the Oscilloscope. Take a snapshot and describe briefly what you observed (home assignment).
- h) In the Four-Quadrant Dynamometer/Power Supply window, increase the Speed parameter of the prime mover slowly while watching the flashing rate of the lamps until the generator speed reaches 1800 rpm. Then adjust the generator field current until $E1 \approx E2$. Make further necessary adjustments till the lamps become all dark. Observe the waveforms of these voltages on the Oscilloscope, and when these two voltages are equal in amplitude and in phase (that is when the lamps go 100% dark) take a snapshot, then **it is time to set the Sync. switch on the Synchronizing Module/Three-Phase Contactor to the closed (I) position to synchronize the generator to the network**. Then note the active and reactive power supplied by phase 1 of the generator.

P1 = W

Q1 = VAR

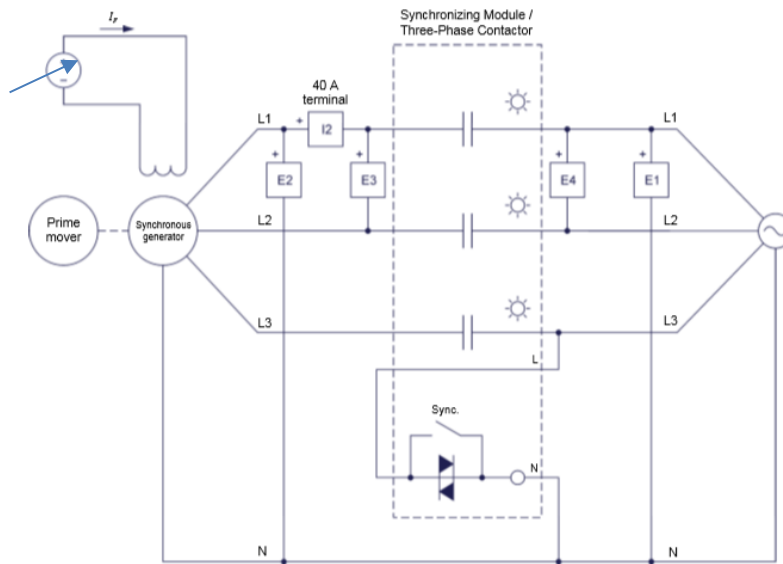

Fig. 4: Generator-power system synchronization.

2) Generator operation after synchronization to the ac power network

Once synchronized with the power network, the generator terminal voltage E_2 is locked to the grid voltage E_1 . Hence, changing the field current won't affect the voltage, but instead, it affects the reactive power supplied by the generator. In addition, the generator frequency is locked to the grid frequency of 60 Hz. Hence, its rotor speed is locked to 1800 rpm, i.e., attempting to change the prime mover speed is not possible, instead, it affects the real power supplied by the generator.

a) Real power control

In the Four-Quadrant Dynamometer/Power Supply window, attempt to increase the Speed parameter of the prime mover slowly in small increments and note what happens to the generator real power, reactive power, and frequency. For each real power value below, record the frequency and reactive power.

Gen. per-phase real power (W)	Gen. per-phase Reactive Power (VAR)	Gen. frequency (Hz)
20		
30		
40		
50		
60		
70		

b) Reactive power control

Adjust the Speed parameter of the prime mover backwards so that the generator active power is as close as possible to 0 W. Then on the Synchronous Motor/Generator, vary the setting of the Exciter knob in slow increments, and record the observed reactive power, real power, and voltage phase voltage E2. Fill in the table below.

Gen. per-phase real power (W)	Gen. per-phase Reactive Power (VAR)	Phase voltage (V)
	-30	
	-20	
	-10	
	0	
	10	
	20	
	30	

Once finished, set the Sync. switch on the Synchronizing Module/Three-Phase Contactor to the open (0) position to disconnect the generator from the power network, stop the prime mover, then turn off the 3-phase power supply. Close the LVDAC-EMS. Disconnect all leads and return them to their storage location.