

Photovoltaic Systems III

EE 446/646

Stand-alone PV System

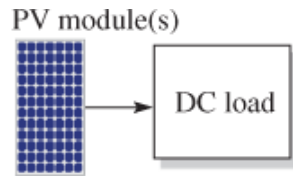

(a) System 1

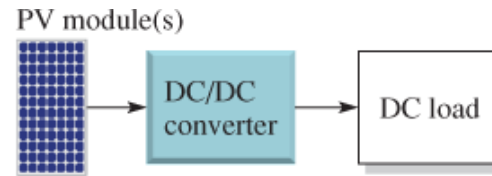

(b) System 2

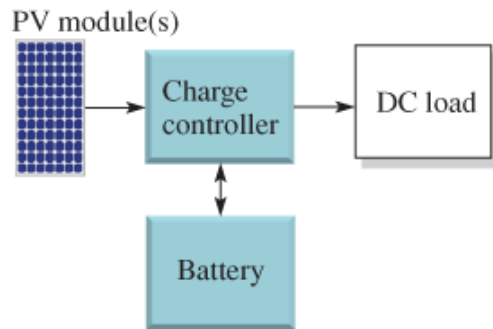

(c) System 3

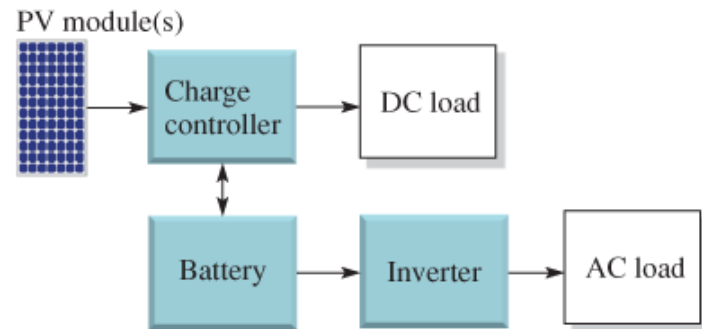

(d) System 4

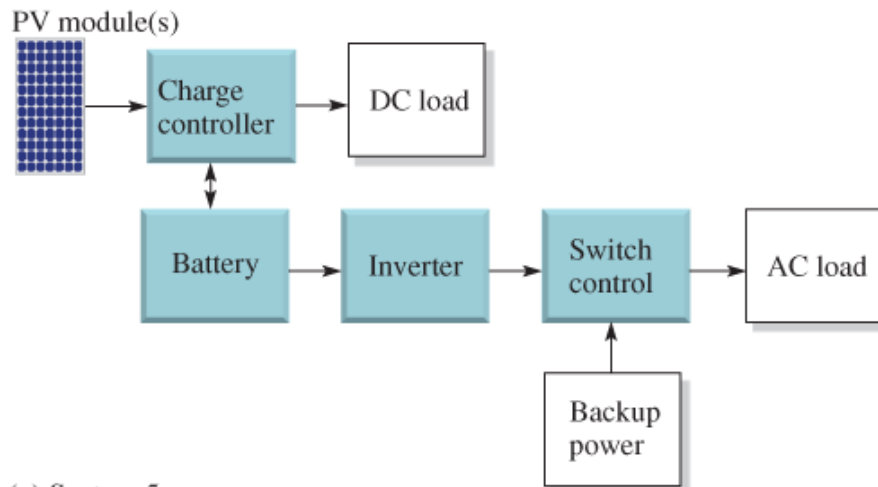

(e) System 5

Stand-alone PV Systems

- When the grid isn't nearby, electricity becomes much more valuable and the extra cost and complexity of a self-sufficient, stand-alone power system can provide enormous benefit.
 - Instead of competing with 10-cent utility power, a PV– battery system competes with 50-cent gasoline or diesel-powered generators.
 - Or it competes with the cost of bringing the grid to the site, which may run many thousands of dollars per mile.
- Off-grid systems must be designed with great care to assure satisfactory performance. Users must be willing to
 - adjust their energy demands as the weather varies,
 - fuel and maintain a noisy generator,
 - take responsibility for the safe operation of the system.

Sizing a stand-alone PV system

- Power needed by the load, as well as energy required over time by that load, is important for system sizing.
 - Various iterations will follow in which trade-offs are made between more expensive, but more efficient, appliances and devices in exchange for fewer PVs and batteries.
 - Lifestyle adjustments need to be considered in which some loads are treated as essentials that must be provided for, and others are luxuries to be used only when conditions allow.
 - A key decision involves whether to use all dc loads to avoid the inefficiencies associated with inverters, or whether the convenience of an all ac system is worth the extra cost,
 - Another important decision is whether to include a generator back-up system and, if so, what fraction of the load it will have to supply.

Power requirements of typical loads

Kitchen Appliances

	<i>Power</i>
Refrigerator: ac EnergyStar, 14 cu. ft	300 W, 1080 Wh/day
Refrigerator: ac EnergyStar, 19 cu. ft	300 W, 1140 Wh/day
Refrigerator: ac EnergyStar, 22 cu. ft	300 W, 1250 Wh/day
Refrigerator: dc Sun Frost, 12 cu. ft	58 W, 560 Wh/day
Freezer: ac 7.5 cu. ft	300 W, 540 Wh/day
Freezer: dc Sun Frost, 10 cu. ft	88 W, 880 Wh/day
Electric range (small burner)	1250 W
Electric range (large burner)	2100 W
Dishwasher: cool dry	700 W
Dishwasher: hot dry	1450 W
Microwave oven	750–1100 W
Coffeemaker (brewing)	1200 W
Coffeemaker (warming)	600 W
Toaster	800–1400 W

General Household

Clothes washer: vertical axis	500 W
Clothes washer: horizontal axis	250 W
Dryer (gas)	500 W
Vacuum cleaner	1000–1400 W

Power requirements of typical loads (cont.)

Furnace fan: 1/4 hp	600 W
Furnace fan: 1/3 hp	700 W
Furnace fan: 1/2 hp	875 W
Ceiling fan	65–175 W
Whole house fan	240–750 W
Air conditioner: window, 10,000 Btu	1200 W
Heater (portable)	1200–1875 W
Compact fluorescent lamp (100-W equivalent)	30 W
Compact fluorescent lamp (60-W equivalent)	16 W
Electric blanket, single/double	60/100 W
Clothes iron	1000–1800 W
Electric clock	4 W

Consumer Electronics

TV: >39-in. (active/standby)	142/3.5 W
TV: 25 to 27-in. color (active/standby)	90/4.9 W
TV: 19 to 20-in. color (active/standby)	68/5.1 W
Analog cable box (active/standby)	12/11 W
Satellite receiver (active/standby)	17/16 W
VCR (active/standby)	17/5.9 W
Component stereo (active/standby)	44/3 W
Compact stereo (active/standby)	22/9.8 W
Cordless phone	4 W
Clock radio (active/standby)	2.0/1.7 W
Computer, desktop (active/idle/standby)	125/80/2.2 W
Laptop computer	20 W

Power requirements of typical loads (cont.)

Ink-jet printer	35 W
Dot-matrix printer	200 W
Laser printer	900 W
<i>Shop</i>	
Circular saw, 7 1/4"	900 W
Table saw, 10-in.	1800 W
Hand drill, 1/4"	250 W
<i>Water Pumping</i>	
Centrifugal pump: 36 Vdc, 50-ft @ 10 gpm	450 W
Submersible pump: 24 Vdc, 100-ft @ 1.6 gpm	100 W
Submersible pump: 48 Vdc, 300-ft @ 1.5 gpm	180 W
DC pump (house pressure system), typical use 1–2 h/day	60 W

Source: Rosen and Meier (2000) and others.

Example 1: A Modest Household Demand

- Estimate the daily energy demand for a cabin with all ac appliances, consisting of a 19-cu. ft refrigerator, six 30-W compact fluorescents (CFLs) used 5 h/day, a 19-in. TV turned on 3 h/day and connected to a satellite, a cordless phone, a 1000-W microwave used 6 min/day, and a 100-ft deep well that supplies 120 gallons/day.

• *Answer:*

Appliance	Power (W)	Hours	Watt-hours/day	Percentage
Refrigerator, 19 cu. ft	300		1140	37%
Lights (6 @ 30 W)	180	5	900	29%
TV, 19-in., active mode	68	3	204	7%
TV, 19-in., standby mode	5.1	21	107	3%
Satellite, active mode	17	3	51	2%
Satellite, standby mode	16	21	336	11%
Cordless phone	4	24	96	3%
Microwave	1000	0.1	100	3%
Washing machine	250	0.2	50	2%
Well pump, 100 ft, 1.6 gpm	100	1.25	125	4%
Total	1,919		3109	100%

Accounting for inverter losses

- the load calculation needs to be modified to account for losses in the dc-to-ac inverter.
 - The inverter's efficiency is a function of the magnitude of the load it happens to be supplying at that particular instant.
 - Most inverters now operate at around 90-95% efficiency over most of their range.

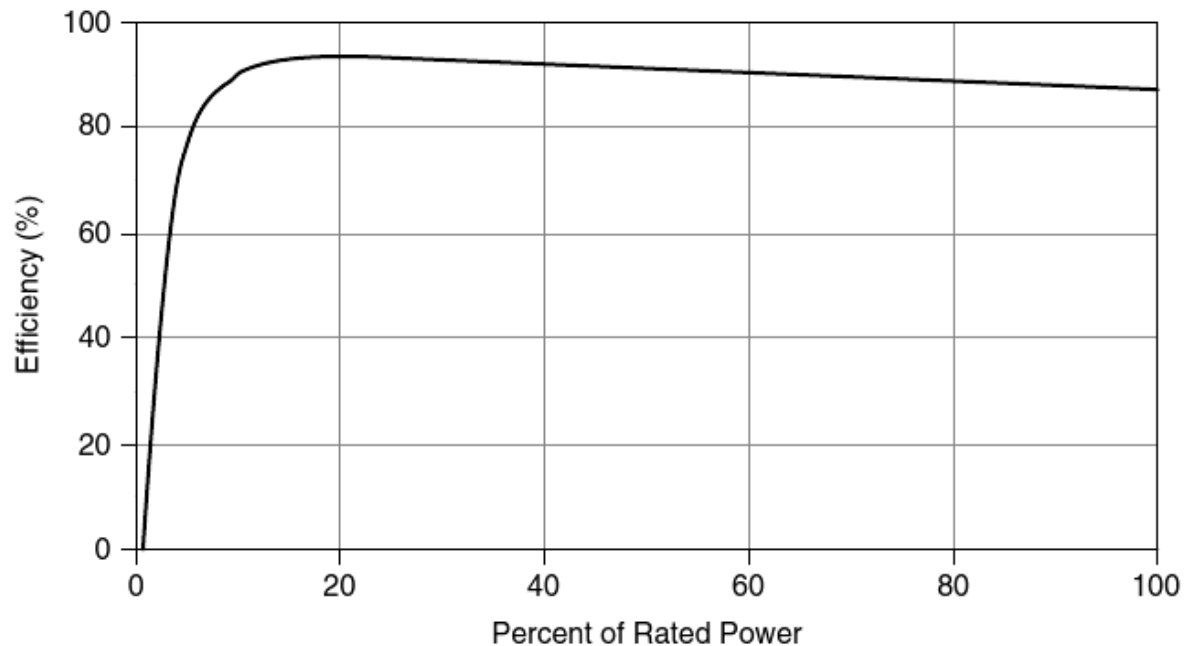

Inverter rating

- Inverters are specified by their
 - dc input voltage
 - ac output voltage,
 - continuous power handling capability,
 - amount of surge power they can supply for brief periods of time.
- The inverter's dc input voltage, which is the same as the voltage of the battery bank and the PV array, is usually 12 V, 24 V, or 48 V.
 - Higher voltages need less current, making it easier to minimize wire losses.
- See guideline used to pick the system voltage (while keeping the current below 100 A) in next slide.

Inverter rated power

TABLE 9.11 Suggested System Voltages Based on Limiting Current to 100 A

Maximum ac Power	System dc Voltage
<1200 W	12 V
1200–2400 W	24 V
2400–4800 W	48 V

- The maximum ac power that the inverter needs to deliver is estimated by adding the power demand of all of the loads that will ever be anticipated to be operating simultaneously.
 - For the house in example 1, the total power is 1,919 W. Hence the choice for the system dc voltage is 24 V.

Steady-state and surge power requirements of example loads

Load	Steady State (watts)	Surge (watts)
Refrigerator (ac)	300	1500
Refrigerator (dc)	58	700
Dishwasher	700	1400
Jet pump (1/3 hp) (ac)	750	1400
Submersible pump (ac)	1000	6000
Clothes washer (vertical axis)	650	1150
Clothes washer (horizontal axis)	250	750
Dryer (gas)	500	1800
Furnace fan 1/4 hp	600	1000
Furnace fan 1/3 hp	700	1400
Furnace fan 1/2 hp	875	2350
Air conditioner, window 10 kBtu	1200	1500
Worm drive 7 1/4" saw	1800	3000
Table saw, 10"	1800	4500

Source: Real Goods (2002).

Sample of Inverter/charger electrical specifications

MS SERIES INVERTER/CHARGER SPECIFICATIONS

Suitable for Example 1

	MS2000/12 MS2012(-15/-20B)	MS2812	MS2024	MS4024	MS4048 MS4048-20B
INVERTER SPECIFICATIONS					
Input battery voltage range	9 - 16.8 VDC	9 - 16.8 VDC	18 - 33.6 VDC	18 - 33.6 VDC	36 - 67.6 VDC
AC output voltage accuracy	120 VAC ± 5%	120 VAC ± 5%	120 VAC ± 5%	120 VAC ± 5%	120 VAC ± 5%
Output frequency and accuracy	60 Hz ± 0.1 Hz	60 Hz ± 0.1 Hz	60 Hz ± 0.1 Hz	60 Hz ± 0.1 Hz	60 Hz ± 0.1 Hz
Total Harmonic Distortion (THD)	< 5%	< 5%	< 5%	< 5%	< 5%
1 msec surge current (amps AC)	50	70	75	120	120
100 msec surge current (amps AC)	33	40	37	82	72
5 sec surge power (real watts)	3300	3900	2850	5800	8500
30 sec surge power (real watts)	3100	3800	2750	5400	5750
5 min surge power (real watts)	2800	3200	2700	4900	5250
30 min surge power (real watts)	2200	3000	2200	4500	4750
Maximum continuous input current	267 ADC	373 ADC	133 ADC	267 ADC	133 ADC
Inverter efficiency (peak)	90.6%	90%	86%	93.7%	94%
AC Relay Transfer time (minimum)	16 msec	16 msec	16 msec	16 msec	16 msec
Power Consumption - searching	<8 watts	<8 watts	<8 watts	<8 watts	<8 watts
Power Consumption - inverting (no load)	25 watts	30 watts	25 watts	25 watts	25 watts
Output Waveform	Pure Sine Wave	Pure Sine Wave	Pure Sine Wave	Pure Sine Wave	Pure Sine Wave
CHARGER SPECIFICATIONS					
Continuous output at 25° C	100 ADC	125 ADC	60 ADC	105 ADC	60 ADC
Charger efficiency	85%	85%	85%	85%	85%
Power factor	> .95	> .95	> .95	> .95	> .95
Input current for continuous rated output	15 AAC	18 AAC	7.9 AAC	29 AAC	30 AAC
GENERAL FEATURES AND CAPABILITIES					

Batteries

- Conventional lead-acid batteries vs. Lithium batteries. For comparison in terms of cost, life-cycle, efficiency, etc... see <https://www.wholesalesolar.com/deep-cycle-solar-batteries>



<https://www.wholesalesolar.com/cms/discover-battery-aes-1.0kwh-24vdc-battery-specs-1307109147.9979965.pdf>



<https://www.wholesalesolar.com/cms/crown-6crv390-agm-battery-manual-3306454493.pdf>

Impact of depth of discharge on number of cycles for lead-acid batteries

- The deeper the depth of discharge, the shorter is the battery life.
- Relation between state of charge and depth of discharge:

$$\text{SOC (\%)} = 100 - \text{DOD (\%)}$$

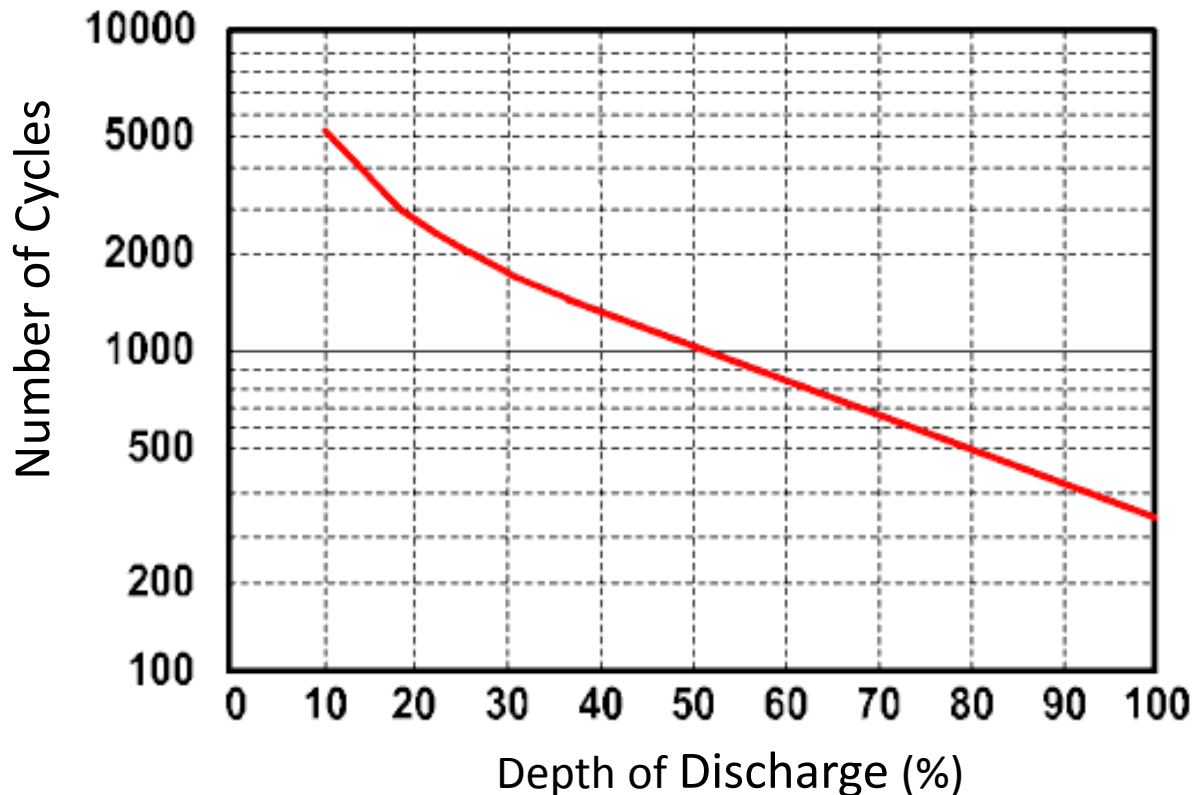

allowable depth of discharge of a lead-acid battery in cold climates

- The battery is more vulnerable to freezing in its discharged state since the anti-freeze action of the sulfuric acid is diminished when there is less of it present.

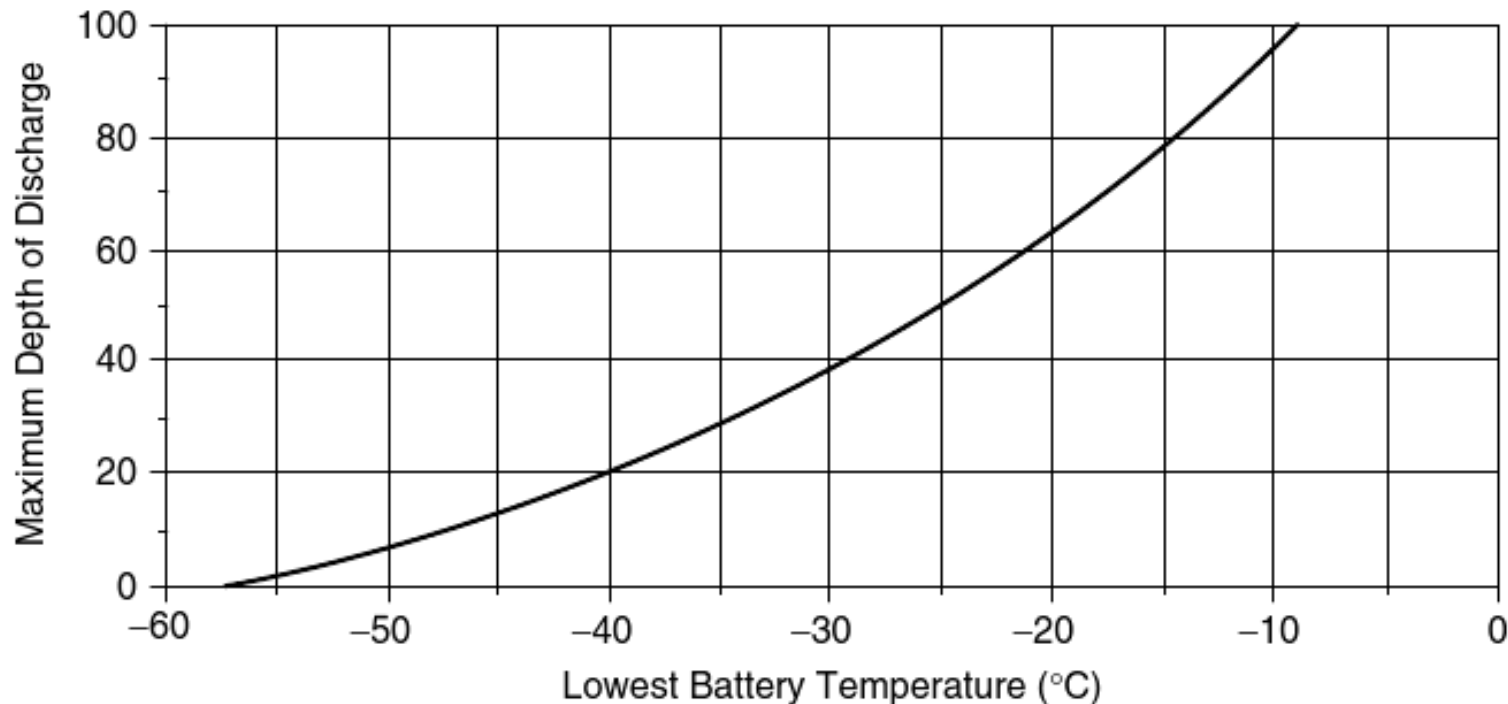

Battery storage capacity

- Energy storage in a battery is typically given in units of amp-hours (Ah) at some specified discharge rate.
- *Example:* a 12 V battery that is rated at 200 Ah at 10-hour rate, is expected to deliver 20 A for 10 hours. It is said that it is discharging at rate of C/10 (i.e., $200\text{Ah}/10\text{h} = 20\text{ A}$)
 - At C/4, the battery will have a capacity lower than 200 Ah
 - At C/20, the battery will have a capacity higher than 200 Ah
 - Battery Ah capacity depends on the rate of discharge!
- It is not easy to specify how much energy the battery delivered during its discharge: Energy is volts x amps x hours, but the voltage varies throughout the discharge period.

Battery Capacity at different discharge rates

- Deep-cycle batteries intended for photovoltaic systems are often specified at different discharge rates (with C/20 being the most common rating).

Specification

Nominal Voltage	12 volts			
Nominal Capacity	77° F (25° C)			
20-hr. (12.50A)	230 Ah			
10-hr. (23.25A)	232.5 Ah			
5-hr. (42.50A)	212.5 Ah			
1-hr. (150.00A)	150 Ah			
Approximate Weight	154 lbs (70 kgs)			
Internal Resistance (approx.)	4 mOHMS			
Shelf Life (% of normal capacity at 77° F (25° C))				
	3 Months	6 Months	12 Months	
	91%	82%	64%	
Temperature Dependency of Capacity	(20 hour rate)			
	104° F	77° F	32° F	5° F
	102%	100%	85%	65%

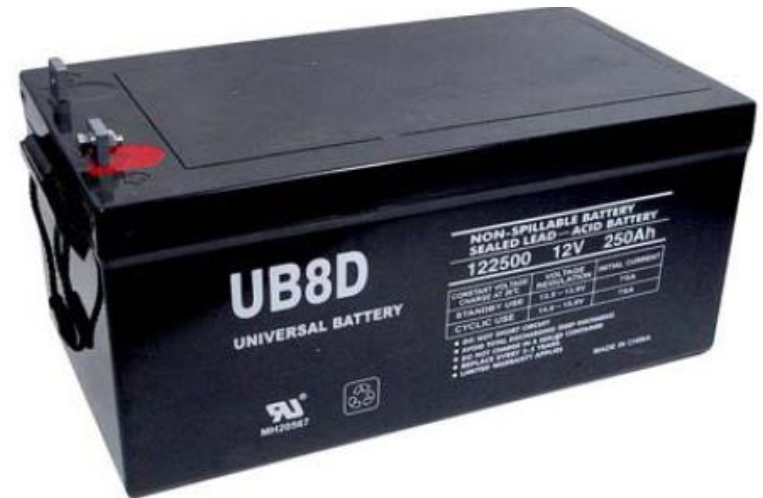

Charge Method (Constant Voltage)

Cycle Use (Repeating Use)

Initial Current	87.5 A or smaller
Control Voltage	14.5 - 14.9 V

Float Use

Control Voltage	13.6 - 13.8 V
-----------------	---------------

Battery capacity

- Note the specified battery capacity (Ah) below applies only for a specific discharge rate (i.e., 11.6 A for 20 hours).
- If the battery is discharged at 75 A, it will last for only 2 hours, (i.e., its capacity drops from 232 Ah down to 152 Ah).



US BATTERY
US 2200 X6
DEEP CYCLE
DIAMOND PLATE TECHNOLOGY

SPECIFICATIONS:
Length: 10-1/4" (260mm)
Width: 7-1/8" (181mm)
Height: 11-1/4" (286mm)

AMP HOURS & CAPACITY:
Amp Hours (20 hr. rate): **232**
M.C.A. @ 32° F: --- min @ 56amps
Minutes @ 75 Amps: **122** min.
Minutes @ 25 Amps: **474** min.

Capacity dependence on temperature

- Battery capacity depends not only on discharge rate, but also on temperature.
 - In cold temperatures, the battery capacity is reduced.
 - In warm temperatures, the battery capacity is increased.

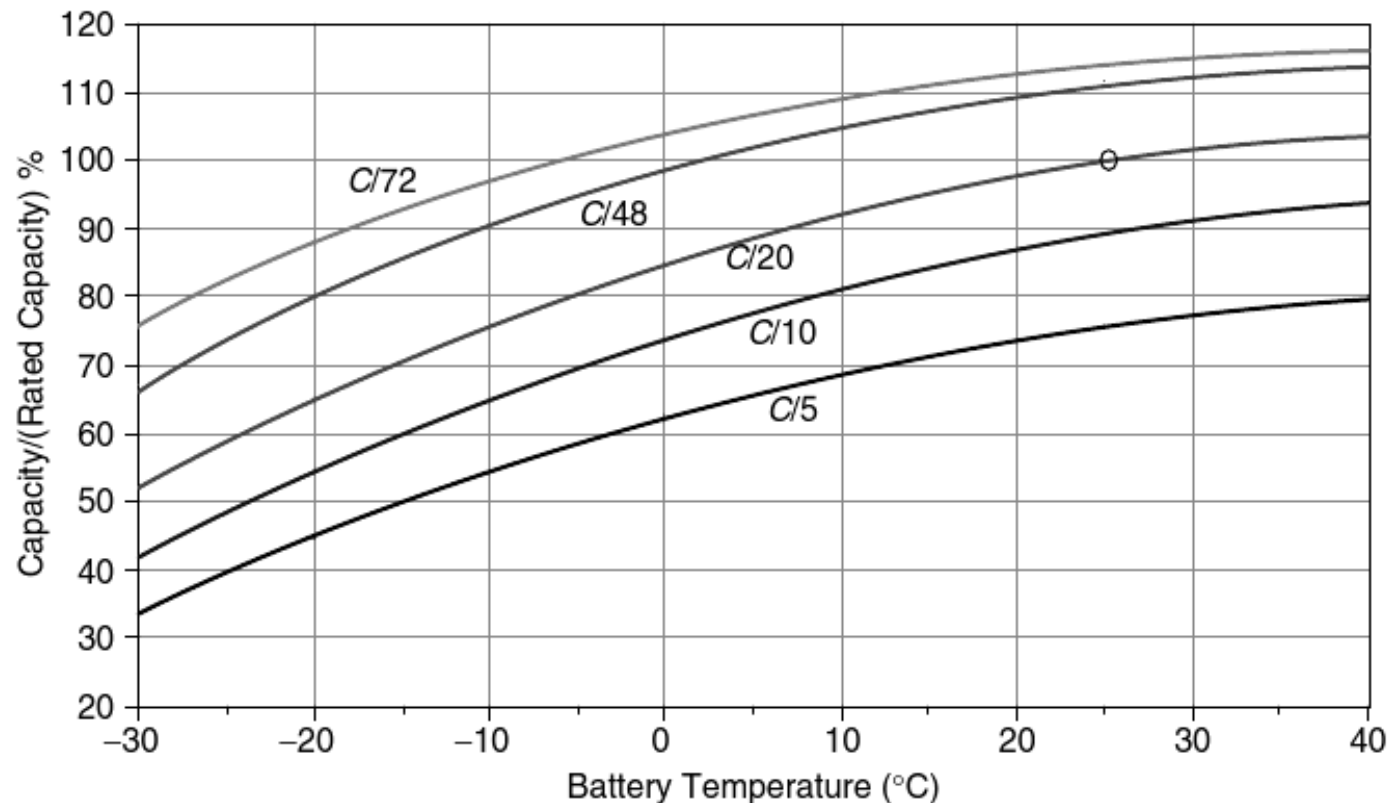

Ratio is based on a rated capacity at C/20 and 25°C

Battery connections

- a) For batteries wired in parallel, amp-hours add up
- b) For batteries in series, voltages add up
- c) For series/parallel combinations, both voltages and amp-hours add up

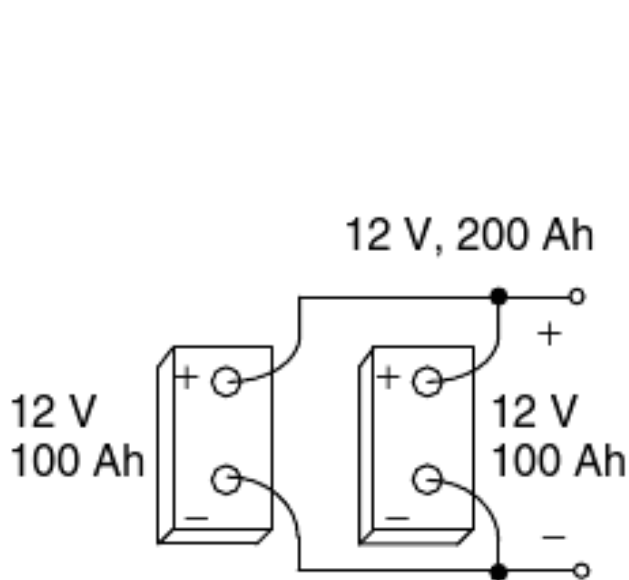

(a) Parallel, Amp-Hrs add

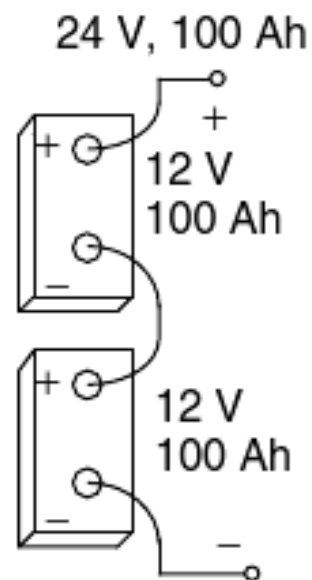

(b) Series, Voltages add

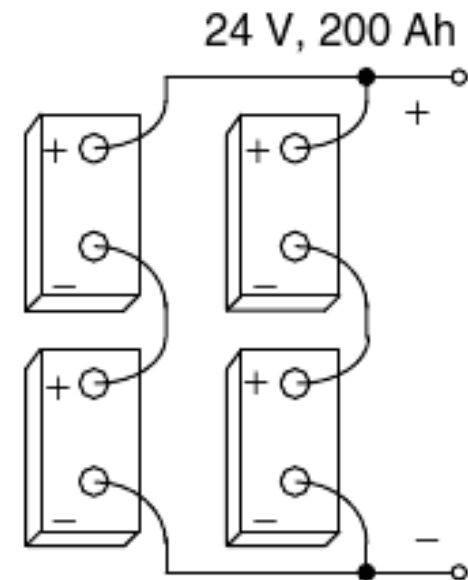

(c) Series/Parallel

Coulomb, voltage and Energy Efficiency

- The round trip energy efficiency of a battery is given by

$$\text{Energy efficiency} = \frac{E_{\text{out}}}{E_{\text{in}}} = \frac{V_D I_D \Delta T_D}{V_C I_C \Delta T_C}$$

$$\text{Energy efficiency} = (\text{Voltage efficiency}) \times (\text{Coulomb efficiency})$$

- where subscripts “D” and “C” are respectively associated with discharging and charging
- **Example A:** a battery is charged for one hour at a voltage and current of 14 V and 10 A. It is then discharged for one hour at a voltage and current of 9 A and 12 V. Its round trip energy efficiency is $(12/14) \times (9 \times 1 / 10 \times 1) = (0.86) \times (0.9) = 0.77$ (or 77%).

Lead-Acid Battery voltage during charging and discharging as a function of SOC

During charging, the voltage rises faster with the rate of charge, as the battery nears 80% SOC.

- This is when electrolysis that removes water from the battery takes place.
- It also creates a potentially dangerous situation since hydrogen gas is so explosive. → Proper ventilation of battery storage systems is important.
- Some lead-acid batteries (VRLA) use pressure-relief valves that allow up to 95% of the gases formed during gassing to recombine with lead .
- Charge controllers are designed to slow the charging rate as the battery approaches its fully charged condition.

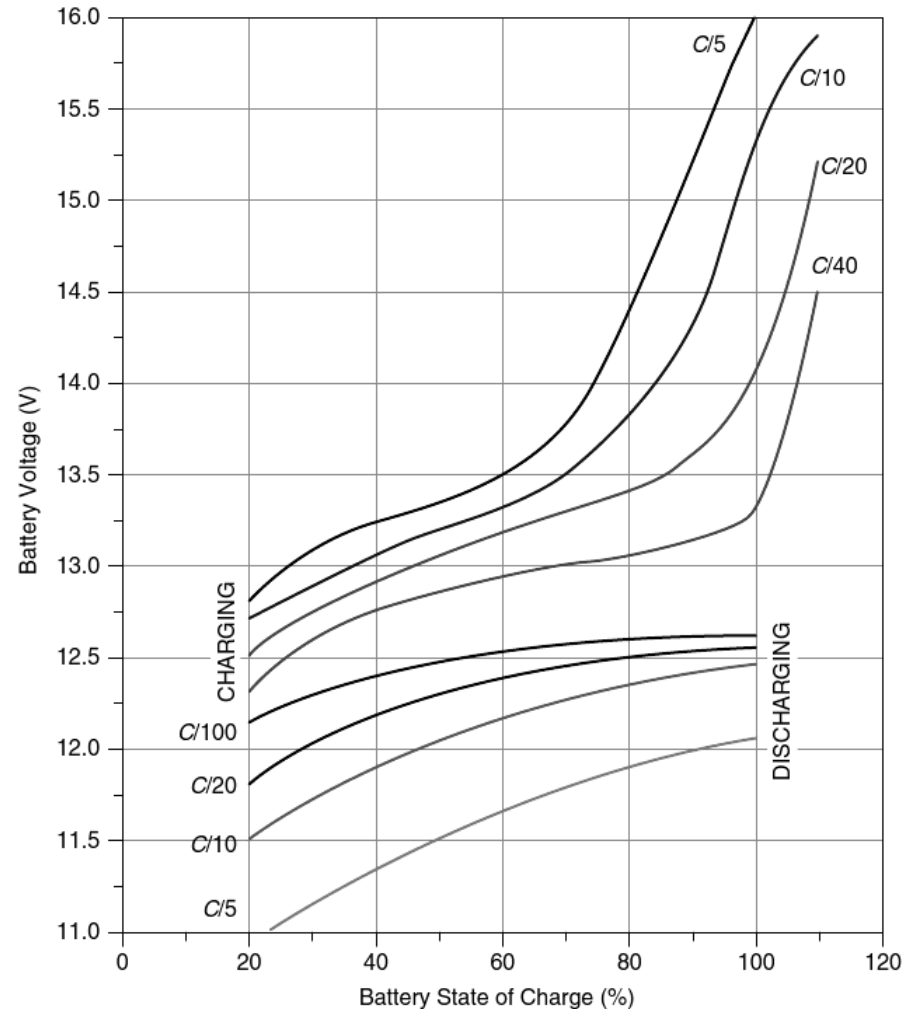

Battery Sizing

- Given the statistical nature of weather, there are no set rules about how best to size battery storage.
- Sizing a storage system to meet the demand 99% of the time can easily cost triple that of one that meets demand only 95% of the time.

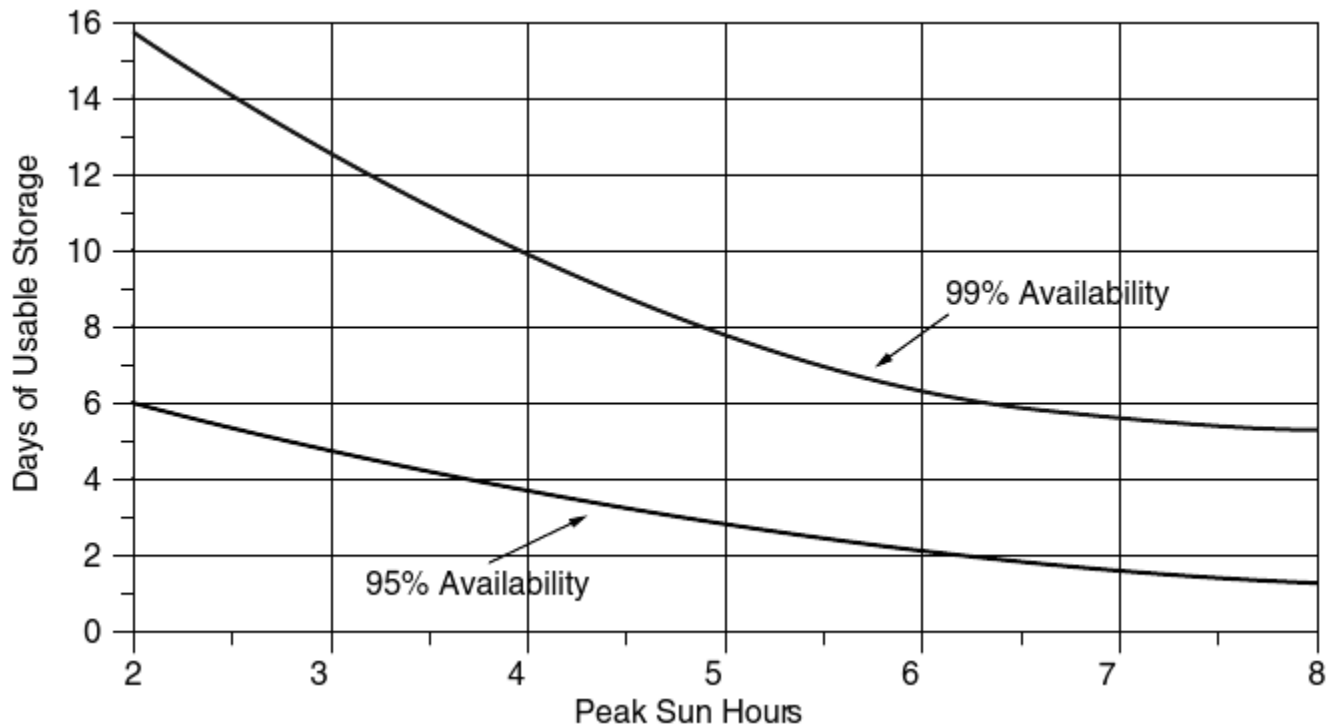

1. Peak sun hours are for the worst month of the year and availability is on an annual basis (Source: SNL, 1995).
2. Days of “usable storage,” means after accounting for impacts associated with maximum allowable battery discharge, Coulomb efficiency, battery temperature, and discharge rate.

Battery Sizing

- The relationship between usable storage and nominal, rated storage (at C/20, 25°C) is given by

$$\text{Nominal (C/20, 25°C) battery capacity} = \frac{\text{Usable battery capacity}}{(\text{MDOD})(T, \text{DR})}$$

- where MDOD is the maximum depth of discharge (default: 0.8 for lead-acid - subject to freeze constraints) and (T, DR) are the temperature and discharge-rate factor (refer to capacity-temp graph).
- Example 1 (cont.)** : Size a battery for 95% availability for a cabin in Salt Lake City, UT, where the AC load demand is 3 kWh/day during the worst winter month. Assume the temperature may reach as low as -10°C, the system voltage is 24 V, and the inverter efficiency is 86%.

Tilt	Jan	Feb	Mar	Apr	May	Jun	July	Aug	Sept	Oct	Nov	Dec	Year
Lat - 15	2.9	4.0	5.0	5.9	6.6	7.2	7.3	7.0	6.3	5.0	3.3	2.5	5.2
Lat	3.2	4.3	5.2	5.8	6.2	6.6	6.7	6.7	6.4	5.4	3.7	2.9	5.3
Lat + 15	3.4	4.4	5.1	5.4	5.5	5.6	5.8	6.1	6.1	5.5	3.9	3.1	5.0

Example 1 (cont.)

- **Answer:**

- *Daily Ah needed: $(3000/0.86)/24 = 145 \text{ Ah}$*
- *Worst insolation: $3.1 \text{ kWh/m}^2/\text{day}$ (Dec.)*
- *Number of storage days needed: 4.6 days*
- *Useable storage: $4.6 \times 145 = 667 \text{ Ah}$*
- *DoD allowed: use the standard value of 80%*
- *DR at specified temperature: 0.97*
- *Nominal battery capacity = $667 / (0.8 \times 0.97) = 860 \text{ Ah @24V}$*
- *If we choose Discover Battery AES 24V, 110 Ah, 8 of these connected in parallel will result in a bank that is rated at 880Ah @ 24 V.*

Array Sizing

- A simple PV sizing procedure is based on the “peak sun hours” approach used for grid-connected systems.
- The PV system should be oriented at $L+15^\circ$ to capture the most sun energy during the worst month of the year.

$$\begin{aligned}\text{Energy (kWh/day)} &= P_{ac} \text{ (kW)} \cdot (\text{PSH}) \\ &= P_{dc,STC} \cdot (\text{derating factor}) \cdot (\text{PSH})\end{aligned}$$

- Following Example B, $\text{PSH} = 3.1$, and assume a derating factor of 80%, then the size of the array with MPPT that is needed is

$$P_{dc,STC} = 3000 / (0.8 \times 3.1) = 1,200 \text{ W}$$

- 4 Canadian Solar CS6K 300 W panels connected in parallel will result in a 1,200 W array, (37 A, 32.4 V)

Operating DC Voltage

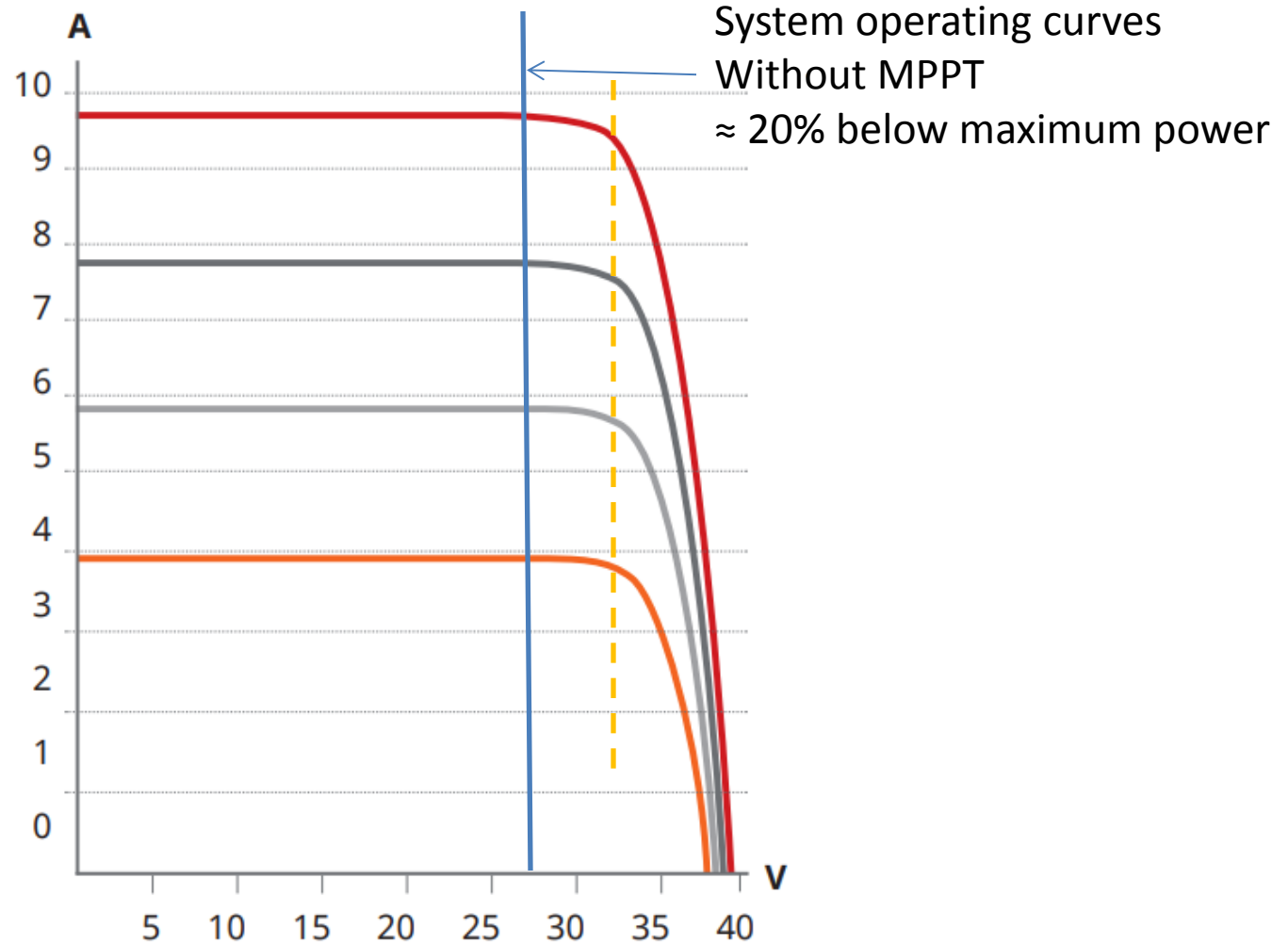

Example 1 (cont.)

Charge Controller is built within the inverter – equipped with MPPT

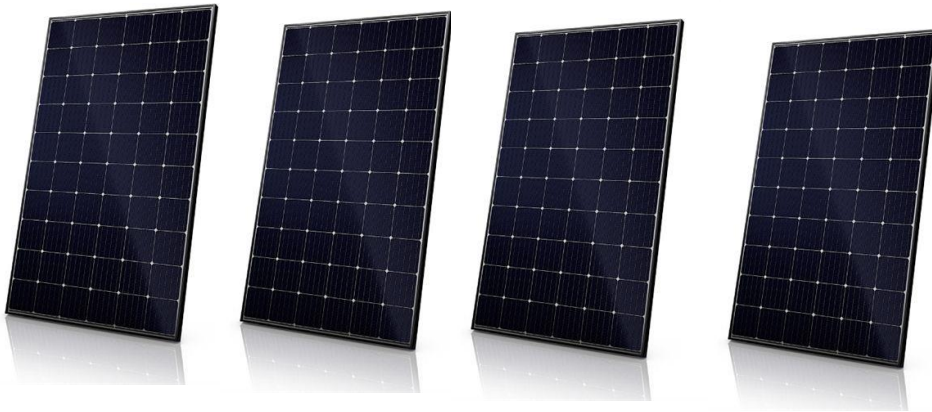

Example 1 (cont.)

- A PV– battery system sized to cover the worst month. Delivers more energy than is needed during the rest of the year.
- A smaller PV system that is based on annual PSH will require an excessively large storage system to carry excess from one month into a later month.

